

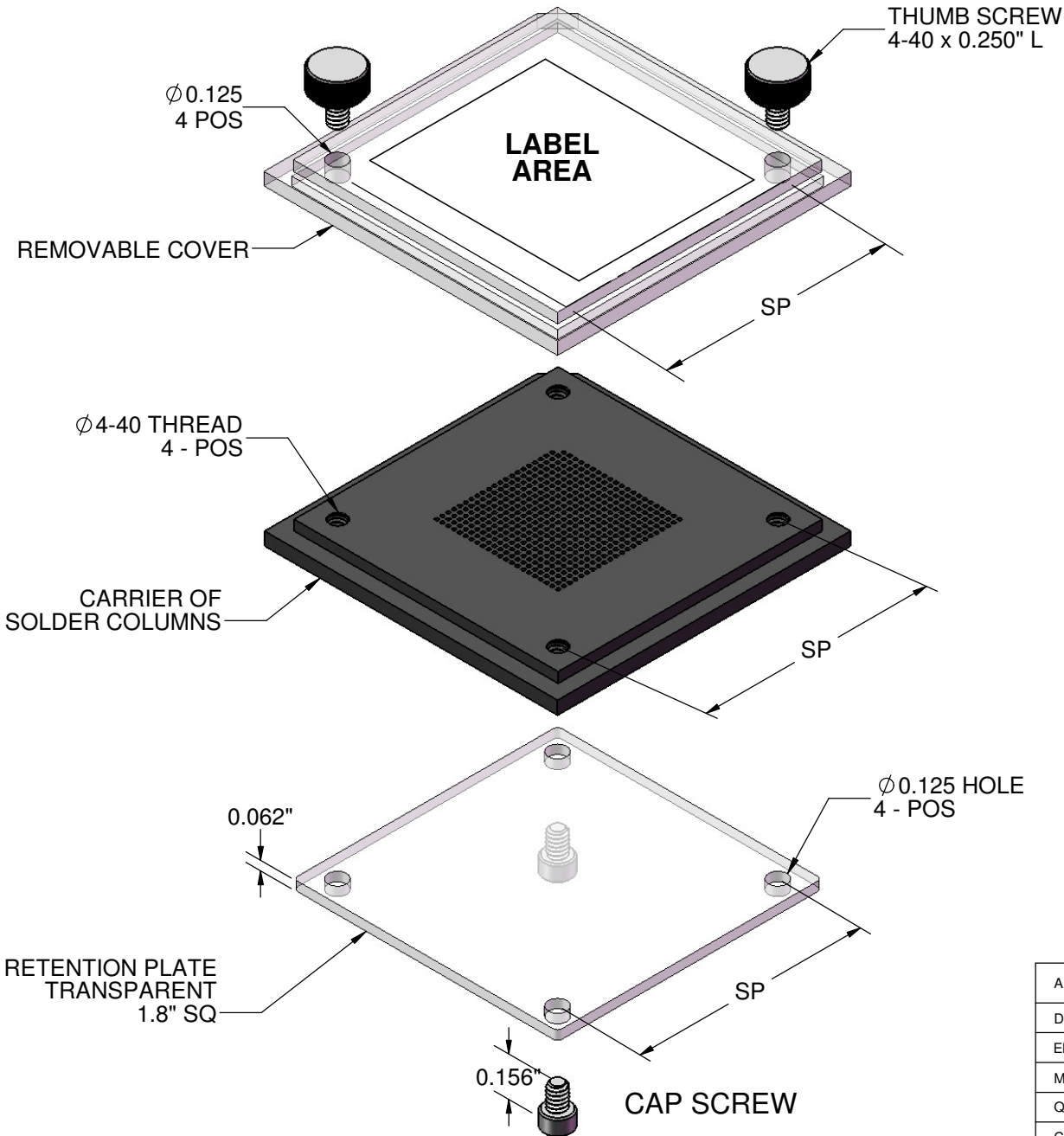

MANUAL FILL COLUMNS IN FLIP-PACK



SP	DP#	DESCRIPTION
1.5"	001040	TOP COVER
1.5"	001050	RETENTION PLATE
1.5"	704018	4-40 x .187" THUMBSCREW
1.5"	704033 704034	4-40 x .156" CAP SCREW 4-40 x .156" BUTTON HEAD
1.5"	704002 704000	3/32" HEX DRIVER 1/16" HEX DRIVER
1.65"	001046	TOP COVER
1.65"	001066	RETENTION PLATE
1.65"	705625	2-56 x 0.250" CAP SCREW
1.65"	705615	2-56 x .156" BUTTON HEAD
1.65"	704005 704003	5/64" HEX DRIVER 3/64 (0.05") HEX DRIVER
1.68"	001048	TOP COVER
1.68"	001068	RETENTION PLATE
1.68"	707225	1-72 x .250" CAP SCREW
1.68"	707216	1-72 x .156" BUTTON HEAD
1.68"	704000 700403	1/16 HEX DRIVER 3/64 (0.05") HEX DRIVER

U.S. PATENTS 9,108,262 and 9,629,259

APPROVALS	DATE					
DRAWN T. Au	4/22/2017					
ENG M. Hart	4/22/2017	TITLE MANUAL FILL FLIP-PACK				
MFG		SCALE 1.25:1		SIZE A	DRAWING NO. 001027	REV A
QA		DO NOT SCALE DRAWING			SHEET 1 OF 9	
CUST						
REVISED						

STEP 1 TEMPORARILY ATTACH COVER WITH CAP SCREWS

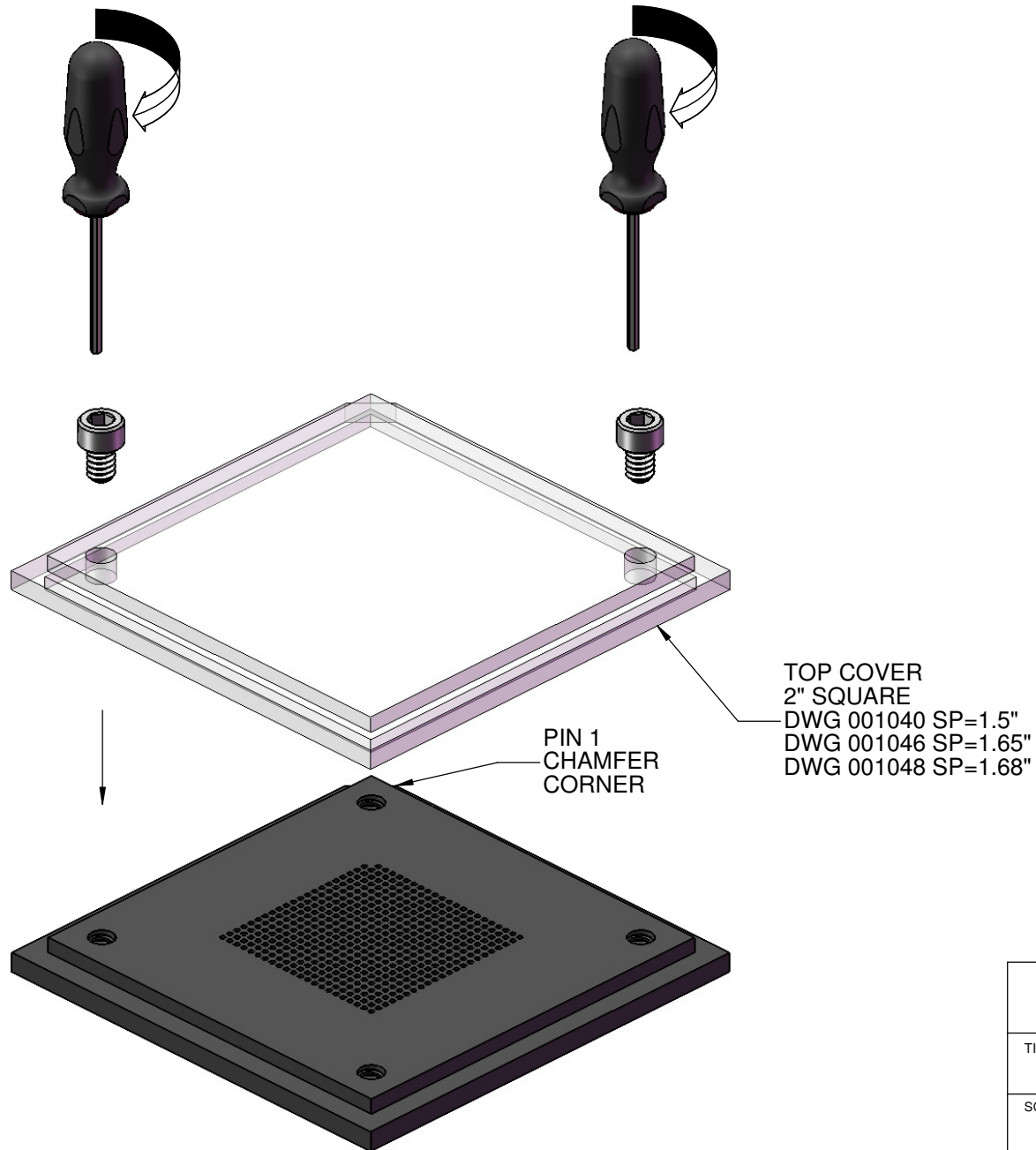

TopLine[®]

TITLE
MANUAL FILL FLIP-PACK

SCALE	SIZE	DRAWING NO.	REV
3:2	A	001027	A

DO NOT SCALE DRAWING

SHEET 2 OF 9

**STEP 2
FLIP OVER AND
PLACE IN THE UNIVERSAL
INSERTION TOOL FIXTURE**

**CARRIER
CAVITY SIDE
COUNTER SINK
FACE UP**

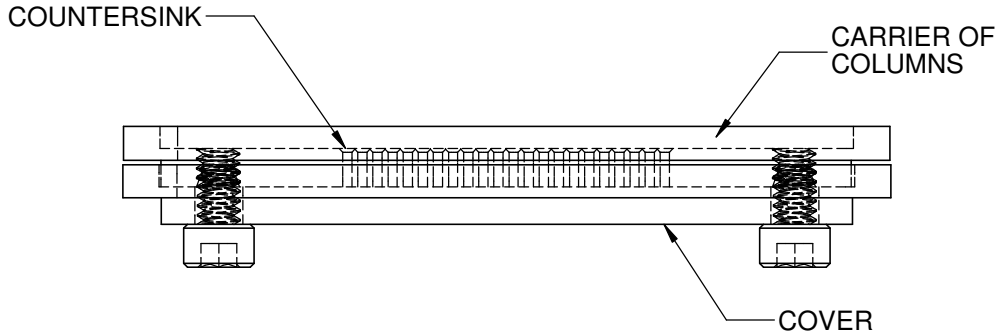
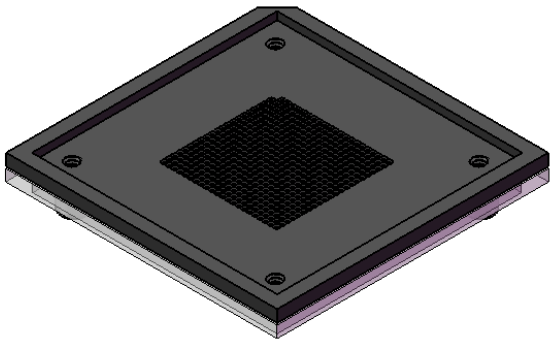

SIDE VIEW

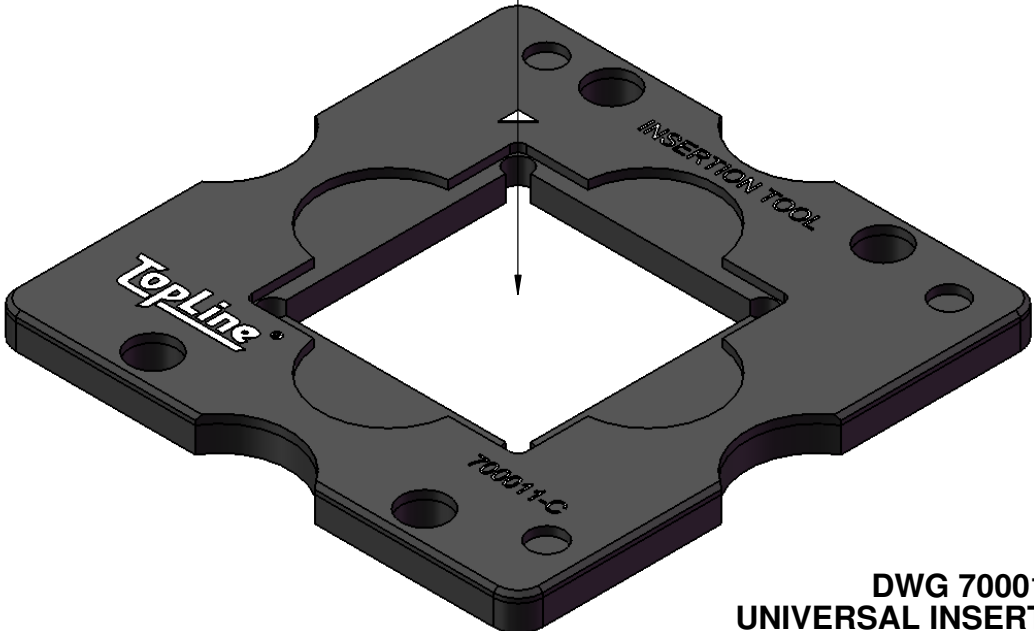

**DWG 70011
UNIVERSAL INSERTION TOOL**

TopLine®			
TITLE MANUAL FILL FLIP-PACK			
SCALE 1:1	SIZE A	DRAWING NO. 001027	REV A
DO NOT SCALE DRAWING			SHEET 3 OF 9

**STEP 3
MANUALLY FILL COLUMNS
FROM COUNTER SINK SIDE**

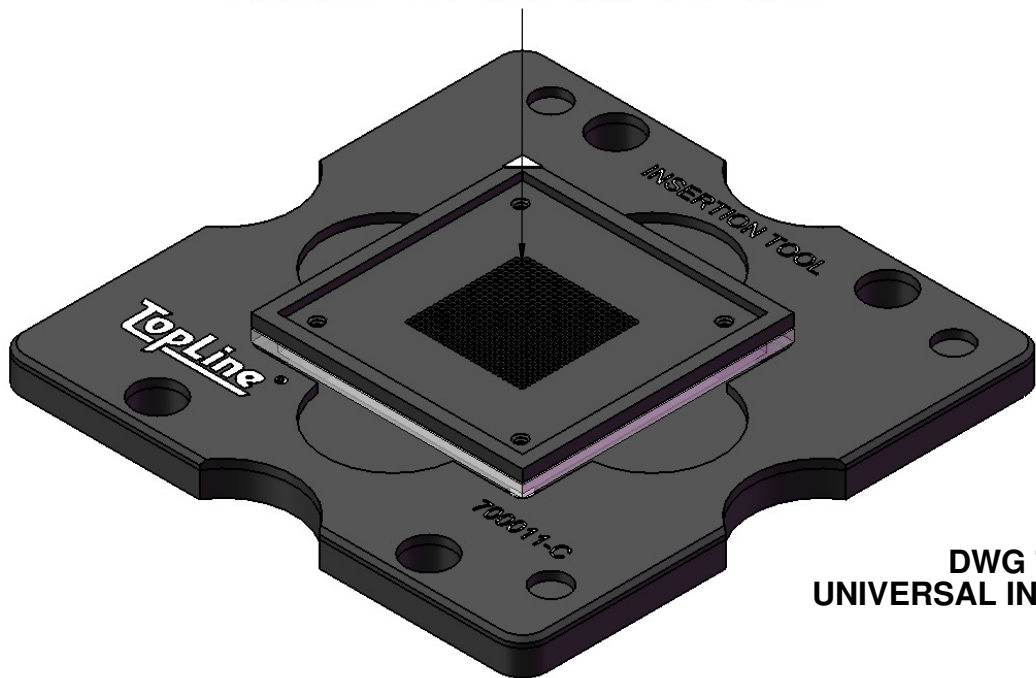
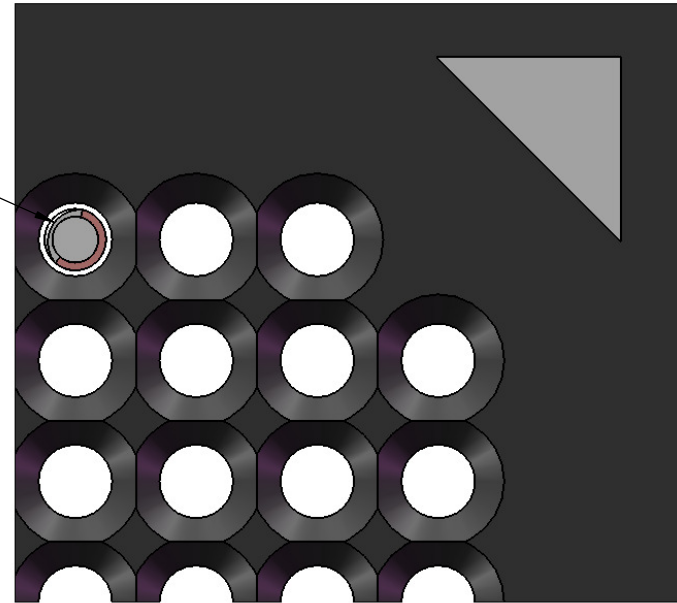
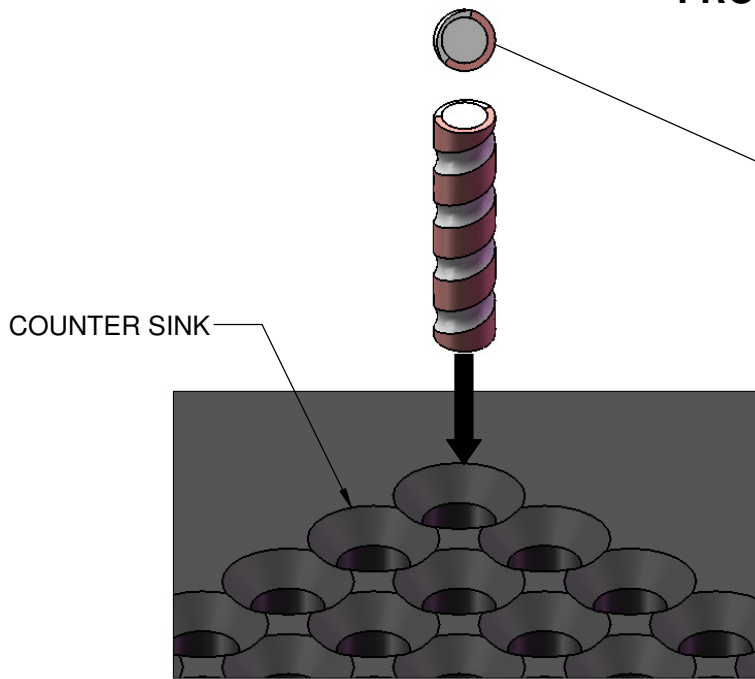

**DWG 700011
UNIVERSAL INSERTION TOOL**

TopLine®			
TITLE MANUAL FILL FLIP-PACK			
SCALE 16:1	SIZE A	DRAWING NO. 001027	REV A
DO NOT SCALE DRAWING			SHEET 4 OF 9

STEP 4 ATTACH RETENTION PLATE

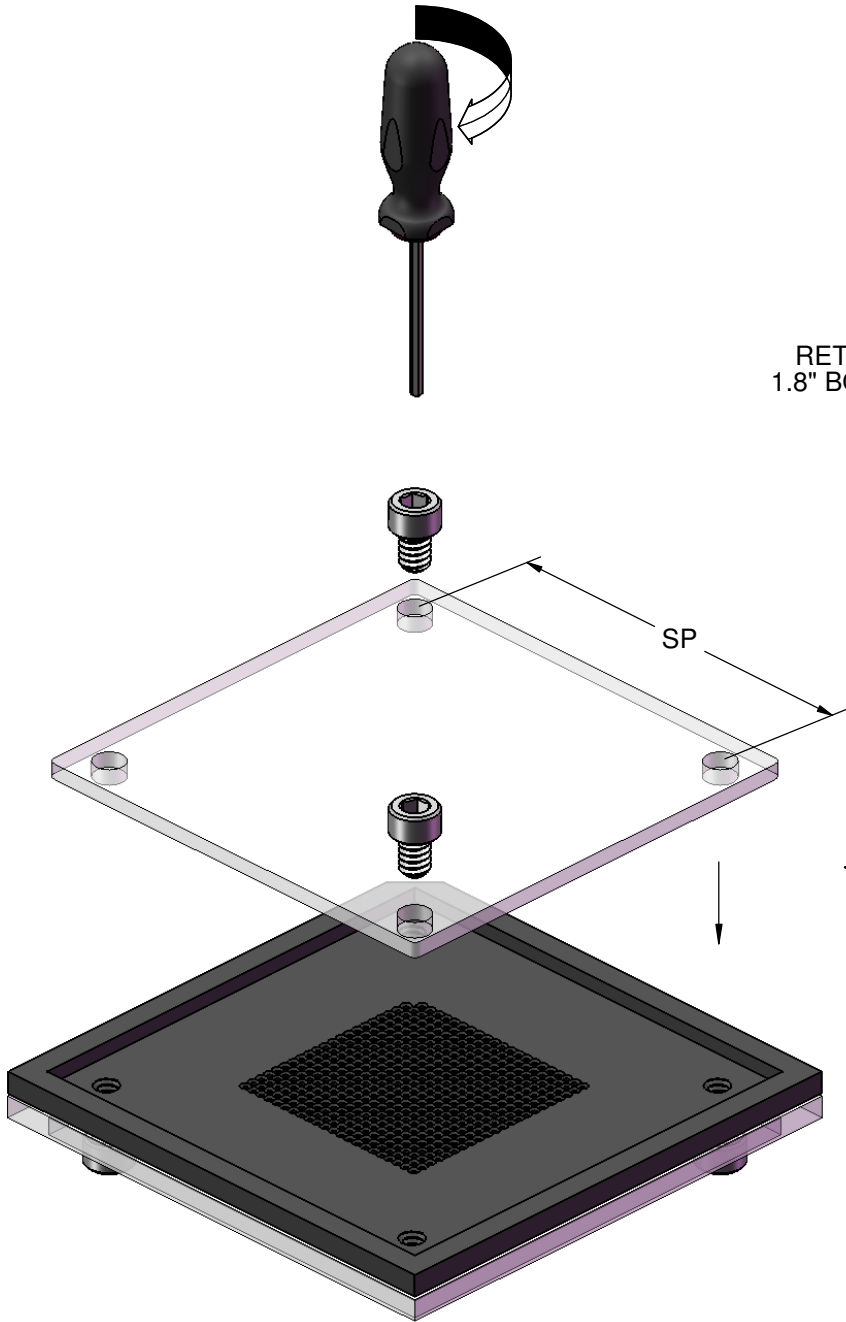

BOTTOM VIEW

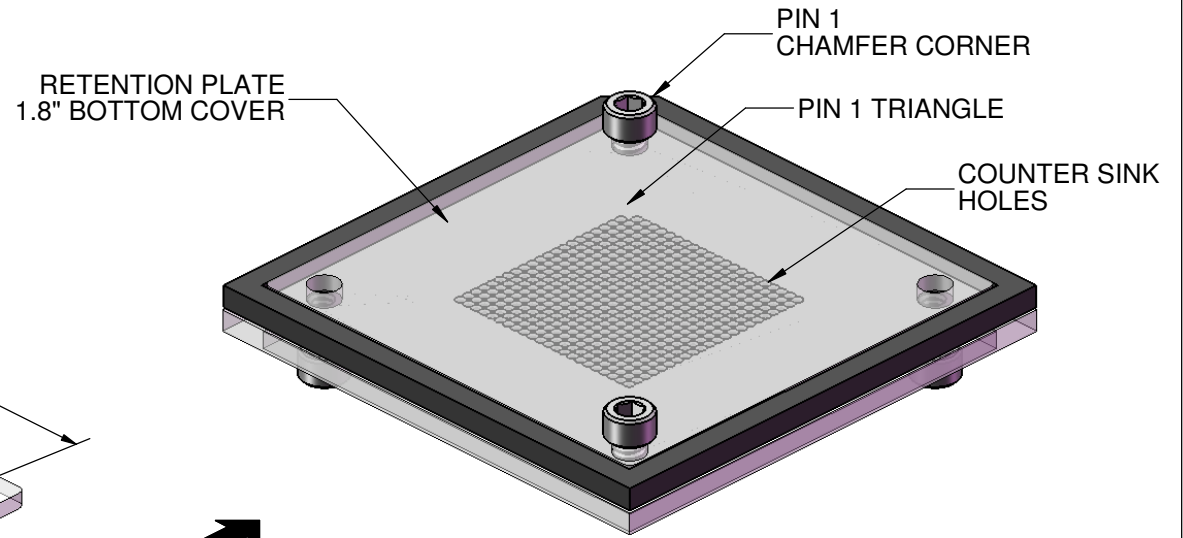

SP	DWG	SCREWS TOP COVER
1.5"	704033 704034	4-40 x .156" CAP SCREW 4-40 x .156" BUTTON HEAD
1.65"	705615	2-56 x .156" BUTTON HEAD
1.68"	707216	1-72 x .156" BUTTON HEAD

TopLine®			
TITLE MANUAL FILL FLIP-PACK			
SCALE 3:2	SIZE A	DRAWING NO. 001027	REV A
DO NOT SCALE DRAWING		SHEET 5 OF 9	

**STEP 5
REPLACE CAP SCREW WITH
THUMB SCREWS**

TOP VIEW

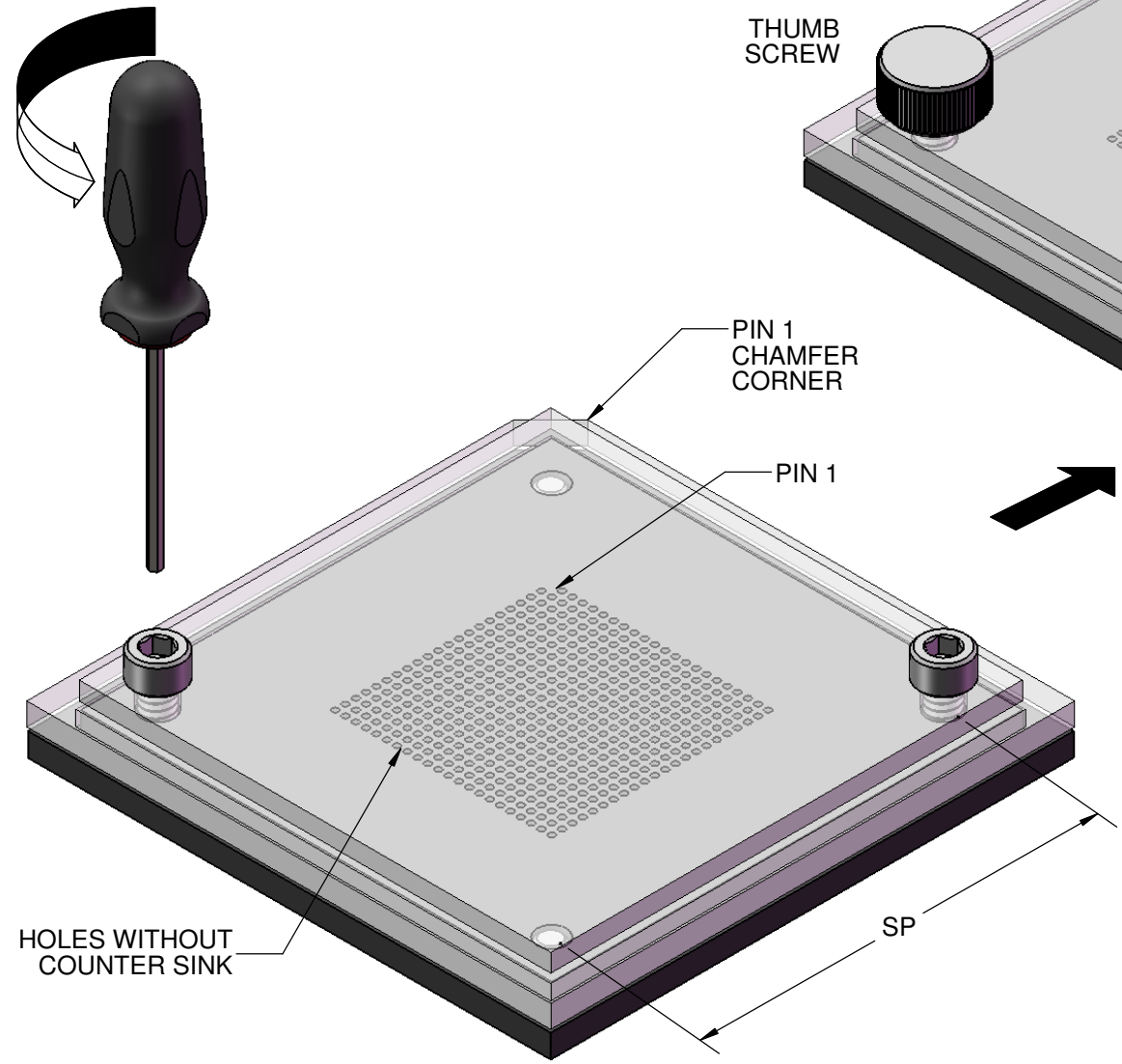
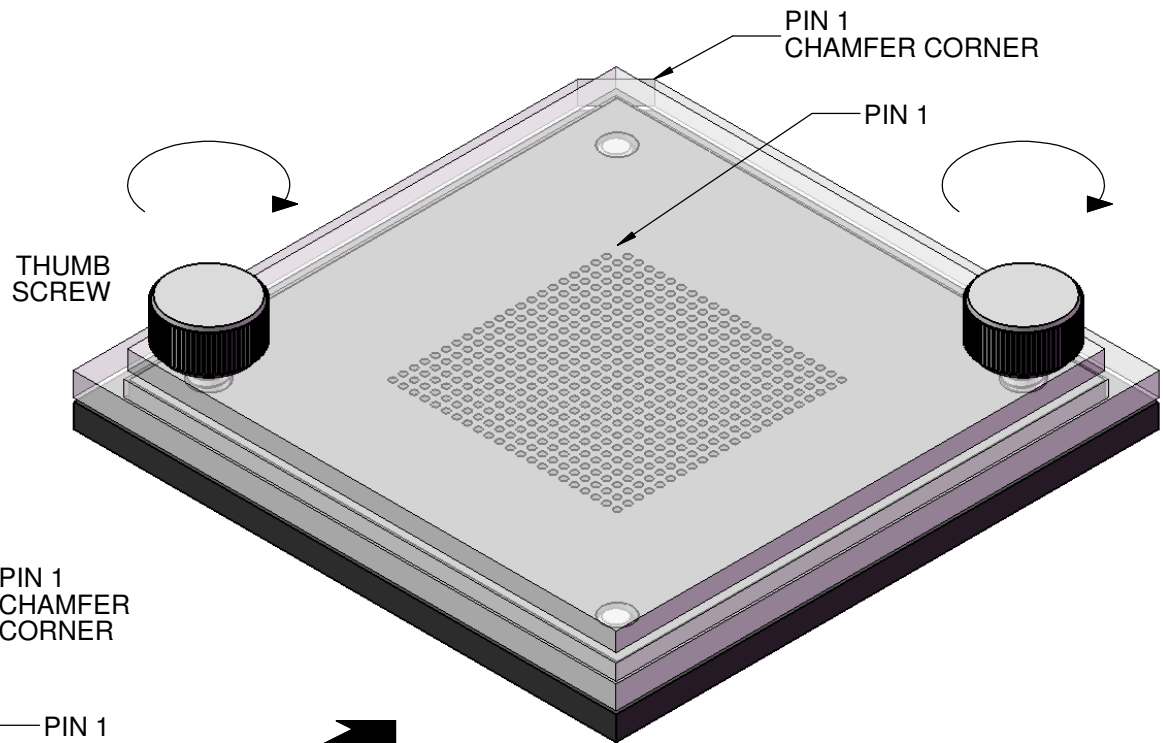

SP	DWG	SCREWS TOP COVER
1.5"	704018	4-40 x .187" THUMBSCREW
1.65"	705625	2-56 x 0.250" CAP SCREW
1.68"	707225	1-72 x .250" CAP SCREW

TopLine®

TITLE **MANUAL FILL FLIP-PACK**

SCALE 2:1	SIZE A	DRAWING NO. 001027	REV A
--------------	-----------	-----------------------	----------

DO NOT SCALE DRAWING SHEET 6 OF 9

STEP 6
PLACE 1.25 x 1.75
ID LABEL ON TOP COVER
(EXAMPLE)

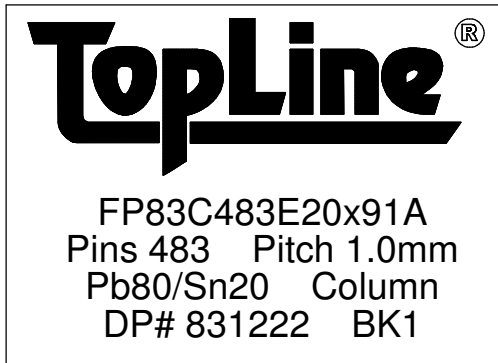

MODEL

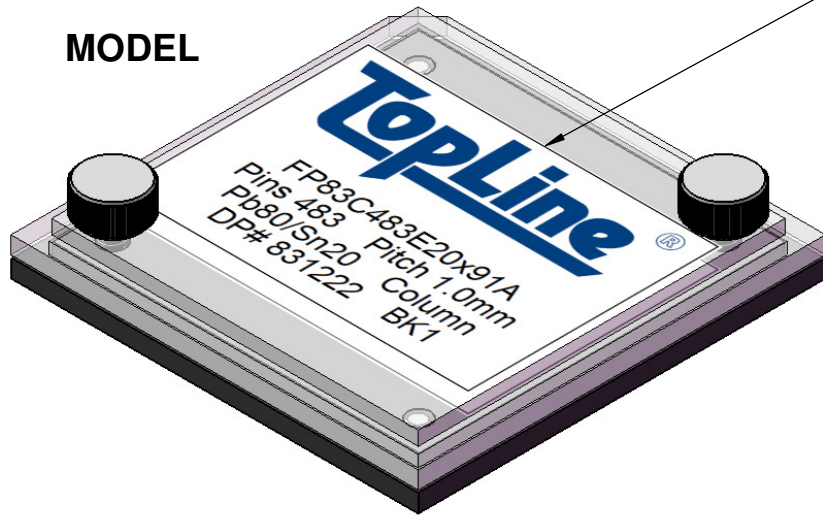

TopLine ®			
TITLE MANUAL FILL FLIP-PACK			
SCALE 3:2	SIZE A	DRAWING NO. 001027	REV A
DO NOT SCALE DRAWING		SHEET 7 OF 9	

STEP 7 PACK JEDEC TRAY

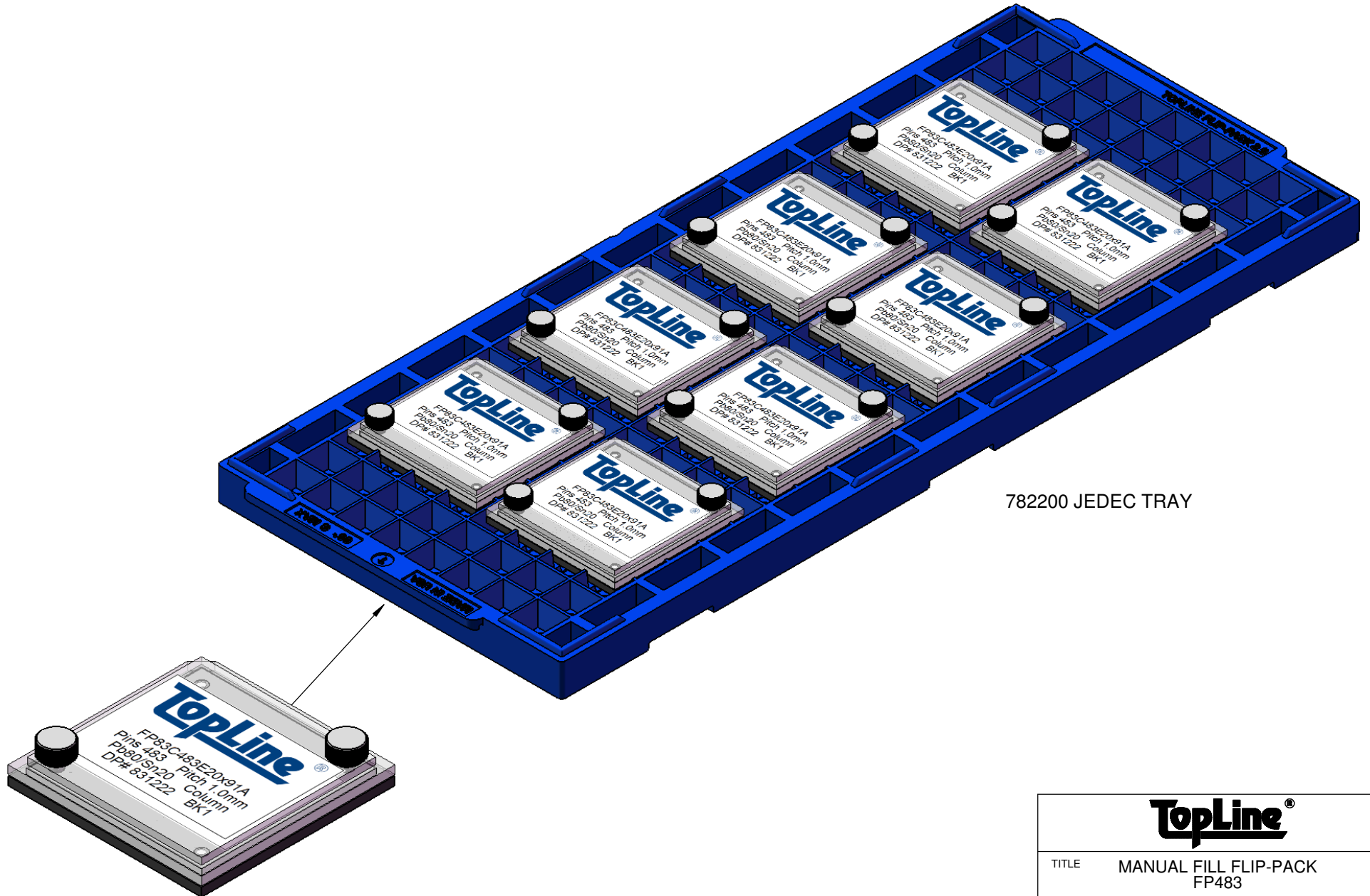

782200 JEDEC TRAY

TopLine®			
TITLE MANUAL FILL FLIP-PACK FP483			
SCALE	SIZE	DRAWING NO.	REV
2:3	A	001027	B
DO NOT SCALE DRAWING			SHEET 8 OF 9

