

5 GG9 A6 @M9 LD@C8 98 'J=K

: @D!D5 7 ? (F) GMGH9 A

I "G" D5 H9 BH' Bc"
- 2/\$, z& & UbX' - z & z& -

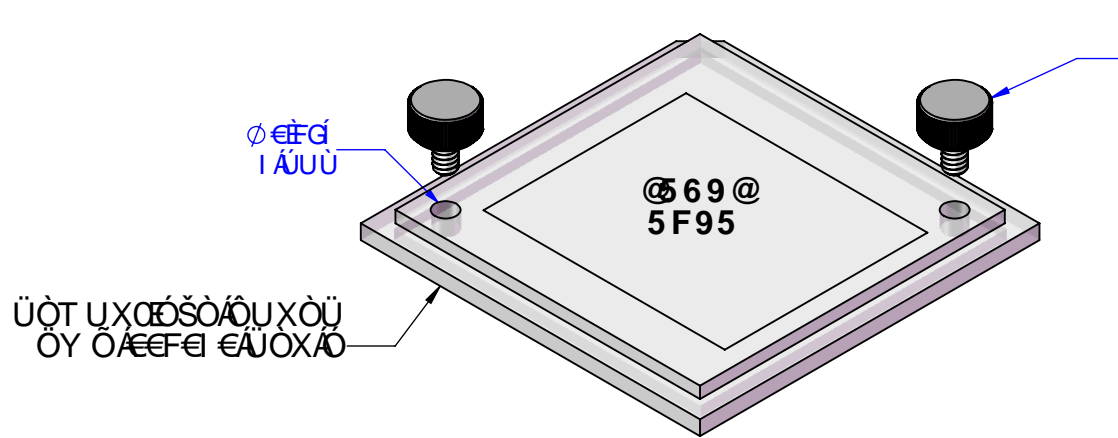

VPWT ÓÁÚÔÛÒÿ
I.È €Á/€FI I ÁS
ÖY ÓÁ €I €FI

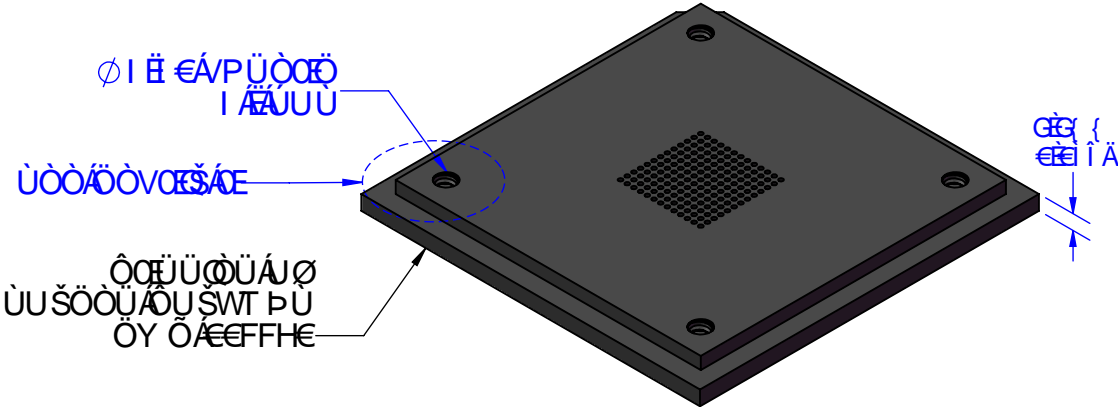
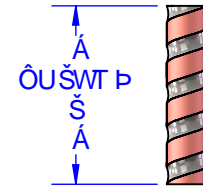

8 =A9BG-CB'H5 6 @			
<	@ A5L	K	8 K ;
I ÈG { €€I I Á	GÈ I { €€€Á	FÈ G { €€I GÁ	FG€G I

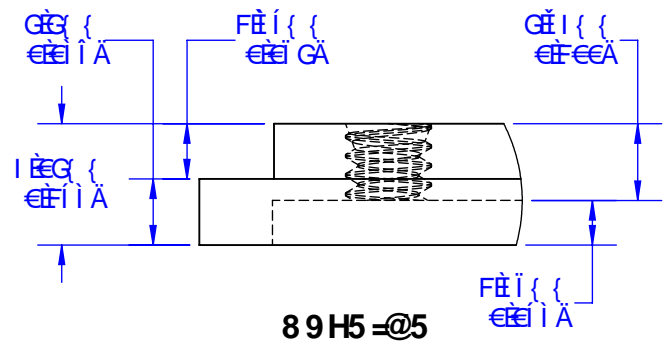
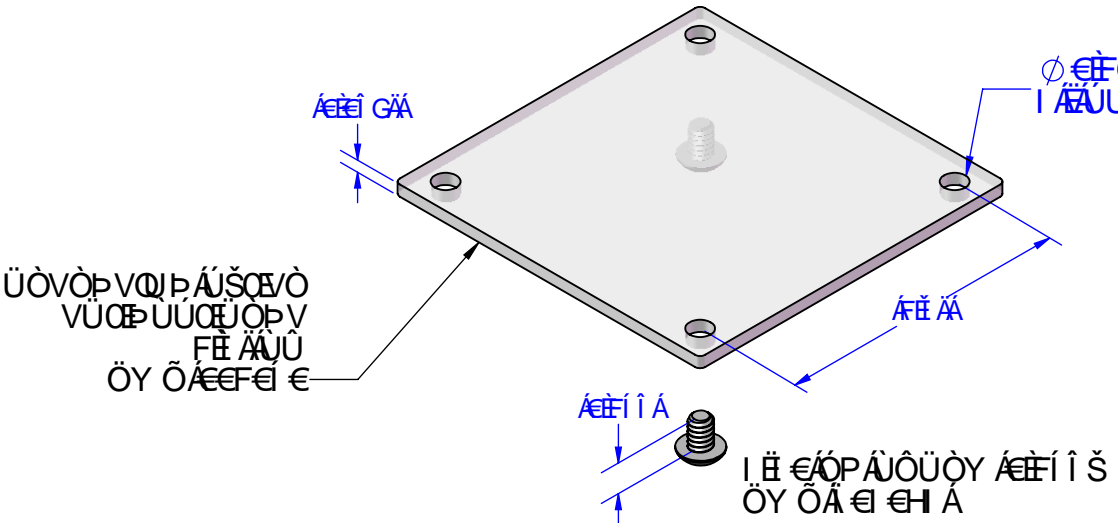

ÖÚÛÛXÓŠÛ	ÖC/V	TopLine®		
ÖÚCÿ P ÁÁÁ VÈE	FFB BBEFI			
ÖPÖ T ÈP æc	FFB BBEFI	VQŠÖ		
T Ø		ÖÚFI JQÁ ÖŠWÁJÓŠÁ		
ÚCE		ÚCŠÖ FÈG K€	ÚCÖ CE	ÖÚCÿ ÖÓPUE €€FFHE
ÖWUV				ÚOX CE
ÚOXÁÖÖ		ÖÚPUVÁÚÓCŠÖÖÚCÿ ÖÖ		ÚPÖÖVÁÚÖF€G



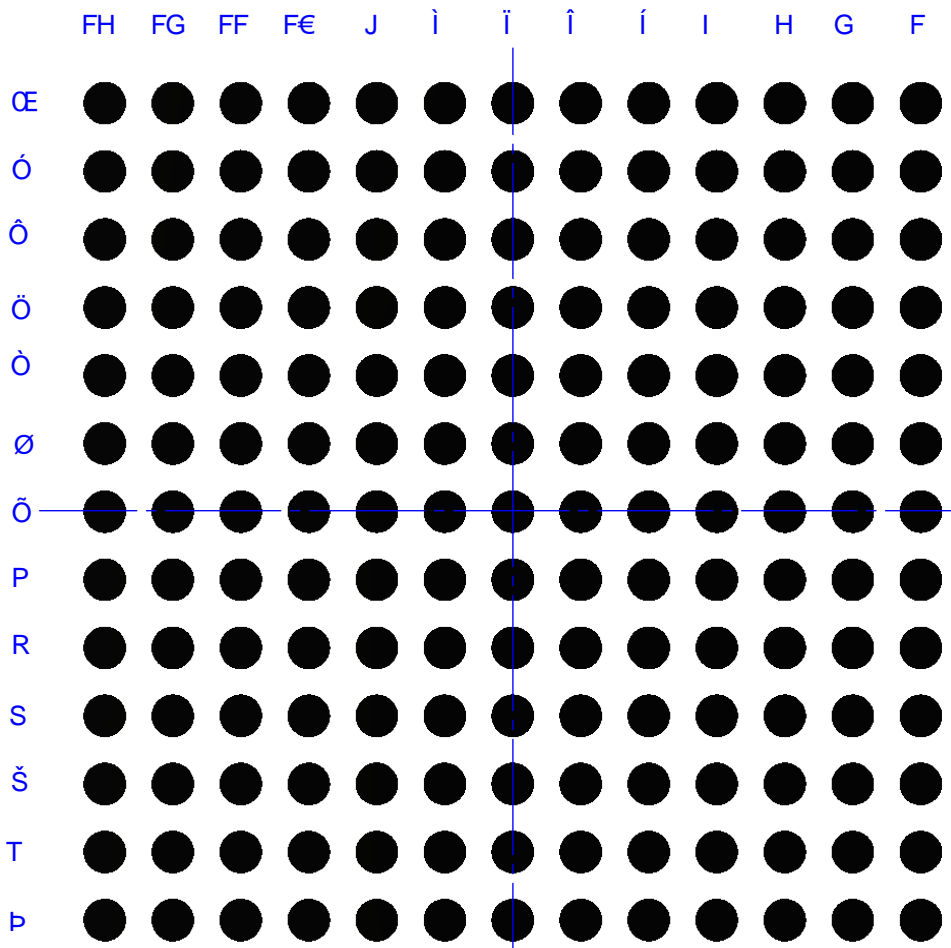

D5 FH'BI A69F 'H56 @

øšwëúœs [Ⓢ]	Úā•	Úā&@	T æææ	ÔŠWT P					Ò[]ç ÖY Ö	Ø ^å ÖY Ö
				Ø [^	Ô[]•d~ &ç[}	Ú æææ *	φ Öææ	Š^ } * @		
øújhôfí jògèçjfcè	fí j	fèè[{	fhýfh	úàjè	ô~ äüæà[}	ù) úà	œë f[{	gèf[{	œëffhè	jhffhè



6 CHCA

ÒYœT ÚŠÒÙÀÚØÁÔŠWT PÙ

øúì hò øújhò	øújèw	øúfí ú	øúfjò
			
Úàì èw) gèÁ Úàjèw) fè Ô~ äüœup	Úàjèw) fè ÚŠœP	T æ[èö[å ù] å* ù) úà	T æ[èö[å ù] å* Ô[åüææ

TopLine®			
vαsò		øúfí jçá øšwáúœsá	
úœsò PUPÒ	úœò œ	úœy œò&uè œëffhè	úœx œ
œu&uvúœsò&úœy œò			ùpòœv&úœf&g

G89

HCD'J=K

HCD'J=K

F H I J FF FH FI FI FJ GF GH G
G I I I FE FG FI FI FI OE GG G

φ εεεG
FÍ JÁUU

ÚΦΑ

φ εεεG
FÍ JÁUU

φ εεεG
FÍ JÁUU

ÔÔÕÖ
ÕÜÖÛPQÖ

Û^
ÖÖVÖSÁ

89H5=@9

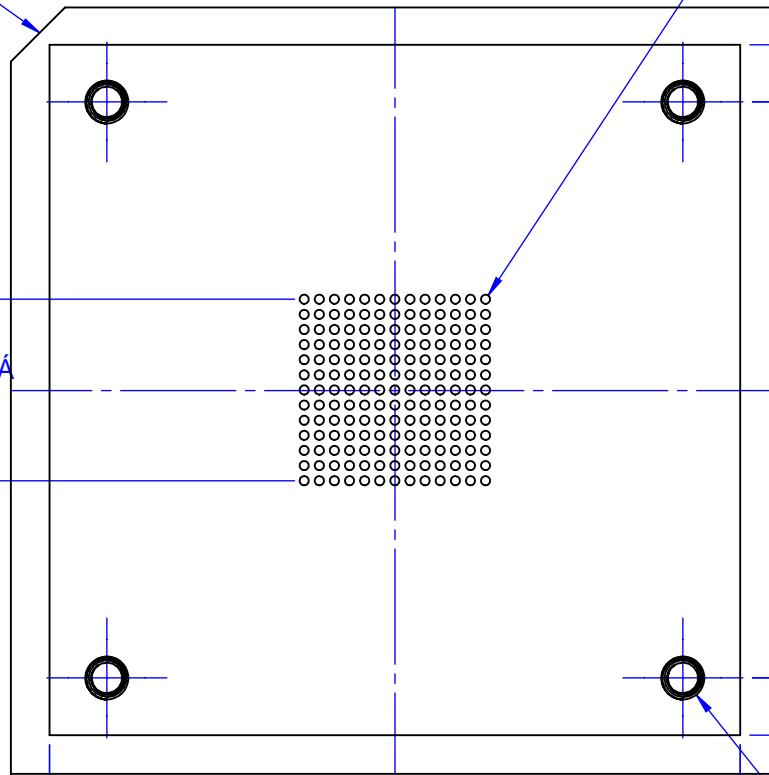
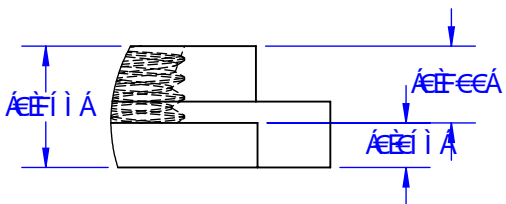

Ö
Ö
Ø
P
S
T
Ú
V
X
Y
ÿ
ÖÖ
ÖÖ

Áεεí Á

Áεεí Á

ÁεεεÁ

Áεεí Á

Á FÈJíá Á
[íεε{ { }

Á εεí Jjá Á
[GGÈH { }

Á εεí Jjá Á
[GGÈH { }

Á FÈJíá Á
[ííÈí{ { }

Á FÈJíá Á
[íεε{ { }

φ í È €
VPÜÖÖÖ
I ÈUU

PUÖÖÓPÖUV

ÚYT ÓUŠ	ÖÖF.ÖVÖÜ WPÜSÖ/ÖÖ VPÜW	ÖUWPVÖÜ UΦS	ÜVY
○	φ εεεG	È	FÍ J
⊕	VÖJÁεεí J	È	I
VPÜÖÖÖ	I È €	È	I
◎	È	φ εεε H	FÍ J
			VUVÖŠ H G

TopLine®

varšö

ÖUFÍ JÖÄ
ÖSÖJÁÖÖSÁ

ÚÖÖÖ	ÚÖÖ	ÖÜÖY ÖÖÖPUE	ÜÖX
GF	ÖE	€€FFHEÁ	ÖE

ÖÜÖUVÁÜÖÖSÖÖÜÖY ÖÖ

ÜPÖÖVÁHÜÖFEG

β [c • K W , I • • Á U c @ ! , ä ^ Á] ^ & ä a ð
Á F D T Ö V Ö Ü Ö S K Ö S Ö S Á U S Ö U V Ö Ö Ö Ö P Ö W Ö V Q Ö È
Á Ö Ö Q Ö P Ü Ö P U Á Ö Ö Ö Ö Ö U Á T T È

8 9 H5 = @ 8
 K # K ' 7 C J 9 F ' D @ H 9

VPWT ÓÀÛÖÙÒÛ

ÔÛXÒÛ

ÔÆÛÛÒÛ

ÛÒÙÒÙ VÙÛÛ
 ÛSÆÛ/Ó

ÛÖÙÒÛ

ÀËËËÀ
 ÀËËË Ì Á

AC89@

ÛÒÙÒÙ VÙÛÛ
 ÛSÆÛ/Ó

ÛÖÙÒÛ

ÛÒÙÒÙ VÙÛÛ
 ÛSÆÛ/Ó

ÀËËË Á

ØÆSÁÙ VÙ ÆÛÆÛÛÙÒ

ØÙÌ HÒ

ØÙHÒ

ØÙJHW

ØÙËË Û

ØÙËË Ò

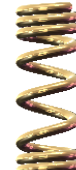
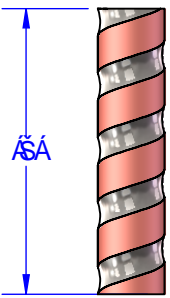

ÙÀÌ ÆÛÛ ÆË
 Ó ÆÛÙÙÛÛ

ÙÀÌ ÆÛÛ ÆË
 Ó ÆÛÙÙÛÛ

ÙÀÌ ÆÛÛ ÆË
 ÛSÆÛ

T æË ÆË ÆË
 ÛË Ì ÆË
 ÛË ÛÀ

T æË ÆË ÆË
 ÛË Ì ÆË
 ÓË Ì ÆË ÆË

TopLine®

VÙSÒ			
ØÙËË JÙÆ ØSÙÀÙÙSÁ			
ÙÙSÒ Ë Æ	ÙÙÒ Æ	ÙÙÆÛ ØÙÆÛË ÆËËËË	ÙÙX Æ
ØÙÆÛ VÙÀÙÙSÒ ØÙÆÛ ØÙ			ÙÙÙÙVÁ ÆÛÆË

7CJ9F \$\$\$ (\$'F9J'6

: @D'D57? AC89@

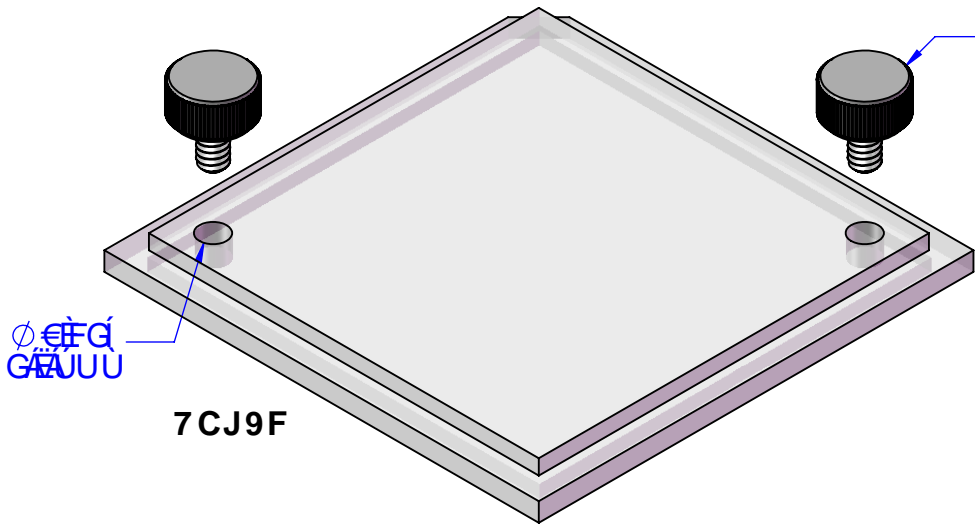

VPWT ÓÀÙÒÛÒÛ
I È ÇÁÀÈÍÍÁΣ
ΛΛΛΛΓΕΥΥ

∅ ΕΓΓ
ΓΕΥΥ

7CJ9F

6CHCA

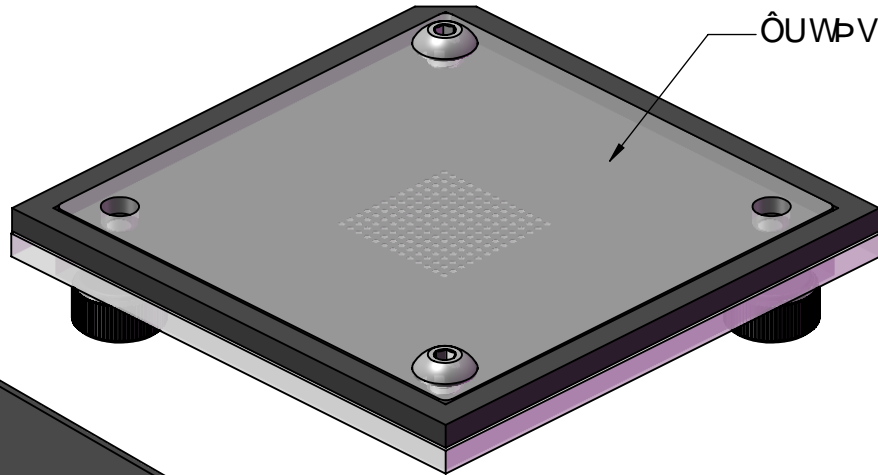

ÓΥΨΒΟΥÛÀÙΣ

HCD

ΨΥΨΒΟΥÛÀÙΣ

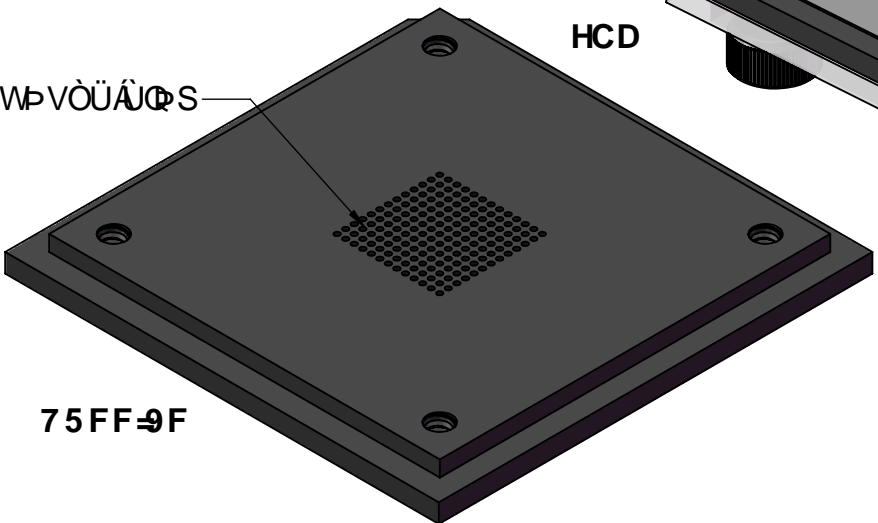

75FF-9F

ΛΛΛΛÙÒÛÒÛ
I È ÇÁÀÈÍÍÁΣ
ΛΛΛΛΓΕΥΥ

TopLine®			
Vαρσό		ΘΥΓΙ JQZ ØΣΩΑΙJQZΣΑ	
Υαρό	Υαρό	ΌΥαΥ ρΘΑΥÈ	ÙòX
GF	CE	ΕΕFFHE	CE
ΌΥΑΥVÀÙQZΣQZÙQZ ρΘ			ÙΡQZVÀ ÆØFG

F9H9BHCB'6 CHHCA'D@H9'8K ; '\$%\$) \$

G89 J9K

HCD'J9K

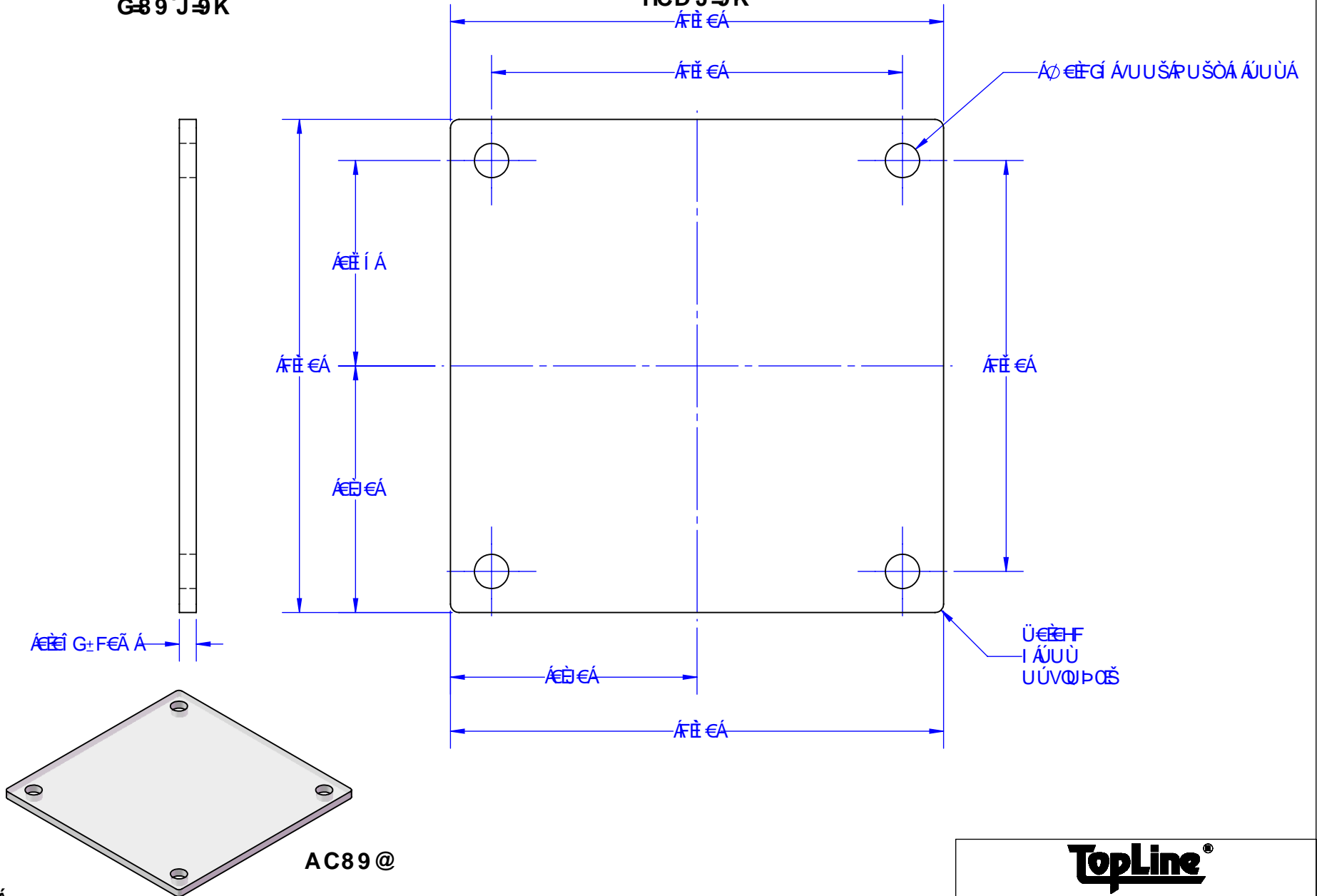

AC89@

ΠΥΝΟΥΑ
 ΑΕΩQ OP ÙQ ΠΥΑP ÔP ÒUÁΠP ŠÒUÙAJVPÒUY QIÒAJVCE/ÒÈ
 ΑΓΑT CE/ΟΥQISÁOSOCUÁUÔÈHΕAJU SYÔCÛOU ΠCE/ÓAQ ÒUÓÁUQZÒÈ
 ΑΕAJVCE/ÓÁQ ÒUQV/QÓÁF dFÉ È

TopLine®			
VQCSO		ÜÒYQΠVQΠP USQV/O	
UQCSO	UQO	ÜQV QÔÁUÈ	ÜQX
GF	CE	€FÉI €	CE
ÖUÁUVAÚQCSOÖUQV QÔ			ÛPÖQVÁ AJQAFG

: @D!D5 7 ?^(E) D5 FH'BI A 6 9 F-B; 'GMGH9 A

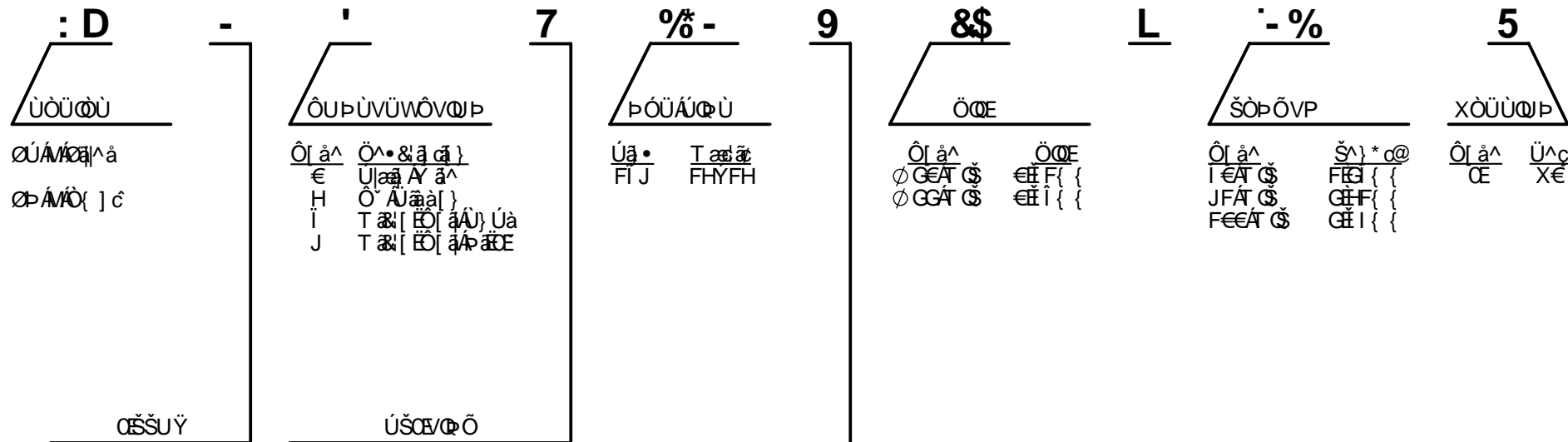

Technical codes and symbols for the bolt types shown in the diagram above.

9L5 AD@G'C: '7C@ ABG

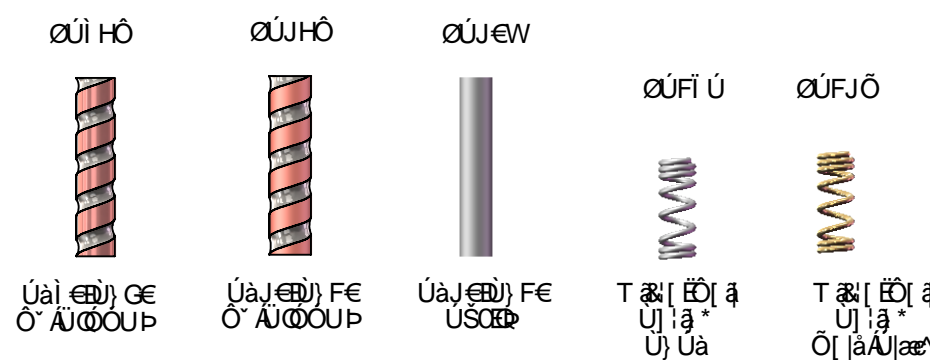

TopLine[®]			
νασό	Ø1 Fì JQÁ ØSÓUÁΩSÁ		
ύασό	ύαó	öüèè øðøUè	ύòx
FèF	èE	èèFFHè	èE
øøèU VVúòασóøðUèè øò			ÚPÒÖVÁ ÚUèèFG

PUVOAFUUI HEUUEa a AUUHAÜOUWÜOÜAÜQ T OÖAU/ÖPÜPÖÖSÖPÖVPÈ
 PUVOAGUÜSWT Pèè { AUUÖOÄÜQ T OÖAU/èè { èèVÖUèèVÖÖPT ÖP VÈ

: @D!D57? 8F5K-B; 'BI A69F-B; 'GMGH9A

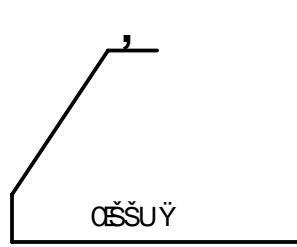

Ô| á^ Ö^•&ã á }
 €€ Ö| } c
 F T &| [É| á
 i Úà| [É| } GE
 J ÚàJ [É| } FE
 i Ú| i [É| } Fí

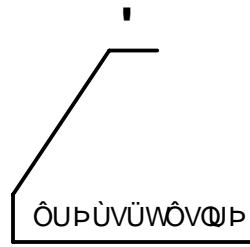

Ô| á^ Ö^•&ã á }
 € Ú|ã Á á^
 H Ö^ ÁJã| }
 i T &| [É| áU } Úà
 J T &| [É| á Þã

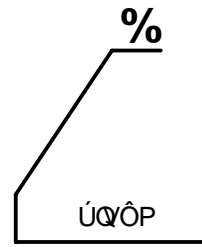

Ô| á^ Úã@
 F FE{

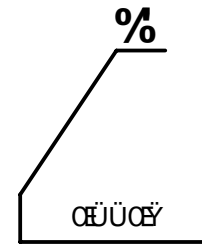

Ô| á^ Tãã
 FH FHYFH

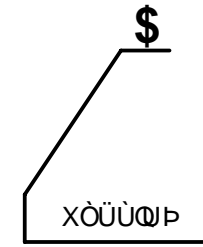

Ô| á^ Ô| | { }
 € GEJFAE| FA| G| F| { D
 F GE| FE| GE| FA| GE| | { D

9L5AD@G'C: '7C@ ABG

øùì Hò



Úà| [É| } GE
 Ô^ ÁJQOUP

øùJ Hò



ÚàJ [É| } FE
 Ô^ ÁJQOUP

øùJ eW



ÚàJ [É| } FE
 ÚSOKP

øúFì Ú



T &| [É| á
 Ú| |ã*
 Ú| Úà

øúFJ Ò



T &| [É| á
 Ú| |ã*
 Ô| |ãÚ|ã^

TopLine®

vαsò				øúFì JQÁ øSΩÁÚQESÁ			
úóαsò FEF		úαò CE	öüαÿ αòãUÉ €EFFHE		úòx CE		
öUãUVúóαsòöüαÿ αò						ÚPÖÖVÁÍÚQFG	

<5F8K5F9
 D@GH7?BI F@8<958'H<I A6'G7F9K

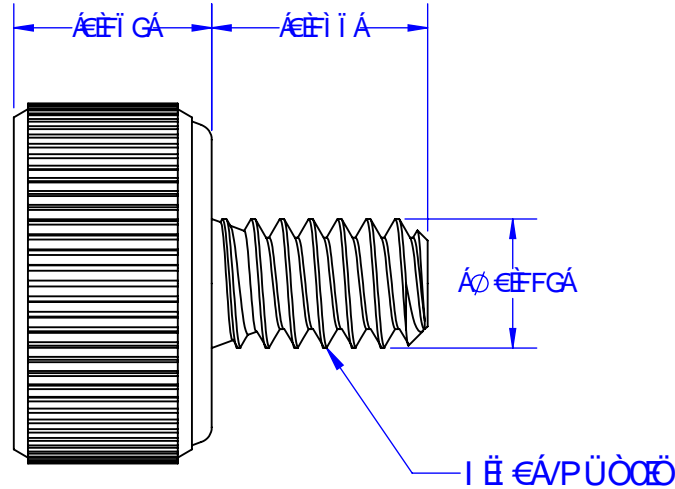
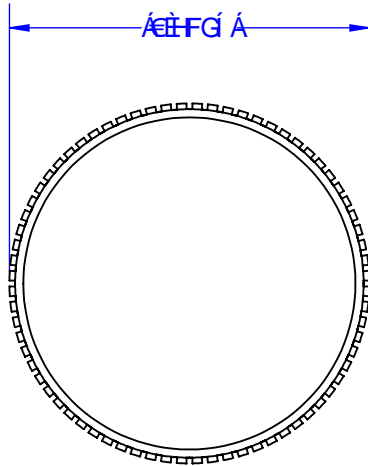

AC89@G

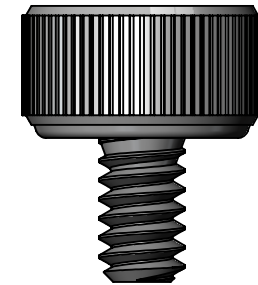
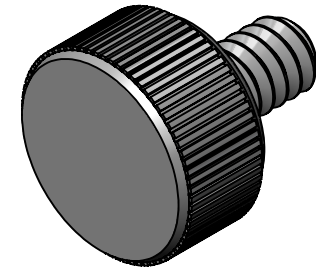

ΒΥΝΟΥΚ
 ΕΛΕΓΧΟΝΤΕΣ ΤΗΝ ΠΟΙΟΤΗΤΑ ΤΩΝ ΠΡΟΪΟΝΤΩΝ ΚΑΙ ΤΗΝ ΑΣΦΑΛΕΙΑ ΤΗΣ ΕΞΕΛΙΞΗΣ ΤΩΝ ΕΡΓΩΝ
 ΕΝΔΕΙΧΝΟΝΤΕΣ ΤΗΝ ΑΝΕΞΕΛΙΞΤΕΛΗΤΗΤΑ ΤΩΝ ΠΡΟΪΟΝΤΩΝ ΚΑΙ ΤΗΝ ΑΣΦΑΛΕΙΑ ΤΗΣ ΕΞΕΛΙΞΗΣ ΤΩΝ ΕΡΓΩΝ
 ΚΑΙ ΤΗΝ ΑΝΕΞΕΛΙΞΤΕΛΗΤΗΤΑ ΤΩΝ ΠΡΟΪΟΝΤΩΝ ΚΑΙ ΤΗΝ ΑΣΦΑΛΕΙΑ ΤΗΣ ΕΞΕΛΙΞΗΣ ΤΩΝ ΕΡΓΩΝ

8F-@H56@						
ΠΟΣΟΣΤΟ	ΒΥΝΟΥΚ	ΤΕΥΧΙΟ	ΥΠΟΛΟΓΙΣΜΟΣ	ΟΣΤΙΝ	ΣΥΝΟΛΟ	ΟΥΚ
ΟΣΟΣΤΟ	I È €	ΕΓΓΑ	ΕΓΓΑ	ΕΓΓΑ	ΕΓΓΑ	I È €

TopLine®			
ΠΡΟΪΟΝΤΑ ΑΝΕΞΕΛΙΞΤΕΛΗΤΗΤΑ ΚΑΙ ΑΣΦΑΛΕΙΑ ΤΗΣ ΕΞΕΛΙΞΗΣ ΤΩΝ ΕΡΓΩΝ			
ΥΠΟΛΟΓΙΣΜΟΣ	ΥΠΟΛΟΓΙΣΜΟΣ	ΥΠΟΛΟΓΙΣΜΟΣ	ΥΠΟΛΟΓΙΣΜΟΣ
I È €	€	I È €	€
ΥΠΟΛΟΓΙΣΜΟΣ			ΥΠΟΛΟΓΙΣΜΟΣ

<5F8K5F9
75D'G7F9K

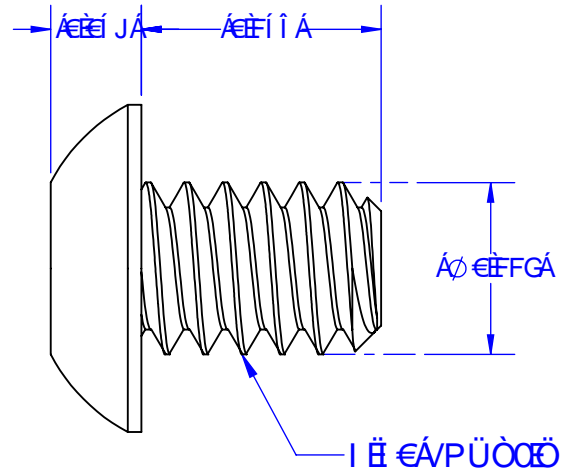
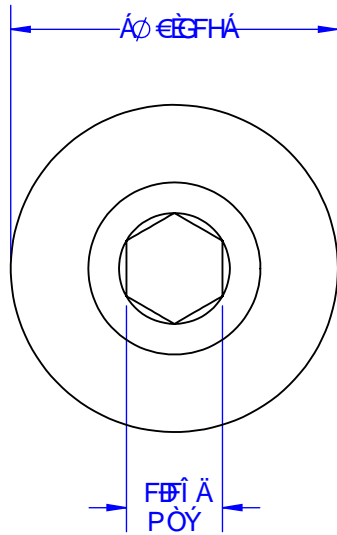

AC89 @

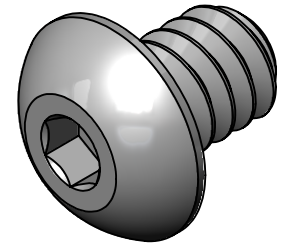

ΠΥΛΟΥΚΑΤΑ ΣΟΥΛΑ ΠΡΟΥΥ ΤΩΑΥΟΟΘΩΘ
 ΕΑΤ ΕΥΟΥΟΕΚΑΥΟΟΑ/ΟΟΣΟΕ
 ΗΟΥΣΥΗΚΑΥΟΟΑ/ΟΟΣΟΕ

8 F-@H5 6 @						
Τ ΟΕ/ΟΥΟΕΣ	ΟΥΣΥ	VPÜOÖ	ÔŠ/PUSÔ/AAAA OÖE	VOË/PUSÔ/AAAA OÖE	Š	ÖY Ö
ÙVÖPŠÖÙÙ	ÙVÖPŠÖÙÙ	I Ë €	€FG	€è J	€Fí î	ï € €H

ναςò ÓΜVUΠ/ΡΟΟΑΥΟΥΥ I Ë €ΑΡÜOÖ			
ÚOCSO ì K	ÚOZ CE	ÖÜAY @ÖÅUE ï € €H	ÚOX CE
ÖUÅUVÁÚOCSOÖÜAY @Ö			ÜPÖÖV/FFÁUÖFG

ΥΠΟΥΧΟΛΟΓΟΥ
ΠΟΥΛΕΙ

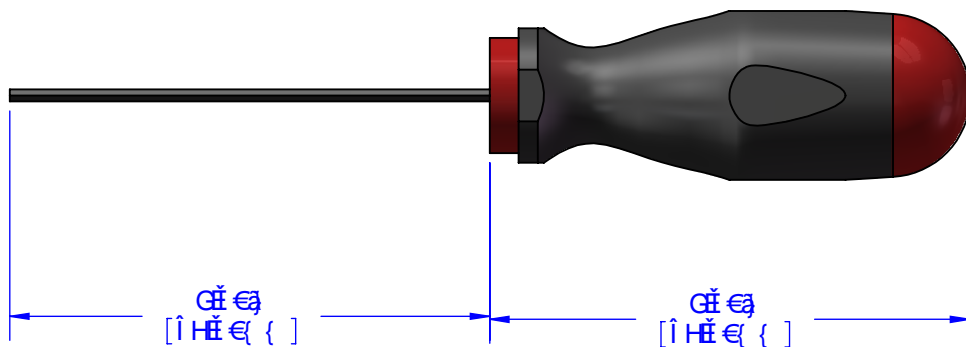
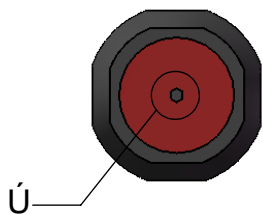

αἴμα
[ϊή€{]

αἴμα
[ϊή€{]

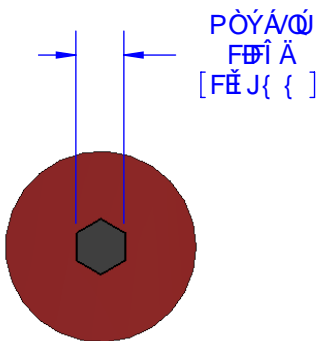

ΠΟΥΛΟ
ΠΟΥΛΕΙ
[FĚJ{]

ΟΥΟΕ ΨΟΑΟΥΟΥ
ΠΟΥΛΕΙ Α
ΥΟΟΟΑΜΑΚ

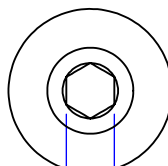

ΠΟΥΛΕΙ
ΠΟΥ

ΟΥΟΟΑ
ΥΟΟΟΑΜΑΚ

ΠΟΥΟΚΑΠ ΣΟΥΑΥΠΟΥΥ ΟΑΥΟΟΟΠΟΠΕ
ΑΡΔΟΓ ΟΠΟΥΠΟΥΚ ΠΑΤ Τ Ε

αἴμα	ΟΥΟ	<p>TopLine[®]</p> <p>ΥΠΟΥΧΟΛΟΓΟΥ ΠΟΥΛΕΙ</p>			
ΟΥΟΥ ΠΑΑ	ΪΠΓΒΕΠ				
ΟΠΟΑΑΑΑΑ ΠΑΑ	ΪΠΓΒΕΠ	ΥΟΟΑ	ΥΟΟ	ΟΥΟ ΠΟΑΠΕ	ΥΟΧ
ΤΛΟ		ΑΑΑ			
ΥΟΕ		ΥΟΟΑ	ΥΟΟ	ΟΥΟ ΠΟΑΠΕ	ΥΟΧ
ΟΥΟΥ		ΑΑΑΑΑΑ	Ε	ΪΕΕΕ	Ε
ΥΟΧΑΟΟ		ΟΥΑΥΑΥΟΟΟΟΥΟΠΟ			ΥΠΟΝΑΓ ΟΑΑΓ