

6 CB8-B; 'D58 G

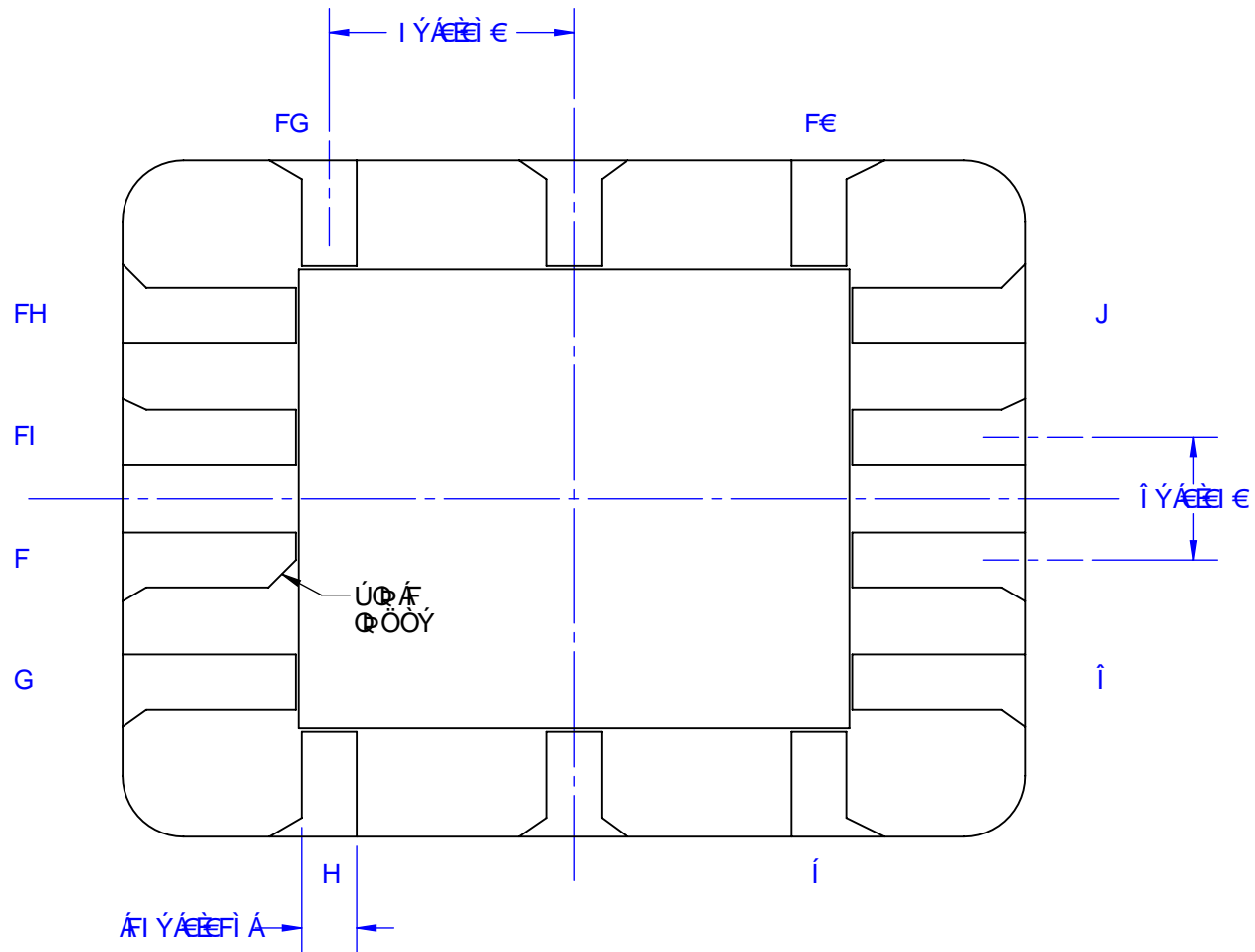

000000
 000000
 000000

D5 FH'BI A69F 'H56 @		
D5 FH'BI A69F	8 → 'D58	8 K ;
000000	0000	FI HI J

TopLine®			
000000			
000000	0000	00000000	0000
0000	0000	000000	0000
00000000000000			00000000

AC89 @G

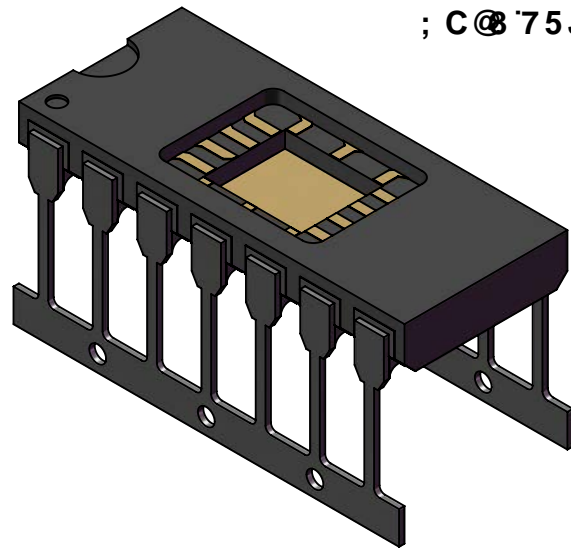

; C @ 75 J = M

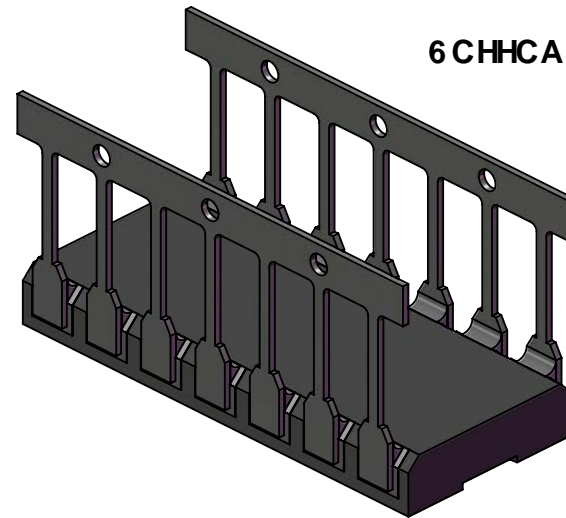

6 CHCA J = K

D5 FH'BI A69F 'H56 @		
D5 FH'BI A69F	8 → D58	8 K ;
ÔÔÛÔÛFÌ ØÈÛÖÈØ	ÔÛSÖ	FÌ HÌ J

TopLine®			
varšò ÔÔÛÔÛFÌ ØÈÛÖÈØ ÔÛAÛÖAÈ { { A'A ÈÌ { {			
Ûöæšò ÍK	Ûæò CE	ÛÛæÛ ØÖAÛÈ FÌ HÌ J	Ûòx CE
ØÛAÛVÁÛöæšòAÛÛæÛ ØÖ			ÛPÖÖNÁAÛZÁH