

BOTTOM VIEW

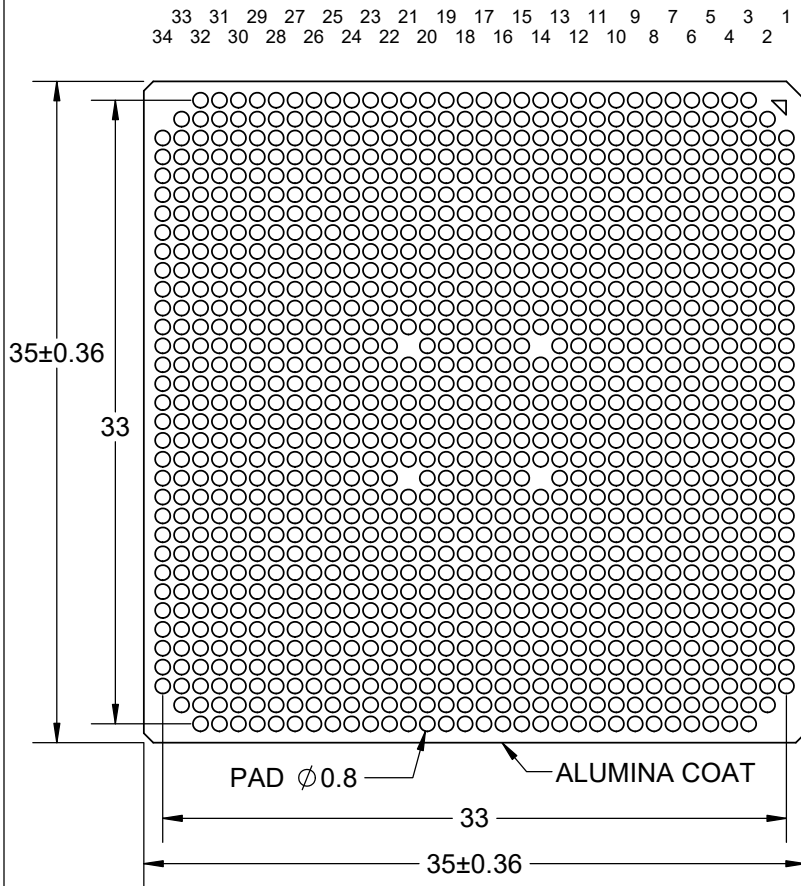

SHOWN WITHOUT DIE

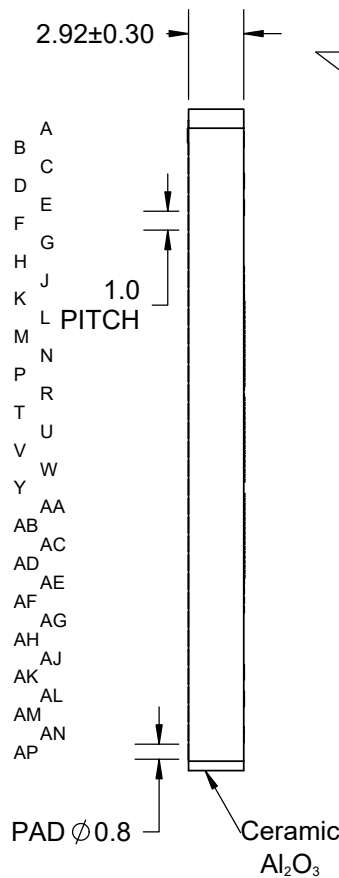

TOP VIEW

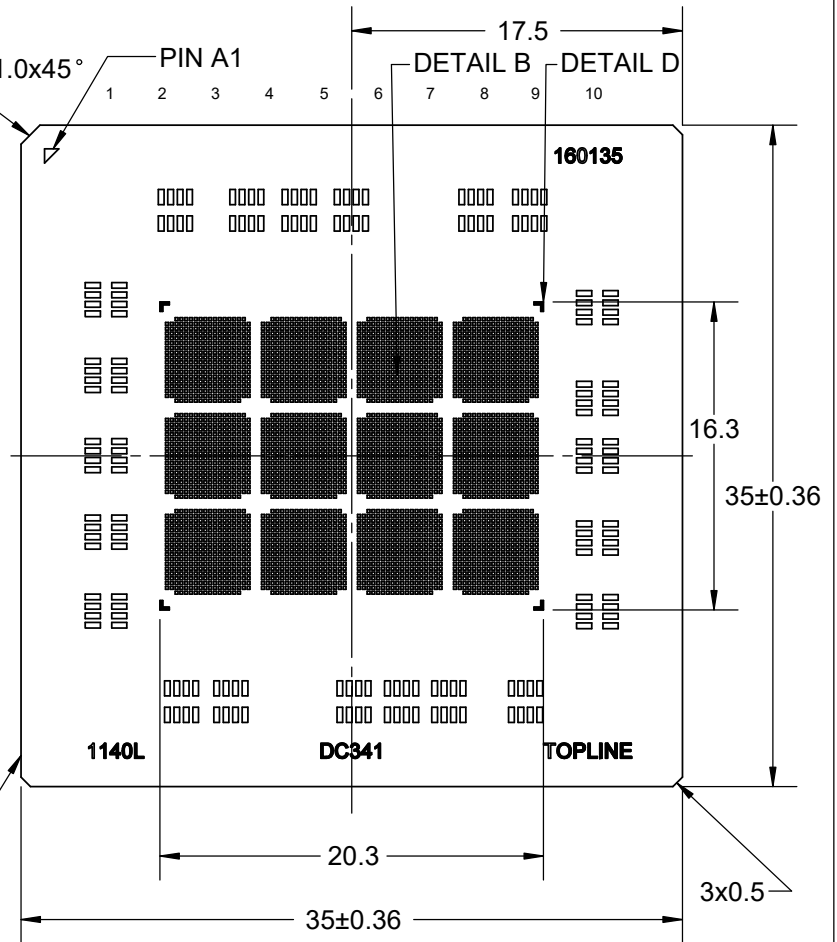

NOTES:

1. PLATING TOP AND BOTTOM
ELECTROLESS Ni 3.2~8.89µm (125~350 micro- inch).
ELECTROLESS Au 0.25µm (10 micro-inch) MAX).
2. WEIGHT 12.88 GRAM (EST.).

DETAIL A CAPACITOR ARRAY



0508

Notes: (Unless Otherwise Specified).

- 1) DIMENSIONS ARE IN mm.
- 2) CLGA SHOWN WITHOUT COLUMNS.
- 3) SHOWN WITHOUT HEAT SINK.
- 4) SHOWN WITHOUT DUMMY DIE.
- 5) SHOWN WITHOUT CAPACITORS.

PART NUMBER OPTIONS				
PART NUMBER	DUMMY DIE	SOLDER PIN	HEAT SINK	CAPACITOR
CLGA1140T1.0-DC341	NONE	NONE	NONE	NONE

APPROVALS	DATE				
DRAWN T.Au	10/30/2016				
ENG M. Hart	10/30/2016	TITLE		CLGA1140T1.0-DC341 DAISY CHAIN	
MFG		SCALE	SIZE	DRAWING NO.	REV
QA		2.5:1	A	160135	A
CUST		DO NOT SCALE DRAWING			SHEET 1 OF 16
REVISED					

BOTTOM VIEW

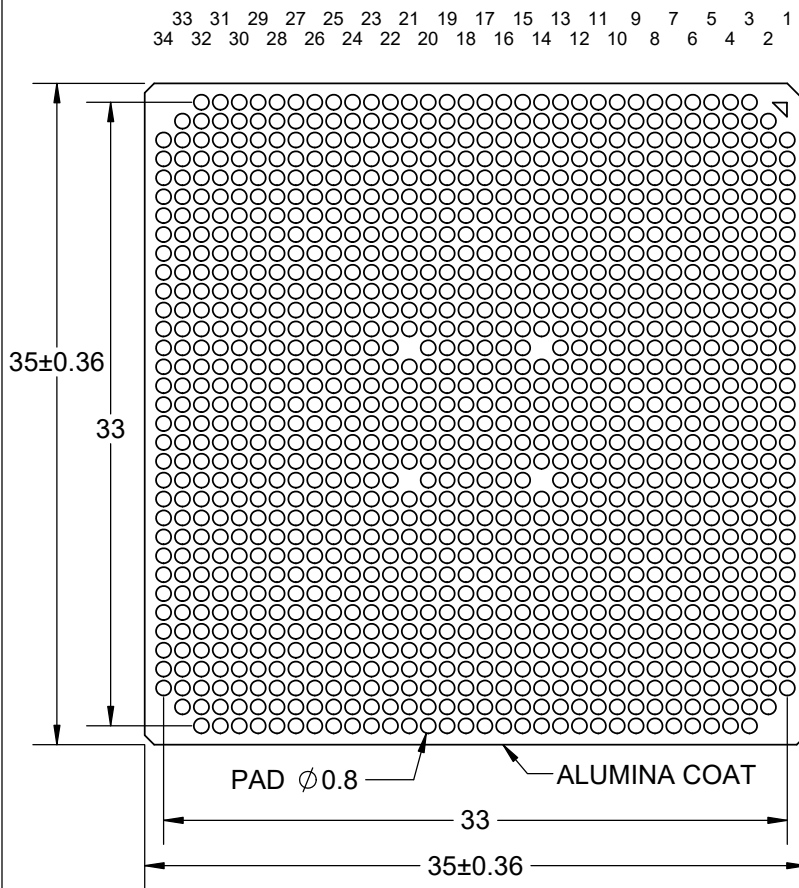

SHOWN WITH DIE

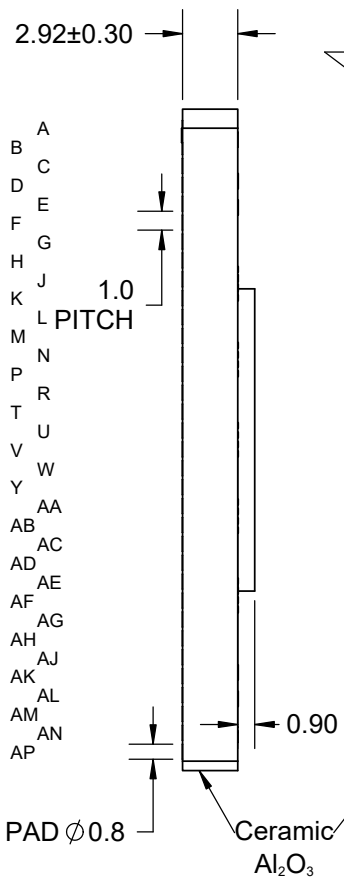

TOP VIEW

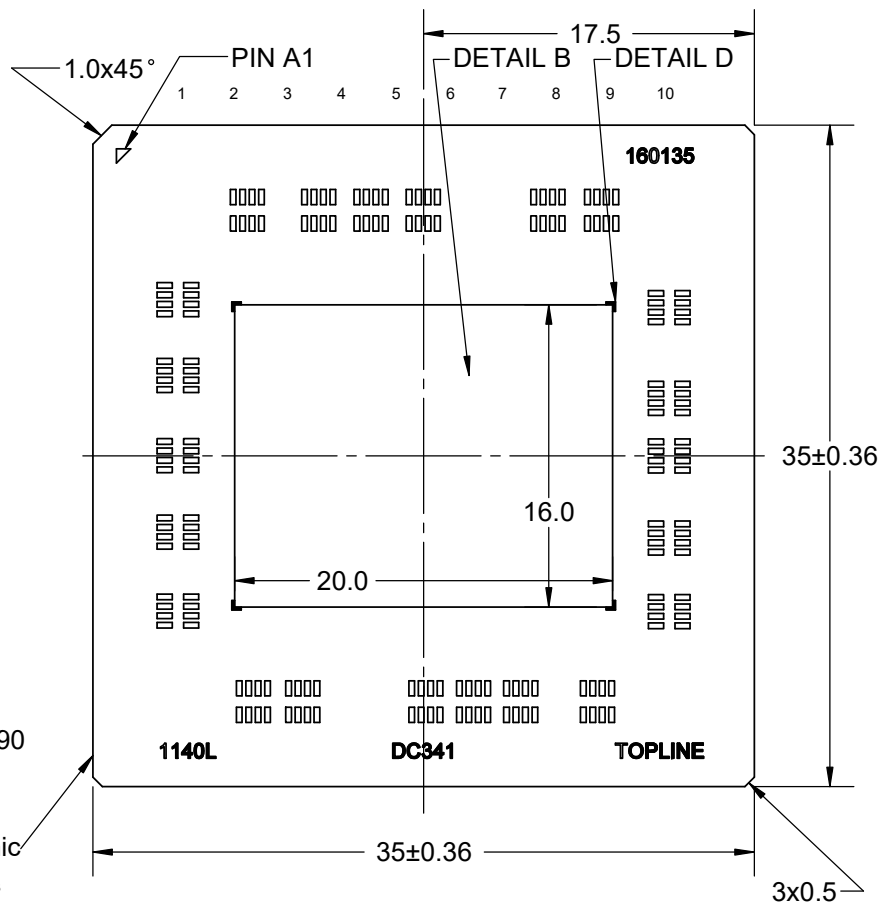

NOTES:

1. PLATING TOP AND BOTTOM
ELECTROLESS Ni 3.2~8.89µm (125~350 micro-inch).
ELECTROLESS Au 0.25µm (10 micro-inch) MAX).

DETAIL A CAPACITOR ARRAY



0508

Notes: (Unless Otherwise Specified).

- 1) DIMENSIONS ARE IN mm.
- 2) CLGA SHOWN WITHOUT COLUMNS.
- 3) SHOWN WITHOUT HEAT SINK.
- 4) SHOWN WITH DUMMY DIE.
- 5) SHOWN WITHOUT CAPACITORS.

PART NUMBER OPTIONS				
PART NUMBER	DUMMY DIE	SOLDER PIN	HEAT SINK	CAPACITOR
CLGA1140T1.0-DC341D	NONE	NONE	NONE	NONE

APPROVALS		DATE				
DRAWN	T. Au	10/30/2016				
ENG	M. Hart	10/30/2016	TITLE		CLGA1140T1.0-DC341 DAISY CHAIN	
MFG			SCALE	SIZE	DRAWING NO.	REV
QA			2.5:1	A	160135	A
CUST			DO NOT SCALE DRAWING			SHEET 2 OF 16
REVISED						

BOTTOM VIEW

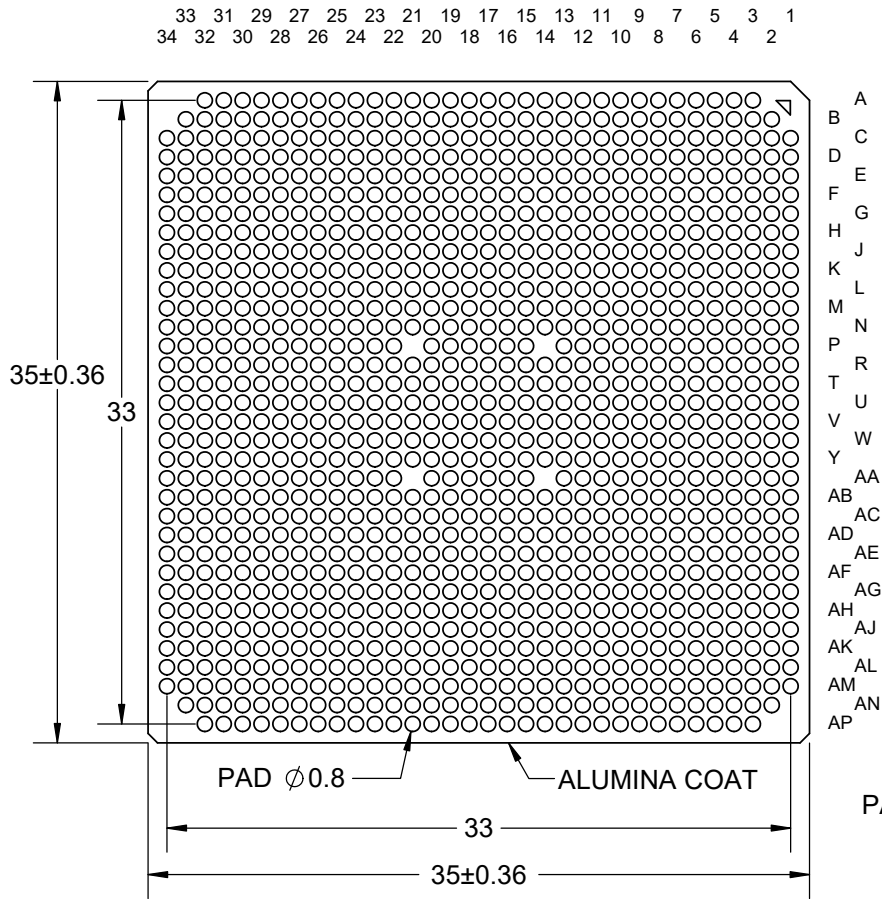

TOP VIEW

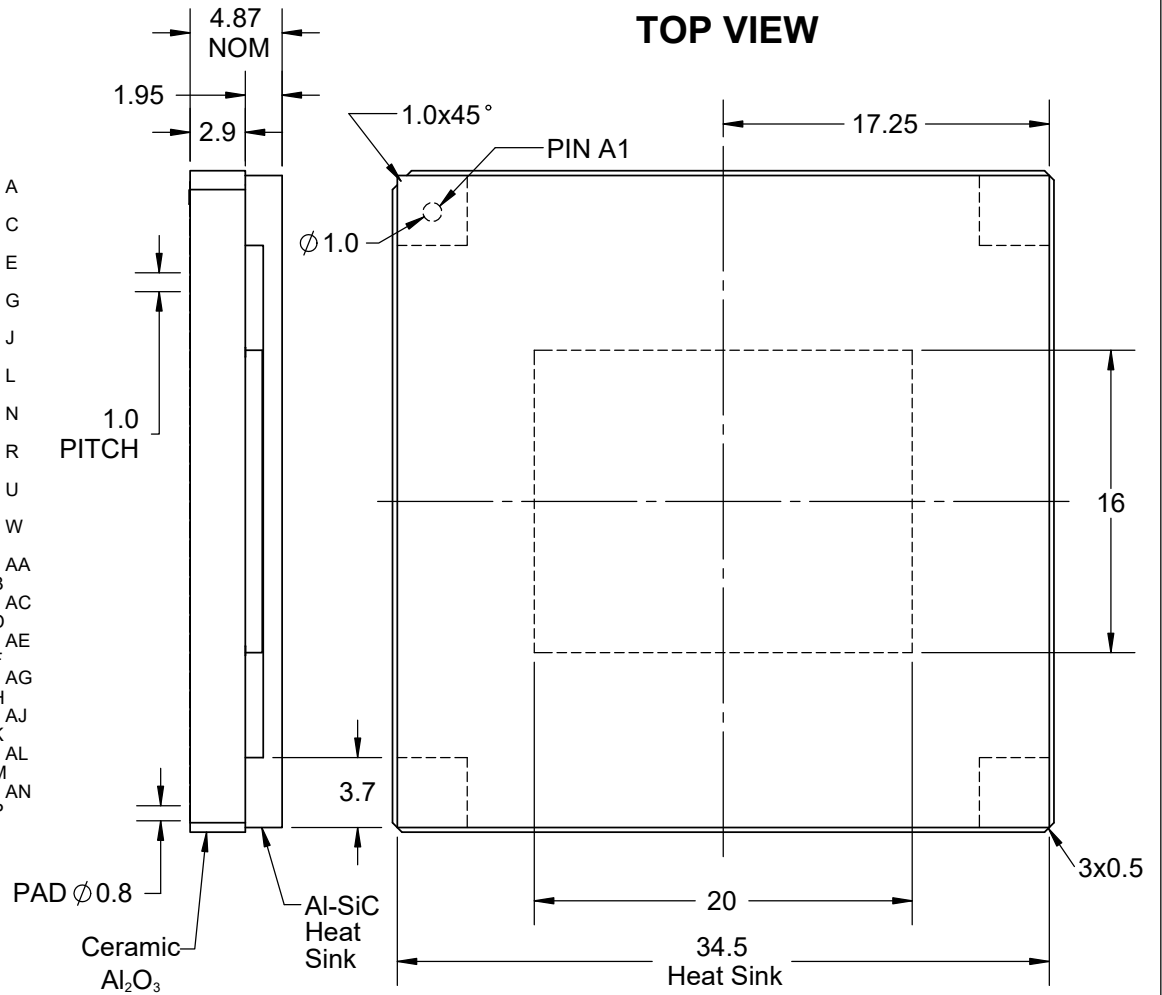

NOTES:

1. PLATING TOP AND BOTTOM
ELECTROLESS Ni 3.2~8.89µm (125~350 micro-inch).
ELECTROLESS Au 0.25µm (10 micro-inch) MAX).

Notes: (Unless Otherwise Specified).

- 1) DIMENSIONS ARE IN mm.
- 2) CLGA SHOWN WITHOUT COLUMNS.
- 3) SHOWN WITH CN HEAT SINK.

PART NUMBER OPTIONS				
PART NUMBER	DUMMY DIE	SOLDER PIN	HEAT SINK	CAPACITOR
CLGA1140T1.0-DC341CN	YES	NONE	YES	NONE

APPROVALS	DATE	TopLine®			
DRAWN T. Au	10/30/2016				
ENG M. Hart	10/30/2016	TITLE CLGA1140T1.0-DC341 DAISY CHAIN			
MFG		SCALE 2.5:1	SIZE A	DRAWING NO. 160135	REV A
QA		DO NOT SCALE DRAWING			SHEET 3 OF 16
CUST					
REVISED					

BOTTOM VIEW

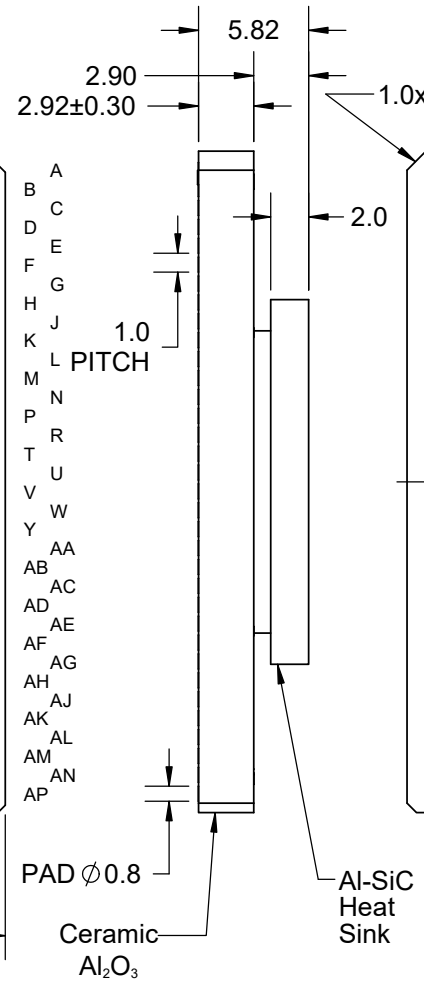
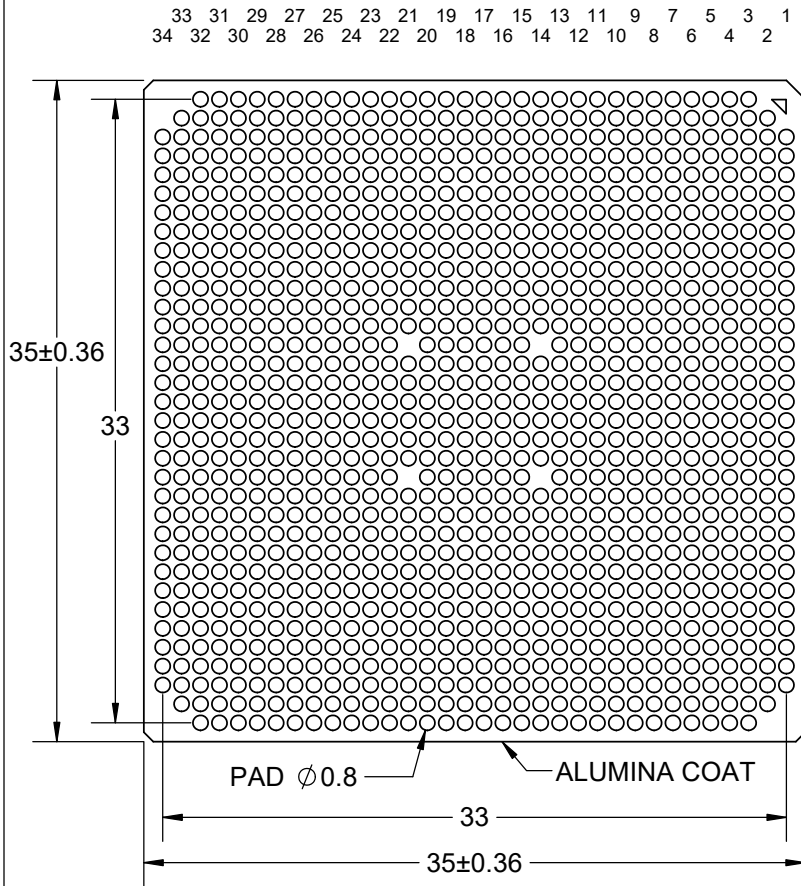

TOP VIEW

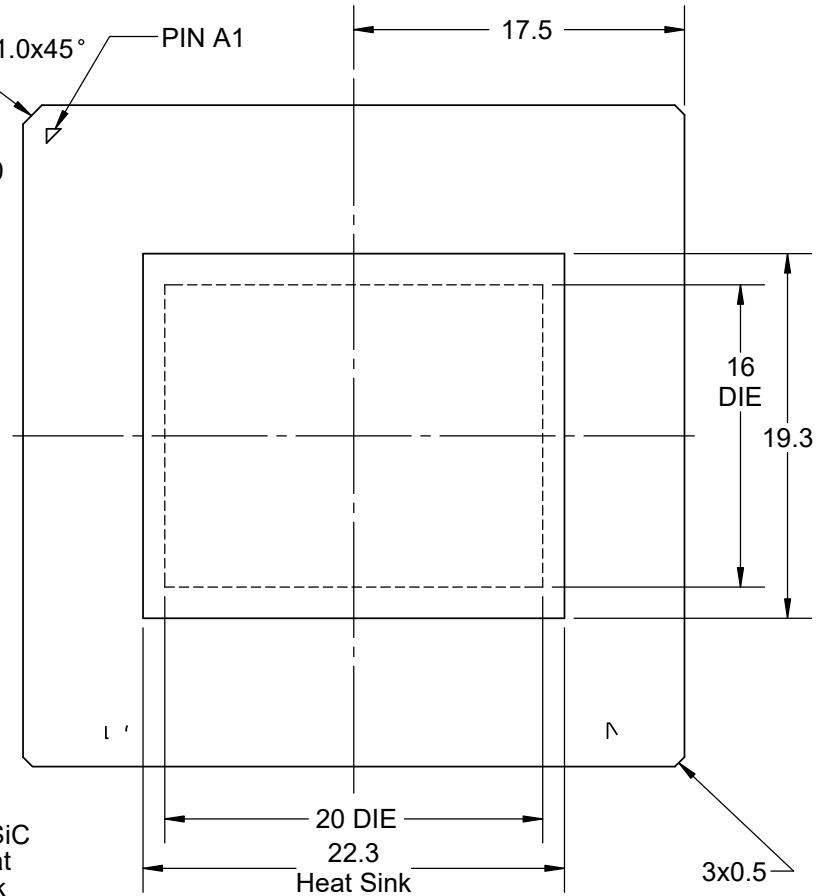

NOTES:

1. PLATING TOP AND BOTTOM
ELECTROLESS Ni 3.2~8.89µm (125~350 micro-inch).
ELECTROLESS Au 0.25µm (10 micro-inch) MAX).

- Notes: (Unless Otherwise Specified).
1) DIMENSIONS ARE IN mm.
2) CLGA SHOWN WITHOUT COLUMNS.
3) SHOWN WITH CF HEAT SINK

PART NUMBER OPTIONS				
PART NUMBER	DUMMY DIE	SOLDER PIN	HEAT SINK	CAPACITOR
CLGA1140T1.0-DC341CF	YES	NONE	YES	NONE

APPROVALS	DATE	TopLine®			
DRAWN T.Au	10/30/2016				
ENG M. Hart	10/30/2016	TITLE CLGA1140T1.0-DC341 DAISY CHAIN			
MFG		SCALE 2.5:1	SIZE A	DRAWING NO. 160135	REV A
QA		DO NOT SCALE DRAWING			SHEET 4 OF 16
CUST					
REVISED					

BOTTOM VIEW

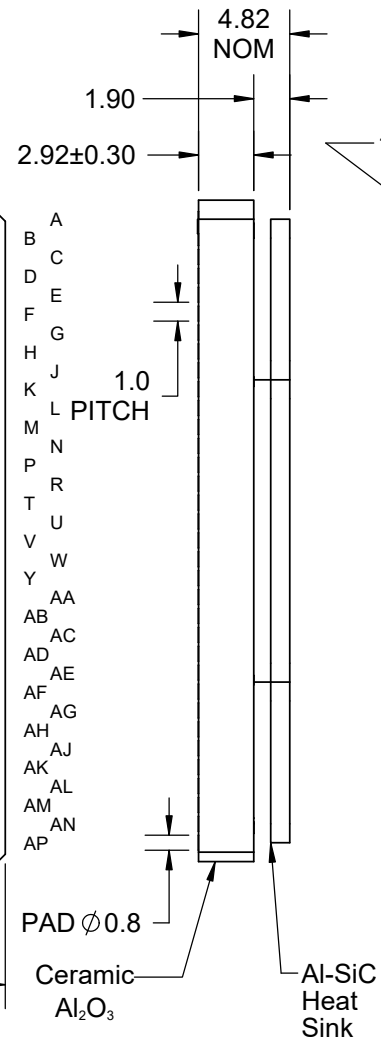
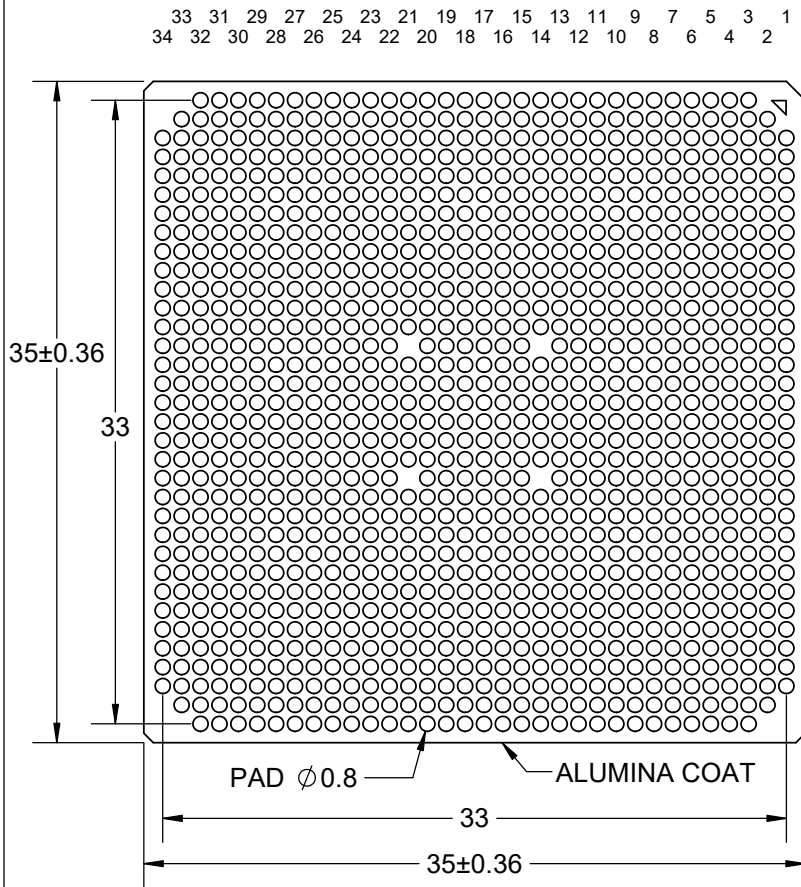

TOP VIEW

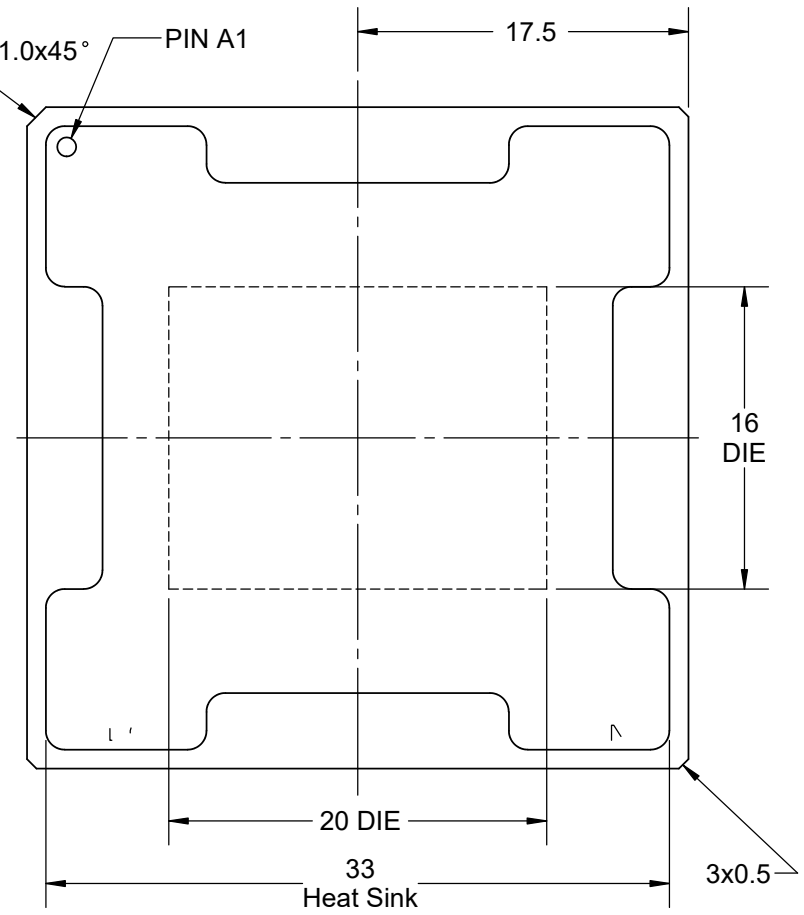

NOTES:

1. PLATING TOP AND BOTTOM
ELECTROLESS Ni 3.2~8.89µm (125~350 micro-inch).
ELECTROLESS Au 0.25µm (10 micro-inch) MAX).

- Notes: (Unless Otherwise Specified).
1) DIMENSIONS ARE IN mm.
2) CLGA SHOWN WITHOUT COLUMNS.
3) SHOWN WITH CF4 HEAT SINK

PART NUMBER OPTIONS				
PART NUMBER	DUMMY DIE	SOLDER PIN	HEAT SINK	CAPACITOR
CLGA1140T1.0-DC341CF4	YES	NONE	YES	NONE

APPROVALS	DATE	TopLine®			
DRAWN T. Au	10/30/2016				
ENG M. Hart	10/30/2016	TITLE CLGA1140T1.0-DC341 DAISY CHAIN			
MFG		SCALE 2.5:1	SIZE A	DRAWING NO. 160135	REV A
QA		DO NOT SCALE DRAWING			SHEET 5 OF 16
CUST					
REVISED					

DAISY CHAIN PATTERN

COLUMN (BALL) VIEW

33 31 29 27 25 23 21 19 17 15 13 11 9 7 5 3 1
34 32 30 28 26 24 22 20 18 16 14 12 10 8 6 4 2

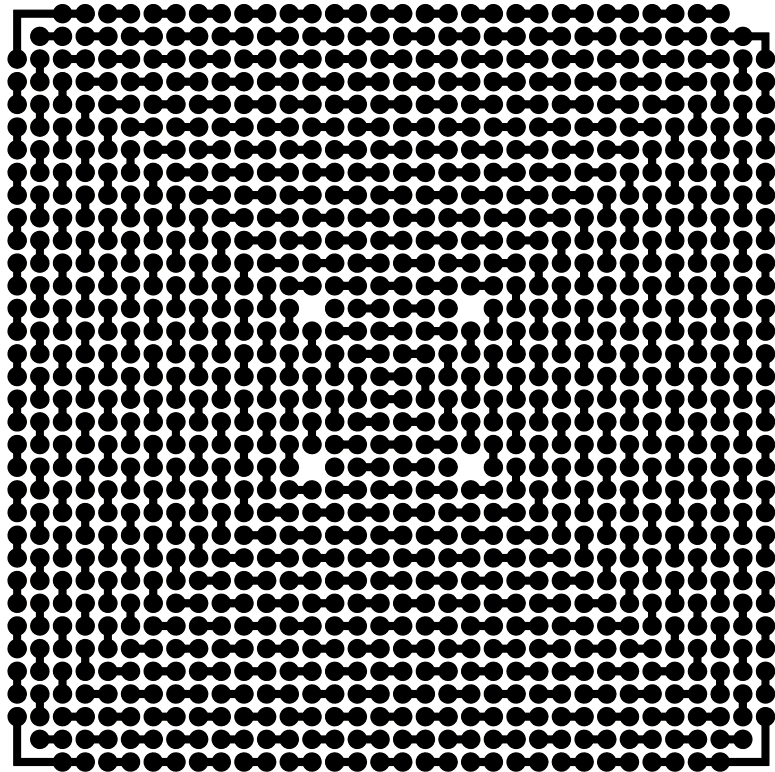

A
B
C
D
E
F
G
H
J
K
L
M
N
P
R
T
U
V
W
Y
AA
AB
AC
AD
AE
AF
AG
AH
AJ
AK
AL
AM
AN
AP

BOTTOM X-RAY VIEWED FROM TOP

2 4 6 8 10 12 14 16 18 20 22 24 26 28 30 32 34
1 3 5 7 9 11 13 15 17 19 21 23 25 27 29 31 33

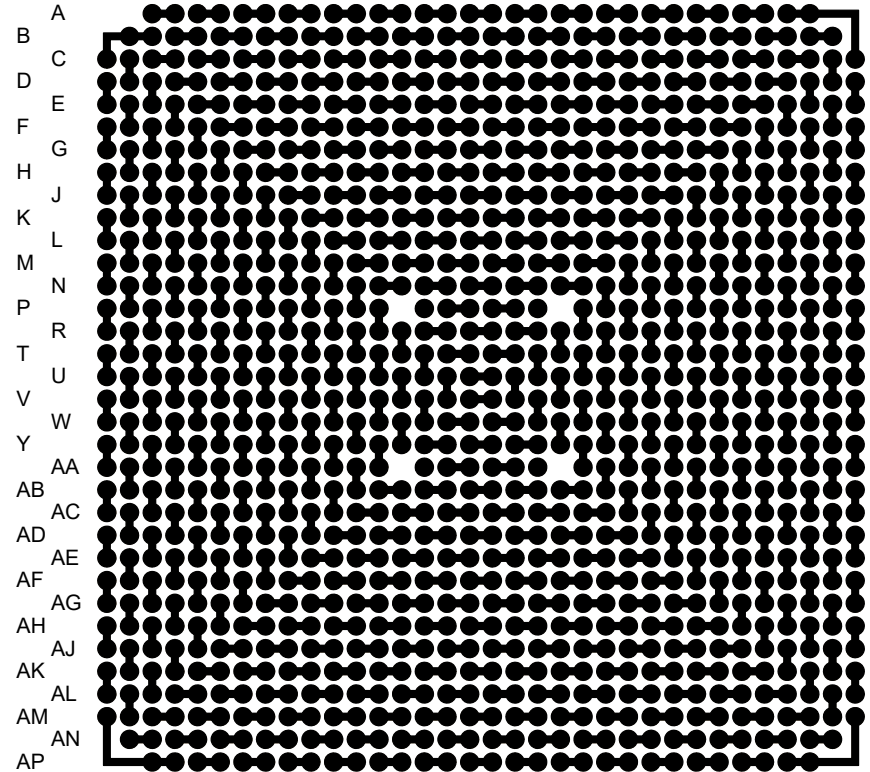

A
B
C
D
E
F
G
H
J
K
L
M
N
P
R
T
U
V
W
Y
AA
AB
AC
AD
AE
AF
AG
AH
AJ
AK
AL
AM
AN
AP

TopLine[®]

TITLE CLGA1140T1.0-DC341
DAISY CHAIN

SCALE 3:1	SIZE A	DRAWING NO. 160135	REV A
--------------	-----------	-----------------------	----------

DO NOT SCALE DRAWING

SHEET 6 OF 16

DC PAIR	
A11	A12
A13	A14
A15	A16
A17	A18
A19	A20
A21	A22
A23	A24
A25	A26
A27	A28
A29	A30
A3	A4
A5	A6
A7	A8
A9	A10
AA1	Y1
AA10	AB10
AA11	Y11
AA12	AB12
AA13	Y13
	AA15
AA16	AA17
AA18	AA19
AA2	AB2
AA20	
AA22	Y22
AA23	AB23
AA24	Y24
AA25	AB25
AA26	Y26
AA27	AB27
AA28	Y28
AA29	AB29
AA3	Y3
AA30	Y30
AA31	AB31
AA32	Y32
AA33	AB33
AA34	Y34
AA4	AB4
AA5	Y5
AA6	AB6
AA7	Y7
AA8	AB8

DC PAIR	
AA9	Y9
AB1	AC1
AB11	AC11
AB13	AB14
AB15	AB16
AB17	AB18
AB19	AB20
AB21	AB22
AB24	AC24
AB26	AC26
AB28	AC28
AB3	AC3
AB30	AC30
AB32	AC32
AB34	AC34
AB5	AC5
AB7	AC7
AB9	AC9
AC10	AD10
AC12	AC13
AC14	AC15
AC16	AC17
AC18	AC19
AC2	AD2
AC20	AC21
AC22	AC23
AC25	AD25
AC27	AD27
AC29	AD29
AC31	AD31
AC33	AD33
AC4	AD4
AC6	AD6
AC8	AD8
AD1	AE1
AD11	AD12
AD13	AD14
AD15	AD16
AD17	AD18
AD19	AD20
AD21	AD22
AD23	AD24
AD26	AE26

DC PAIR	
AD28	AE28
AD3	AE3
AD30	AE30
AD32	AE32
AD34	AE34
AD5	AE5
AD7	AE7
AD9	AE9
AE10	AE11
AE12	AE13
AE14	AE15
AE16	AE17
AE18	AE19
AE2	AF2
AE20	AE21
AE22	AE23
AE24	AE25
AE27	AF27
AE29	AF29
AE31	AF31
AE33	AF33
AE4	AF4
AE6	AF6
AE8	AF8
AF1	AG1
AF11	AF12
AF13	AF14
AF15	AF16
AF17	AF18
AF19	AF20
AF21	AF22
AF23	AF24
AF25	AF26
AF28	AG28
AF3	AG3
AF30	AG30
AF32	AG32
AF34	AG34
AF5	AG5
AF7	AG7
AF9	AF10
AG10	AG11
AG12	AG13

DC PAIR	
AG14	AH15
AG16	AG17
AG18	AG19
AG2	AH2
AG20	AG21
AG22	AG23
AG24	AG25
AG26	AG27
AG29	AH29
AG31	AH31
AG33	AH33
AG4	AH4
AG6	AH6
AG8	AG9
AH1	AJ1
AH11	AH12
AH13	AH14
AH15	AH16
AH17	AH18
AH19	AH20
AH21	AH22
AH23	AH24
AH25	AH26
AH27	AH28
AH3	AJ3
AH30	AJ30
AH32	AJ32
AH34	AJ34
AH5	AJ5
AH7	AH8
AH9	AJ10
AJ10	AJ11
AJ12	AJ13
AJ14	AJ15
AJ16	AJ17
AJ18	AJ19
AJ2	AK2
AJ20	AJ21
AJ22	AJ23
AJ24	AJ25
AJ26	AJ27
AJ28	AJ29
AJ31	AK31

DC PAIR	
AJ33	AK33
AJ4	AK4
AJ6	AJ7
AJ8	AJ9
AK1	AL1
AK11	AK12
AK13	AK14
AK15	AK16
AK17	AK18
AK19	AK20
AK21	AK22
AK23	AK24
AK25	AK26
AK27	AK28
AK29	AK30
AK3	AL3
AK32	AL32
AK34	AL34
AK5	AK6
AK7	AK8
AK9	AK10
AL10	AL11
AL12	AL13
AL14	AL15
AL16	AL17
AL18	AL19
AL2	AM2
AL20	AL21
AL22	AL23
AL24	AL25
AL26	AL27
AL28	AL29
AL30	AL31
AL33	AM33
AL4	AL5
AL6	AL7
AL8	AL9
AM11	AM12
AM13	AM14
AM15	AM16
AM17	AM18
AM19	AM20
AM21	AM22

DC PAIR	
AM23	AM24
AM25	AM26
AM27	AM28
AM29	AM30
AM3	AM4
AM31	AM32
AM5	AM6
AM7	AM8
AM9	AM10
AN10	AN11
AN12	AN13
AN14	AN15
AN16	AN17
AN18	AN19
AN2	AN3
AN20	AN21
AN22	AN23
AN24	AN25
AN26	AN27
AN28	AN29
AN30	AN31
AN32	AN33
AN4	AN5
AN6	AN7
AN8	AN9
AP11	AP12
AP13	AP14
AP15	AP16
AP17	AP18
AP19	AP20
AP21	AP22
AP23	AP24
AP25	AP26
AP27	AP28
AP29	AP30
AP5	AP6
AP7	AP8
AP9	AP10
B10	B11
B12	B13
B14	B15
B16	B17
B18	B19

NET LIST DAISY CHAIN CONNECTION TABLE

CONTINUED NEXT PAGE

TopLine®			
TITLE CLGA1140T1.0-DC341 DAISY CHAIN			
SCALE NONE	SIZE A	DRAWING NO. 160135	REV A
DO NOT SCALE DRAWING			SHEET 7 OF 16

DC PAIR	
B20	B21
B22	B23
B24	B25
B26	B27
B28	B29
B30	B31
B32	B33
B4	B5
B6	B7
B8	B9
C11	C12
C13	C14
C15	C16
C17	C18
C19	C20
C2	D2
C21	C22
C23	C24
C25	C26
C27	C28
C29	C30
C3	C4
C31	C32
C33	D33
C5	C6
C7	C8
C9	C10
D1	E1
D10	D11
D12	D13
D14	D15
D16	D17
D18	D19
D20	D21
D22	D23
D24	D25
D26	D27
D28	D29
D3	E3
D30	D31
D32	E32
D34	E34
D4	D5

DC PAIR	
D6	D7
D8	D9
E11	E12
E13	E14
E15	E16
E17	E18
E19	E20
E2	F2
E21	E22
E23	E24
E25	E26
E27	E28
E29	E30
E31	F31
E33	F33
E4	F4
E5	E6
E7	E8
E9	E10
F1	G1
F10	F11
F12	F13
F14	F15
F16	F17
F18	F19
F20	F21
F22	F23
F24	F25
F26	F27
F28	F29
F3	G3
F30	G30
F32	G32
F34	G34
F5	G5
F6	F7
F8	F9
G11	G12
G13	G14
G15	G16
G17	G18
G19	G20
G2	H2

DC PAIR	
G21	G22
G23	G24
G25	G26
G27	G28
G29	H29
G31	H31
G33	H33
G4	H4
G6	H6
G7	G8
G9	G10
H1	J1
H10	H11
H12	H13
H14	H15
H16	H17
H18	H19
H20	H21
H22	H23
H24	H25
H26	H27
H28	J28
H3	J3
H30	J30
H32	J32
H34	J34
H5	J5
H7	J7
H8	H9
J11	J12
J13	J14
J15	J16
J17	J18
J19	J20
J2	K2
J21	J22
J23	J24
J25	J26
J27	K27
J29	K29
J31	K31
J33	K33
J4	K4

DC PAIR	
J6	K6
J8	K8
J9	J10
K1	L1
K10	K11
K12	K13
K14	K15
K16	K17
K18	K19
K20	K21
K22	K23
K24	K25
K26	L26
K28	L28
K34	L3
K30	L30
K32	L32
K3	L34
K5	L5
K7	L7
K9	L9
L10	M10
L11	L12
L13	L14
L15	L16
L17	L18
L19	L20
L2	M2
L21	L22
L23	L24
L25	M25
L27	M27
L29	M29
L31	M31
L33	M33
L4	M4
L6	M6
L8	M8
M1	N1
M11	N11
M12	M13
M14	M15
M16	M17

DC PAIR	
M18	M19
M20	M21
M22	M23
M24	N24
M26	N26
M28	N28
M3	N3
M30	N30
M32	N32
M34	N34
M5	N5
M7	N7
M9	N9
N10	P10
N12	P12
N13	N14
N15	N16
N17	N18
N19	N20
N2	P2
N21	N22
N23	P23
N25	P25
N27	P27
N29	P29
N31	P31
N33	P33
N4	P4
N6	P6
N8	P8
P1	R1
P11	R11
P13	R13
	P15
P16	P17
P18	P19
P20	
P22	R22
P24	R24
P26	R26
P28	R28
P3	R3
P30	R30

DC PAIR	
P32	R32
P34	R24
P5	R5
P7	R7
P9	R9
R10	T10
R12	T12
R14	T14
R15	R16
R17	R18
R19	R20
R2	T2
R21	T21
R23	T23
R25	T25
R27	T27
R29	T29
R31	T31
R33	T33
R4	T4
R6	T6
R8	T8
T1	U1
T11	U11
T13	U13
T15	U15
T16	T17
T18	T19
T20	U20
T22	U22
T24	U24
T26	U26
T28	U28
T3	U3
T30	U30
T32	U32
T34	U34
T5	U5
T7	U7
T9	U9
U10	V10
U12	V12
U14	V14

NET LIST DAISY CHAIN CONNECTION TABLE

CONTINUED NEXT PAGE

TopLine®			
TITLE CLGA1140T1.0-DC341 DAISY CHAIN			
SCALE NONE	SIZE A	DRAWING NO. 160135	REV A
DO NOT SCALE DRAWING			SHEET 8 OF 16

NET LIST DAISY CHAIN CONNECTION TABLE

DC PAIR	
U16	V16
U17	U18
U19	V19
U2	V2
U21	V21
U23	V23
U25	V25
U27	V27
U29	V29
U31	V31
U33	V33
U4	V4
U6	V6
U8	V8
V1	W1
V11	W11
V13	W13
V15	W15
V17	V19
V20	W20
V22	W22
V24	W24
V26	W26
V28	W28
V3	W3
V30	W30
V32	W32
V34	W34
V5	W5
V7	W7
V9	W9
W10	Y10
W12	Y12
W14	Y14
W16	W17
W18	W19
W2	Y2
W21	Y21
W23	Y23
W25	Y25
W27	Y27
W29	Y29
W31	Y31

DC PAIR	
W33	Y33
W4	Y4
W6	Y6
W8	Y8
Y15	Y16
Y17	Y18
Y19	Y20

PAD 1	PAD 2	PAD 3
AM1	AP3	AP4
AM34	AP31	AP32
B2	B3	C1
A31	A32	C34

TopLine[®]			
TITLE CLGA1140T1.0-DC341 DAISY CHAIN			
SCALE NONE	SIZE A	DRAWING NO. 160135	REV A
DO NOT SCALE DRAWING			SHEET 9 OF 16

DETAIL A

0508 PC BOARD PATTERN

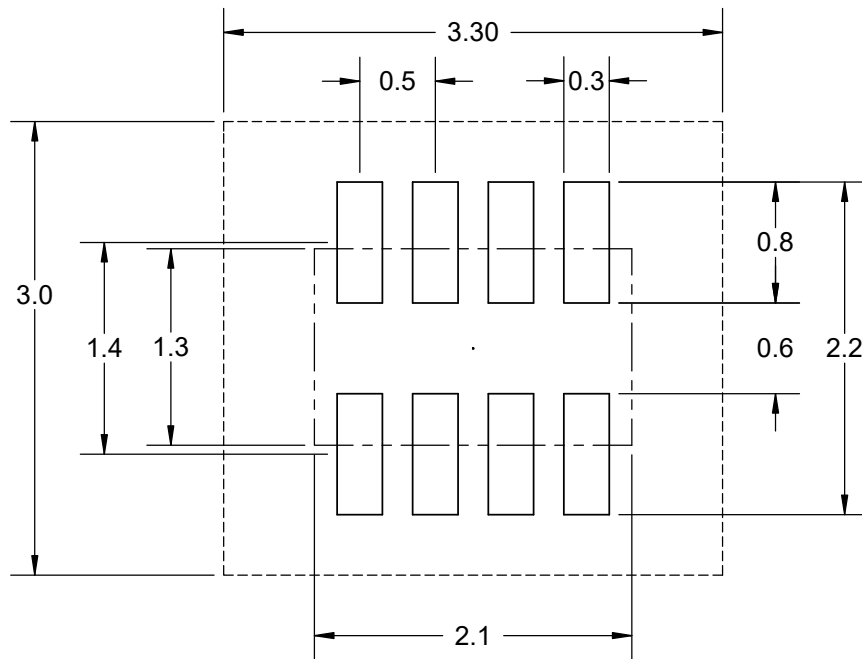

0508 CAPACITOR OUTLINE

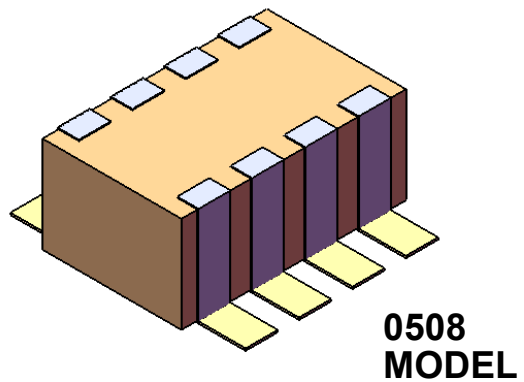
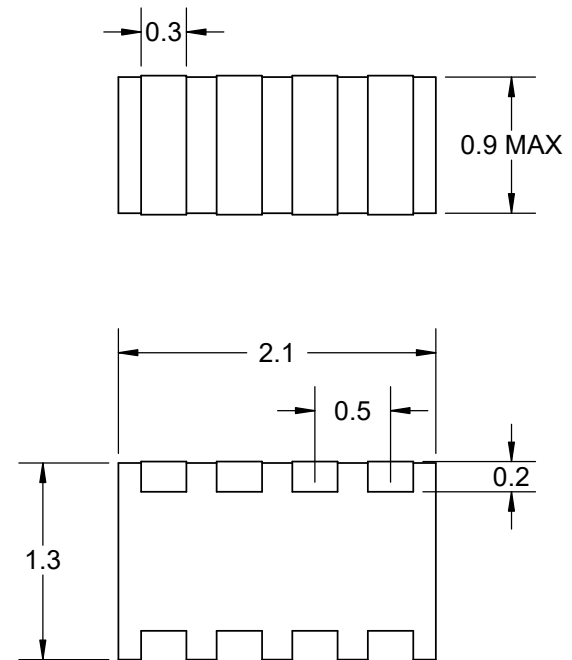

TopLine®			
TITLE		CAPACITOR ARRAY 0508 SIZE	
SCALE	SIZE	DRAWING NO.	REV
20:1	A	160135	A
DO NOT SCALE DRAWING			SHEET 10 OF 16

DETAIL B
PCB DIE PADS (TOP)
 Micron (μm)

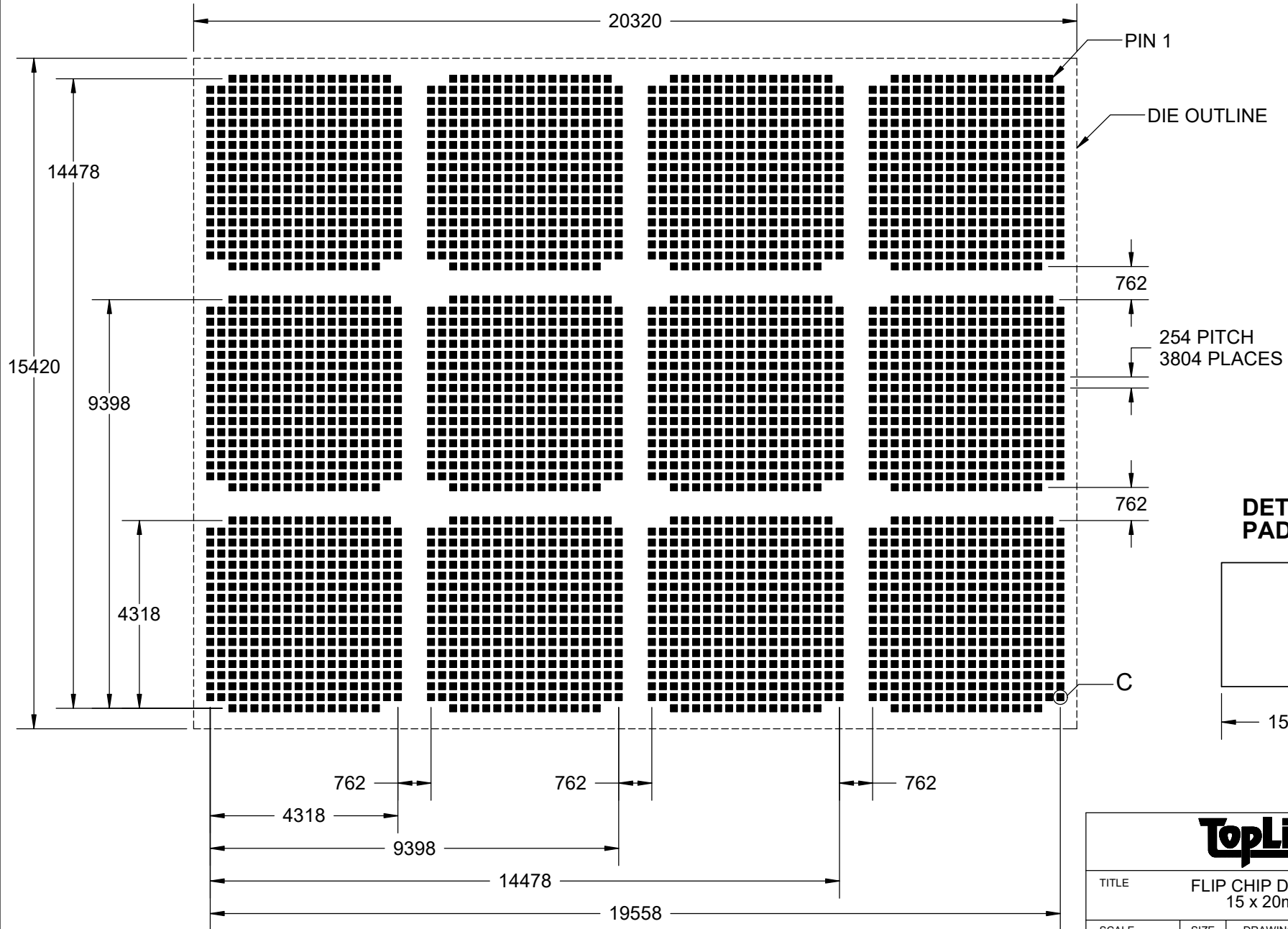

DETAIL C
PAD SIZE

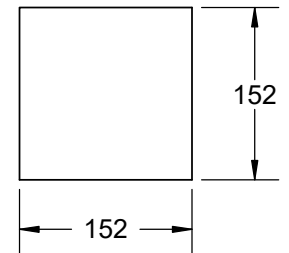

PLATING NOTES: ELECTROLESS Ni 3.2-8.90 μm , ELECTROLESS Au 0.25 μm .

TopLine®			
TITLE		FLIP CHIP DIE PAD 15 x 20mm	
SCALE	SIZE	DRAWING NO.	REV
8:1	A	160135	A
DO NOT SCALE DRAWING			SHEET 11 OF 16

DETAIL D DIE FIDUCIALS

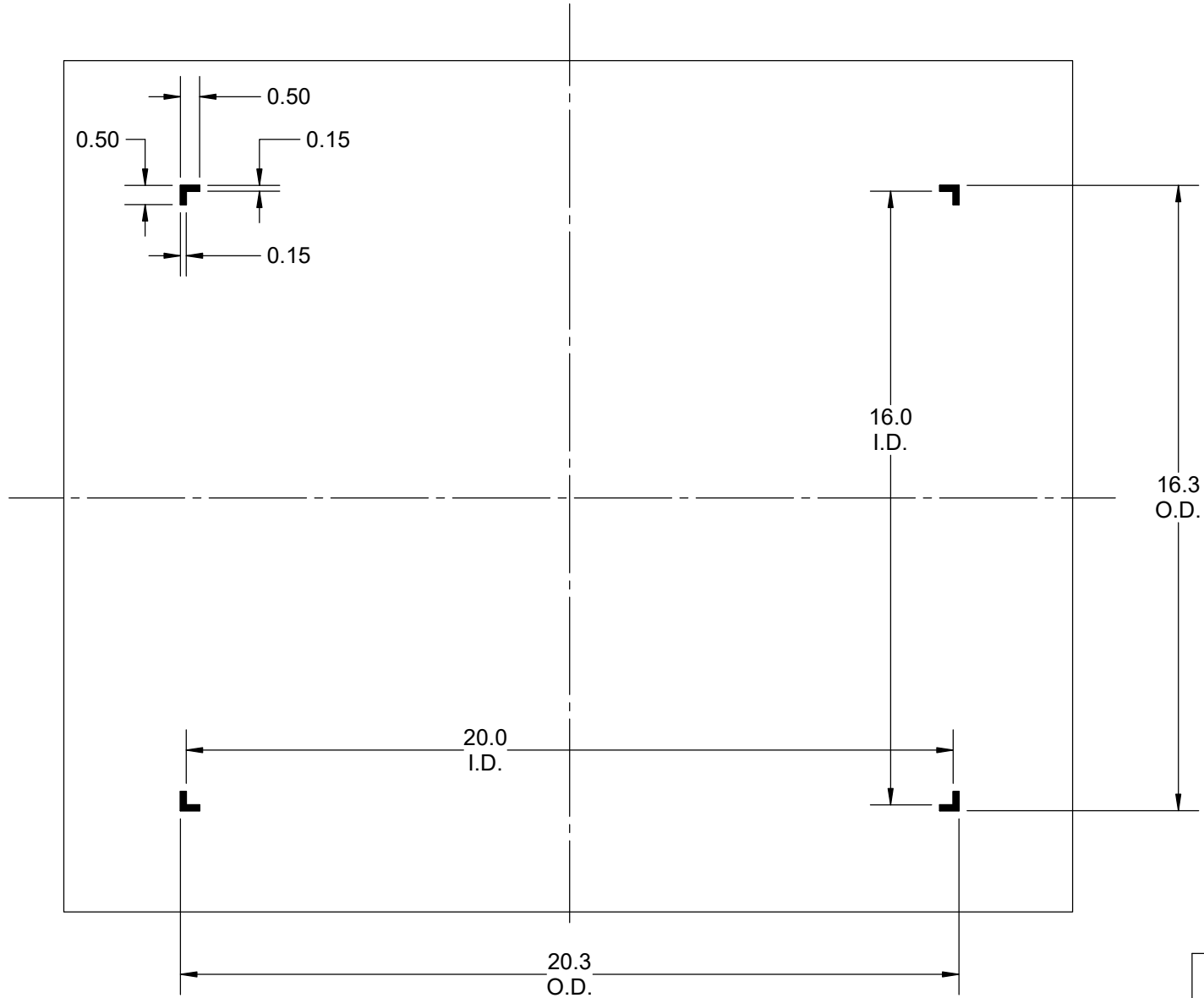

TopLine®

TITLE

DIE FIDUCIAL

SCALE

6:1

SIZE

A

DRAWING NO.

160135

REV

A

DO NOT SCALE DRAWING

SHEET 12 OF 16

BOTTOM VIEW

NEW "CN" STYLE HEAT SPREADER

TOP VIEW

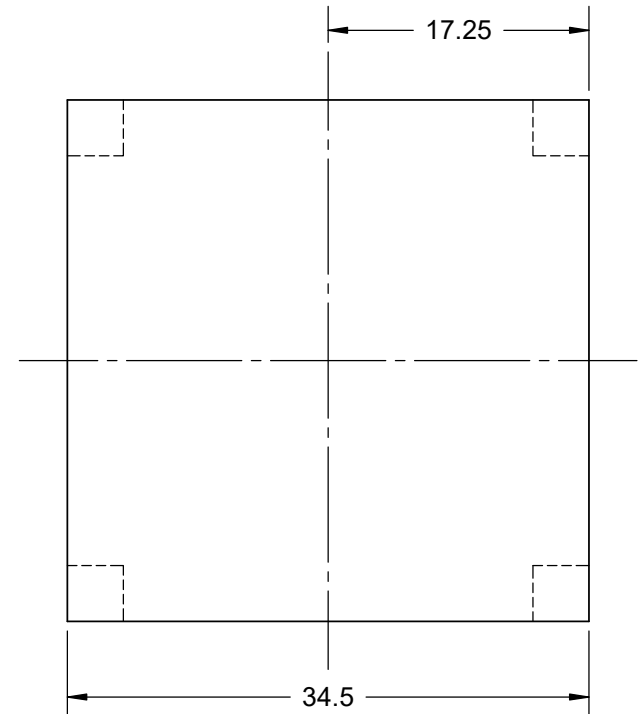
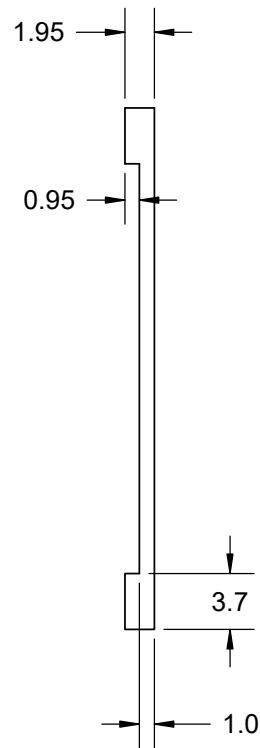
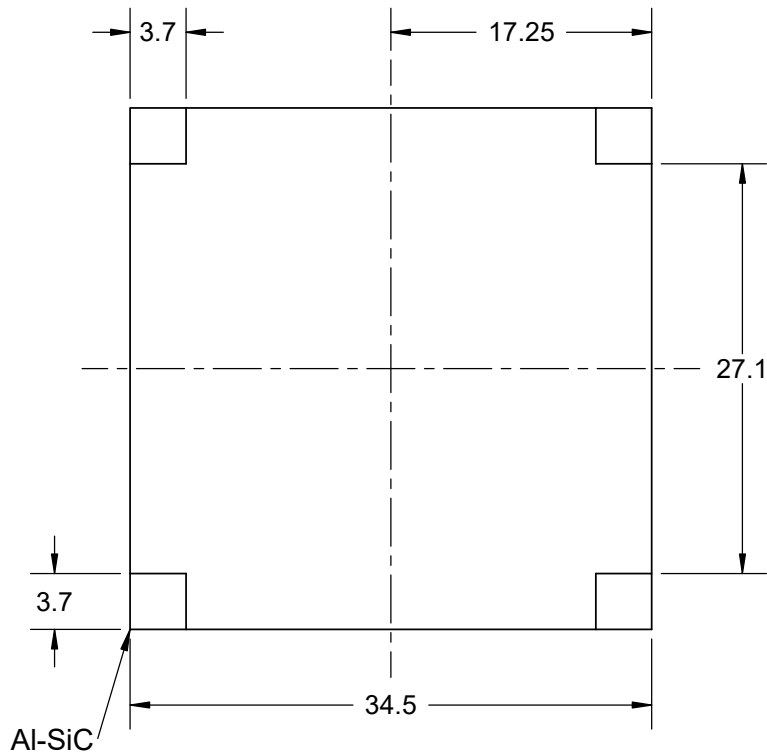

BOTTOM

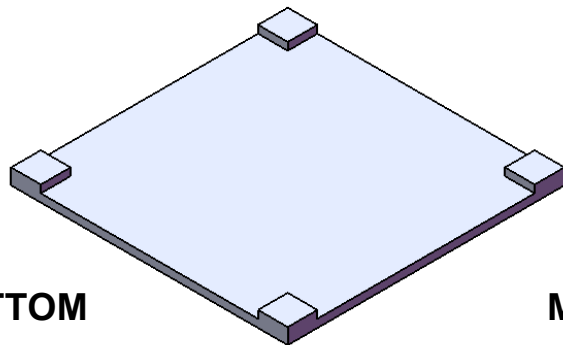

MODELS

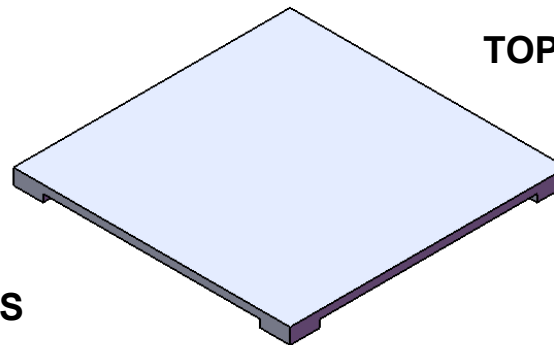

TOP

- NOTES ABOUT HEAT SINK:
 1. DIMENSIONS IN mm.
 2. MATERIAL: Al-SiC HEAT SINK.
 3. NON-HERMETIC.

TopLine®			
TITLE CLGA1140T1.0-DC341 DAISY CHAIN			
SCALE 2:1	SIZE A	DRAWING NO. 160135	REV A
DO NOT SCALE DRAWING			SHEET 13 OF 16

BOTTOM VIEW

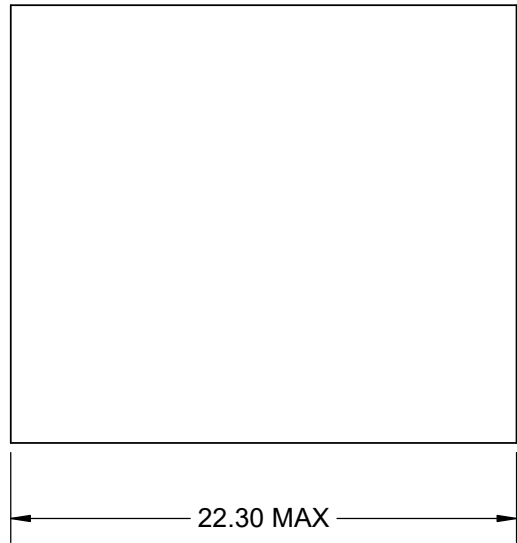

**OLD "CF" STYLE
HEAT SPREADER**

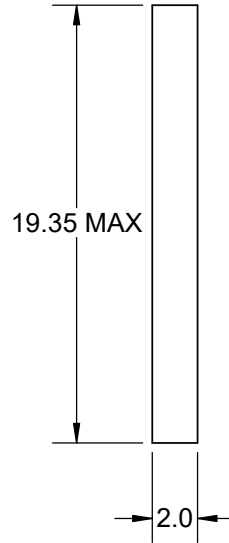

TOP VIEW

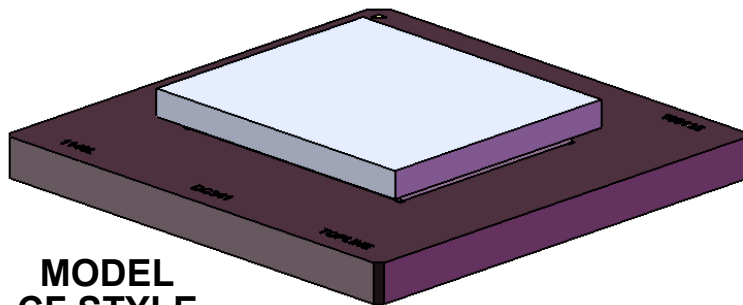
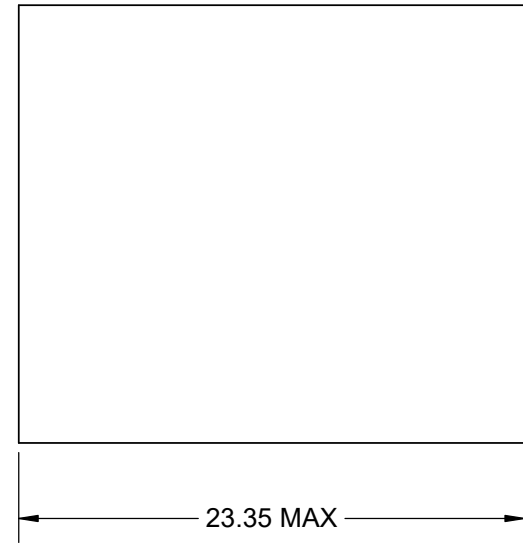

**MODEL
CF STYLE**

NOTES:

1. DIMENSIONS IN mm.
2. MATERIAL: SiC (SILICON CARBIDE).
3. NON-HERMETIC.

TopLine®			
TITLE CLGA1140T1.0-DC341 DAISY CHAIN			
SCALE 3:1	SIZE A	DRAWING NO. 160135	REV A
DO NOT SCALE DRAWING			SHEET 14 OF 16

**COMPARISON SIDE VIEW
 OLD "CF" AND NEW "CN" STYLE**
 Not to Scale
 SHOWN WITHOUT COLUMNS

OLD CF STYLE

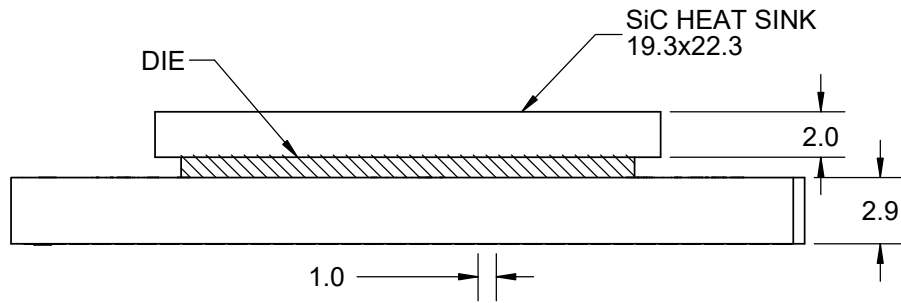

NEW CN STYLE

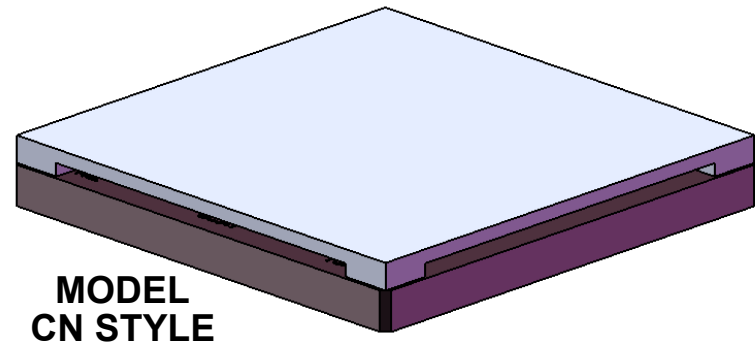
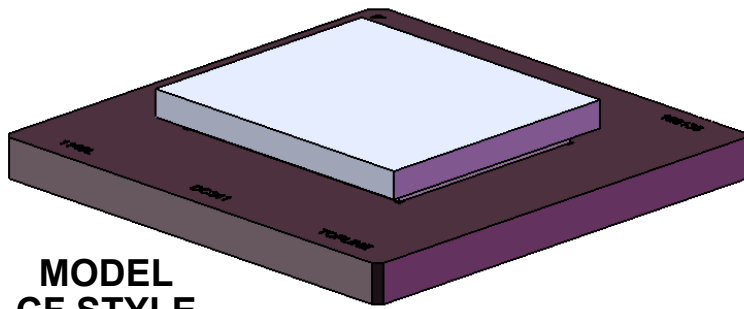
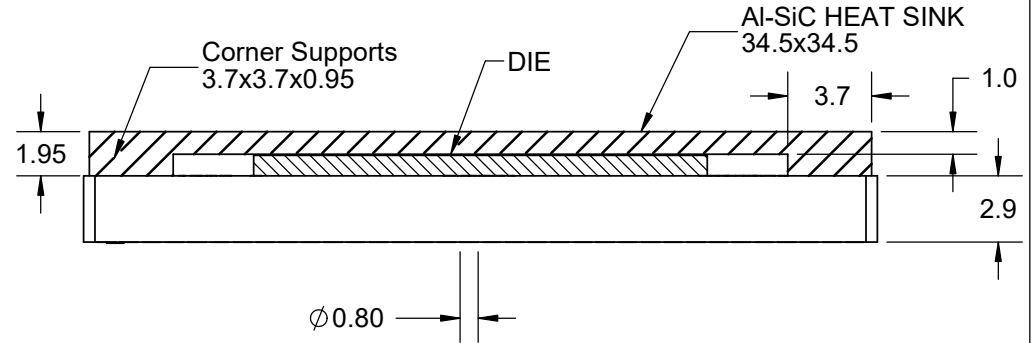

TopLine®			
TITLE CLGA1140T1.0-DC341 DAISY CHAIN			
SCALE 3:1	SIZE A	DRAWING NO. 160135	REV A
DO NOT SCALE DRAWING			SHEET 15 OF 16

CF4 STYLE HEAT SPREADER
 Not to Scale
 SHOWN WITHOUT COLUMNS

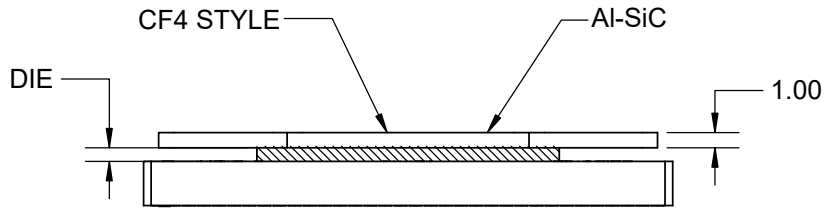

TOP VIEW

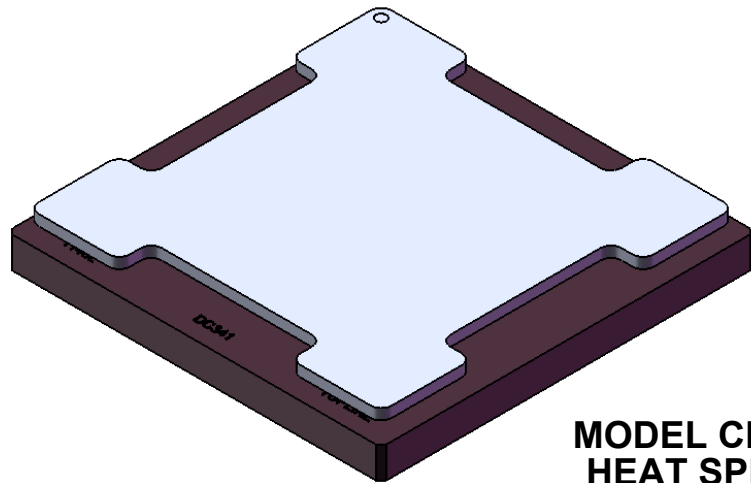
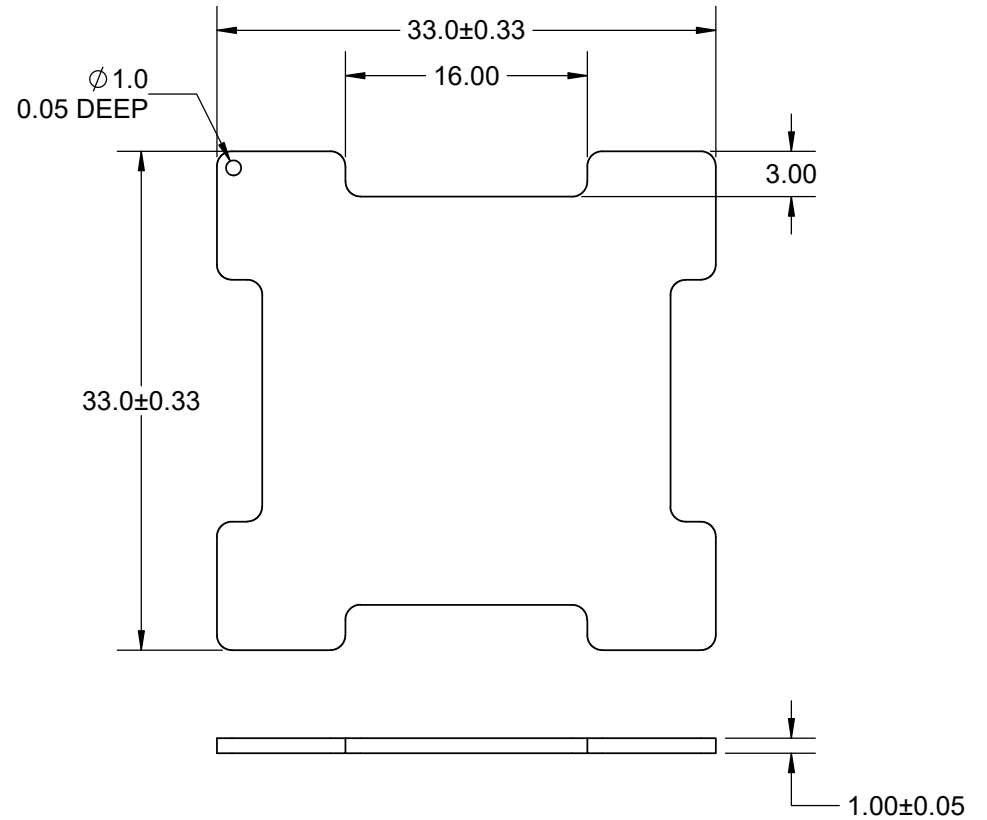

**MODEL CF4 STYLE
 HEAT SPREADER**

TopLine®			
TITLE CLGA1140T1.0-DC341 DAISY CHAIN			
SCALE 2:1	SIZE A	DRAWING NO. 160135	REV A
DO NOT SCALE DRAWING			SHEET 16 OF 16