

No	ANGLE	No	ANGLE
1	0.466 °	27	24.420 °
2	1.447 °	28	25.307 °
3	2.371 °	29	26.136 °
4	3.349 °	30	27.010 °
5	4.270 °	31	27.828 °
6	5.244 °	32	28.689 °
7	6.168 °	33	29.493 °
8	7.136 °	34	30.339 °
9	8.052 °	35	31.135 °
10	9.020 °	36	31.964 °
11	9.935 °	37	32.745 °
12	10.900 °	38	33.562 °
13	11.804 °	39	34.326 °
14	12.764 °	40	35.124 °
15	13.655 °	41	35.876 °
16	14.608 °	42	36.665 °
17	15.500 °	43	37.398 °
18	16.437 °	44	38.171 °
19	17.321 °	45	38.900 °
20	18.254 °	46	39.646 °
21	19.127 °	47	40.349 °
22	20.048 °	48	41.088 °
23	20.916 °	49	41.780 °
24	21.822 °	50	42.501 °
25	22.676 °	51	43.175 °
26	23.574 °	52	43.881 °

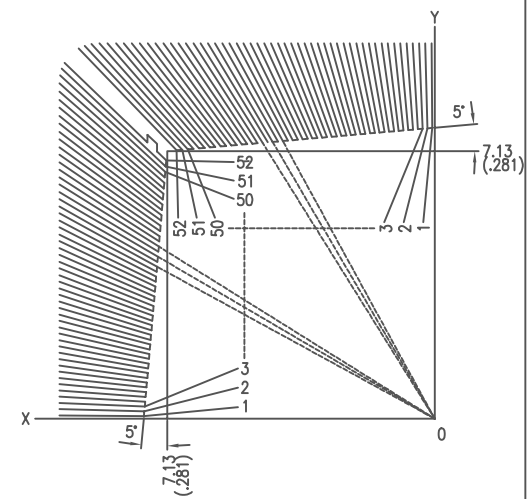

MODIFICATIONS	NAME	208LD QUAD K-PACK'Z'(14.0SQ)	TOLERANCES:	UNLESS OTHERWISE SPECIFIED	DRAWN	K. OHISUKA	CHECKED	K. OKADA
	SCALE	5 : 1	MATERIAL		APPROVED	Y. TORIHARA	DATE	DEC. 5'91
	CHANGE		KYOCERA CORPORATION	KYOTO JAPAN	DWG No.	QC-208349-WZ		
	DATE	DRAWN	CHECKED	APPROVED				