

DO-41 Glass Axial Package

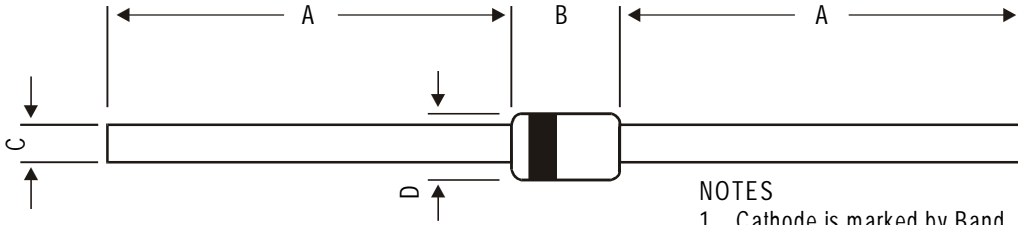

DIM	MIN	MAX
A	27.90	
B	4.06	5.51
C	0.71	0.87
D	2.03	2.72

- NOTES
1. Cathode is marked by Band.
 2. All dimensions are in mm.

DO-41, 52mm Taping Specification

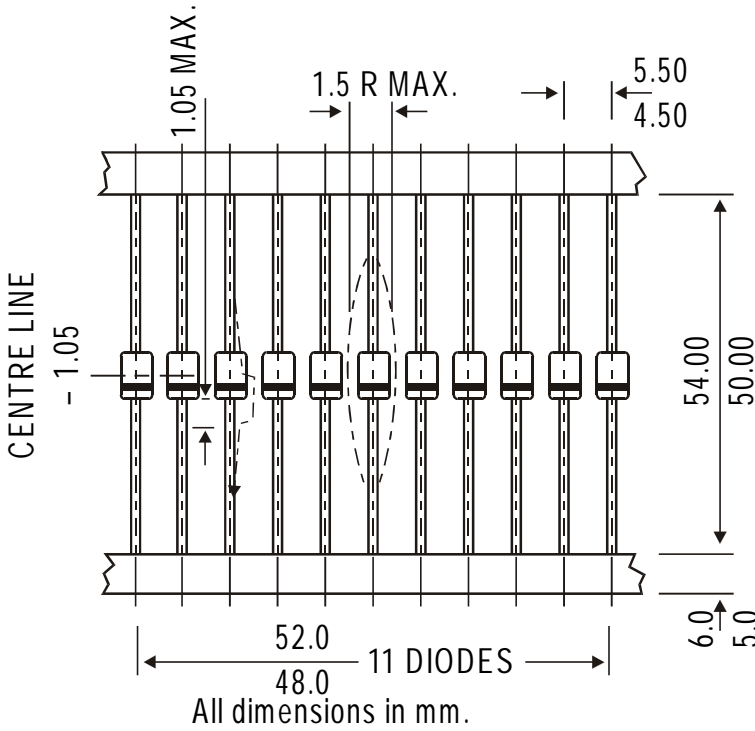

52 mm Taping Specification

1. T & A indicates Axial Tape & Ammo packing (52 mm Tape Spacing).
2. 300 mm (min) leader tape on every spool.
3. No. of empty places allowed 0.25% without consecutive empty places.
4. Ends of leads shall preferably not protrude beyond the tapes.
5. Components shall be held sufficiently in the tape or tapes so that they can not come free in normal handling.

DO-41 AMMO PACK

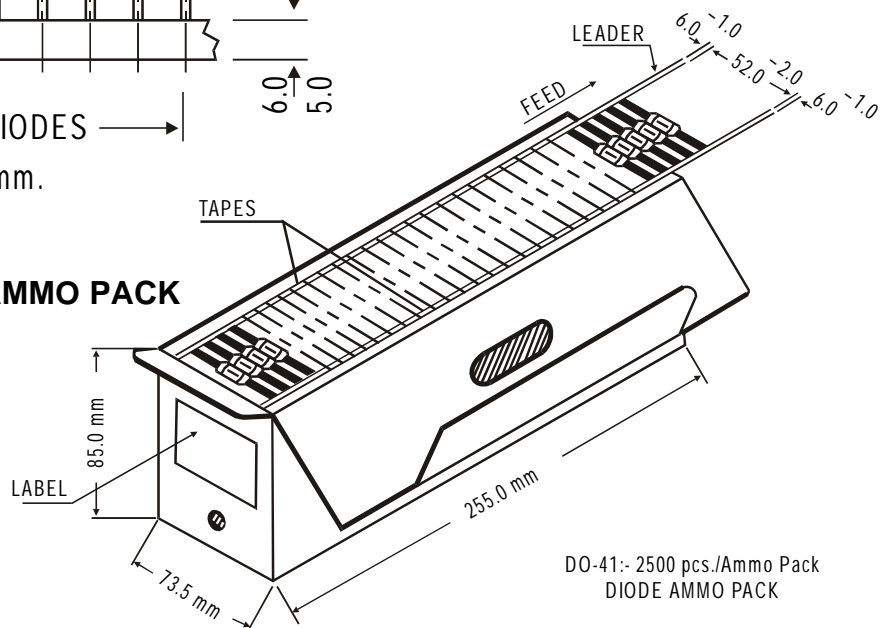

DO-41: 2500 pcs./Ammo Pack
DIODE AMMO PACK

On request also available in 26 mm Tape and Ammo Pack

Packing Detail

PACKAGE	STANDARD PACK		INNER CARTON BOX		OUTER CARTON BOX		
	Details	Net Weight/Qty	Size	Qty	Size	Qty	Gr Wt
DO-41 T&A	2.5K/ammo box	1.04 kg/2.5K pcs	10" x 3.5" x 3.5"	2.5K	12.7" x 12.7" x 20"	62.5K	30 kgs