

<u>BUMPS</u>	<u>PITCH</u>	<u>SIZE</u>	<u>MATRIX</u>	<u>ROWS</u>	<u>CENTER</u>	<u>MAT'L</u>
6	0.5mm	1.5 x 1.0mm	2 x 3	full	na	Wafer Level Si

BALL VIEW

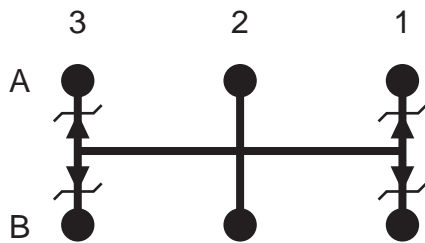

BOTTOM SIDE (TOP X-RAY VIEW)

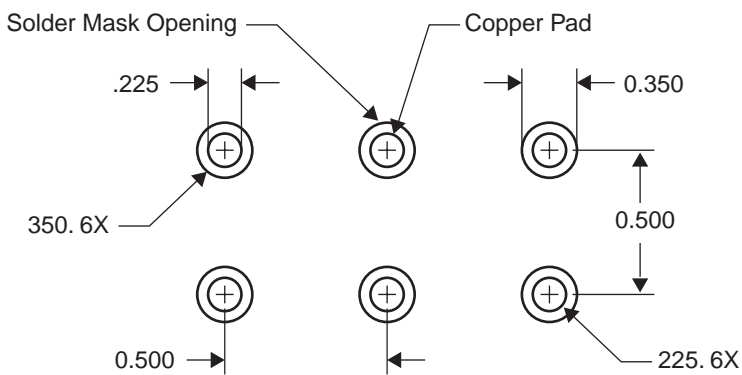
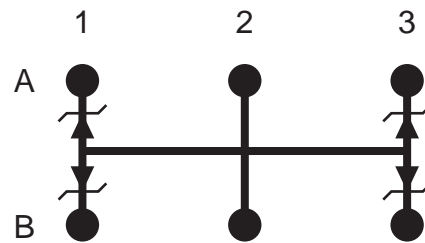

TEST VEHICLE BOARD

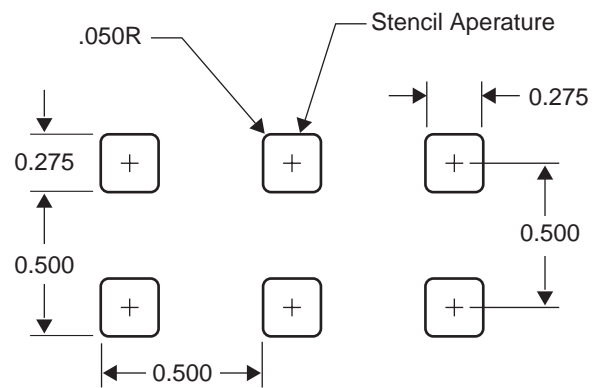

RECOMMENDED STENCIL

FC6P1.5x1.0E500-DC



<u>BUMPS</u>	<u>PITCH</u>	<u>SIZE</u>	<u>MATRIX</u>	<u>ROWS</u>	<u>CENTER</u>	<u>MAT'L</u>	TEL 1-714-898-3830
6	0.5mm	1.5 x 1.0mm	2 x 3	full	na	Wafer Level Si	info@topline.tv

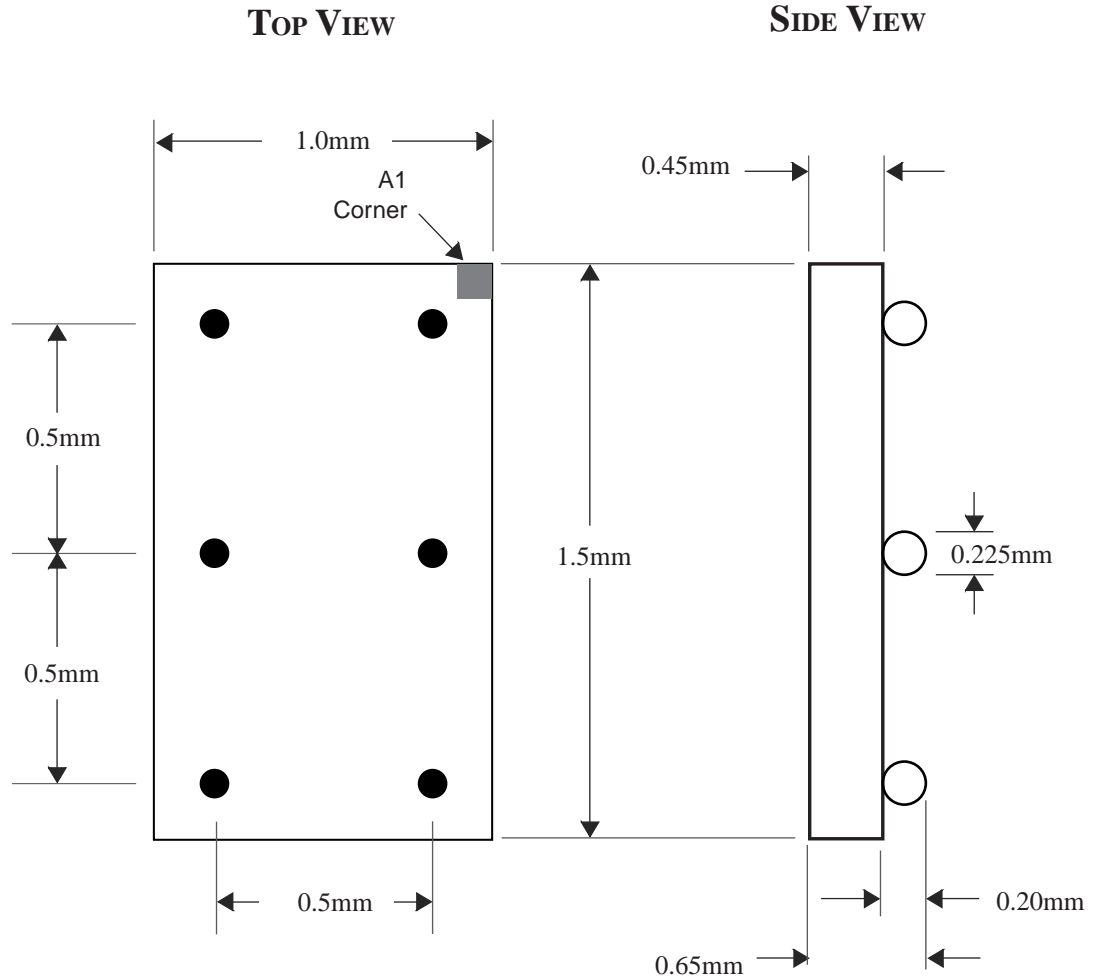

NOTES		REVISIONS		
Note 1	Top marked F45U	Rev	Date	Changes
Note 2	Ball A1 locator mark positioned in corner			
Note 3	Ball Material: 63/37 SnPb			
Note 4	Substrate Material: Si			
Note 5	Alt PN CSP6E7A.5-DC023			
		PACKAGING TRAYS		
		Reel Package, Plastic Tape W=8mm, pitch= 2mm Reel Quantity: 6000, 3000, 1000, 500		