

TOP VIEW

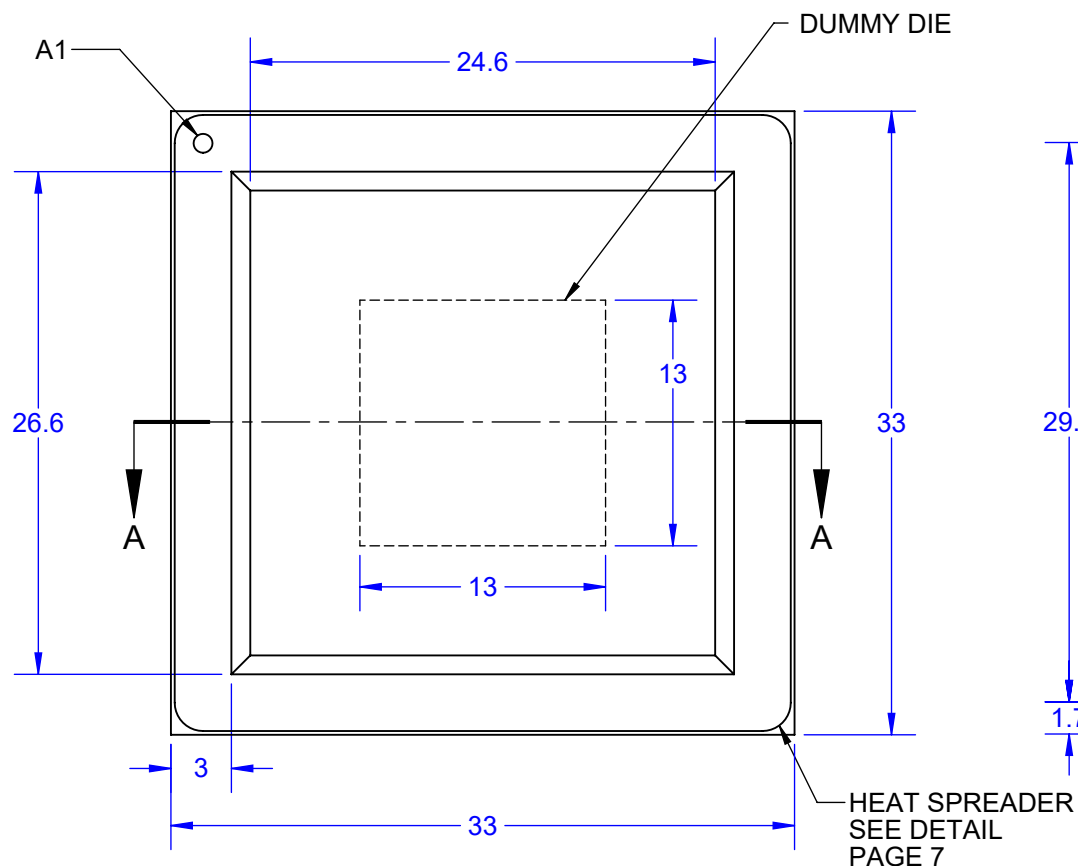

BALL VIEW

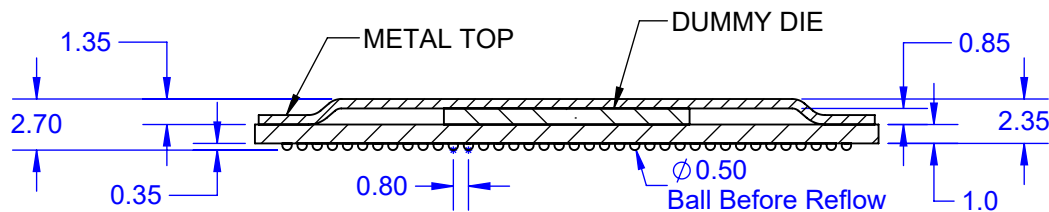
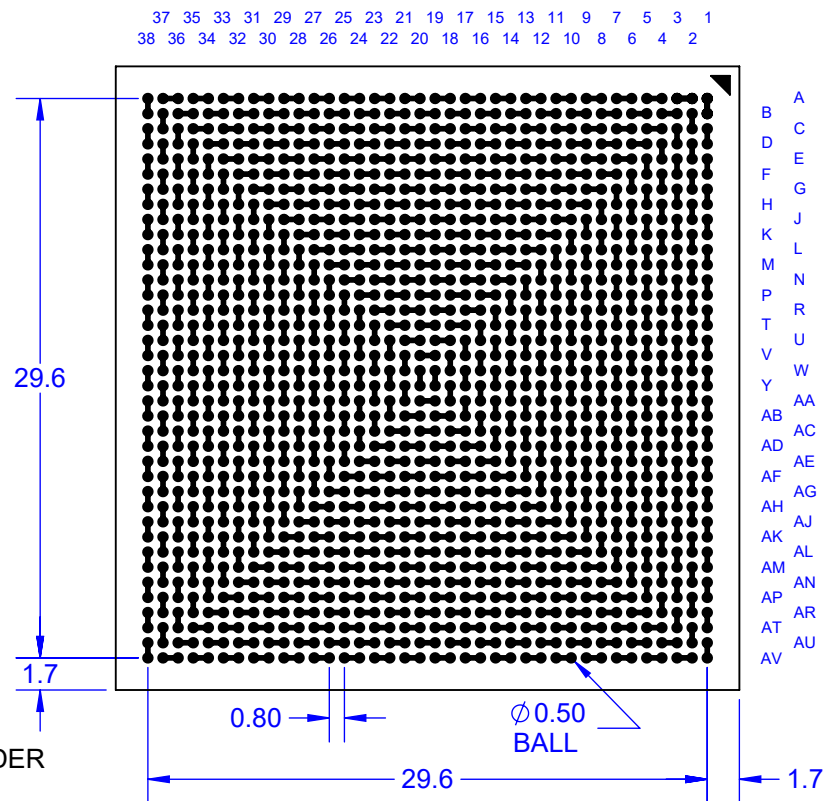

SECTION A-A

Notes: (Unless Otherwise Specified).

- 1) ALL DIMENSIONS ARE IN MM.
- 2) SOLDER BALL ALLOY: SEE PART NUMBER TABLE.
- 3) BALL DIAMETER (BEFORE REFLOW) 0.50mm [20 MIL].
- 4) SOLDER MASK DEFINED PAD OPENING: 0.40mm [16 MIL].
- 5) PAD Cu DIAMETER: 0.508mm [20 MIL].
- 6) SUBSTRATE MATERIAL: BT.
- 7) DUMMY DIE: Si (SILICON).
- 8) DAISY CHAIN PATTERN (SEE PAGE 2).
- 9) MSL-3 RECOMMENDED BAKING 24 HOURS @ 125°C TO REMOVE MOISTURE PRIOR TO SOLDERING TO PC BOARD.

PART NUMBER TABLE

PART NUMBER	BALL METAL	BALL ALLOY	RoHS	Si DIE
SBGA1444T.8C-DC389D	Sn96.5/Ag3.0/Cu0.5	SAC305	YES	YES
SBGA1444T.8-DC389D	Sn63/Pb37	Sn63	NO	YES

APPROVALS	DATE	TopLine®			
DRAWN T. Au	5/29/2025				
ENG M. Hart	5/29/2025	TITLE SBGA1444T.8C-DC389D DAISY CHAIN DUMMY			
MFG		SCALE	SIZE	DRAWING NO.	REV
QA		2.5:1	A	583895	B
CUST		DO NOT SCALE DRAWING			SHEET 1 OF 9
REVISED					

BALL VIEW

37 35 33 31 29 27 25 23 21 19 17 15 13 11 9 7 5 3 1
38 36 34 32 30 28 26 24 22 20 18 16 14 12 10 8 6 4 2

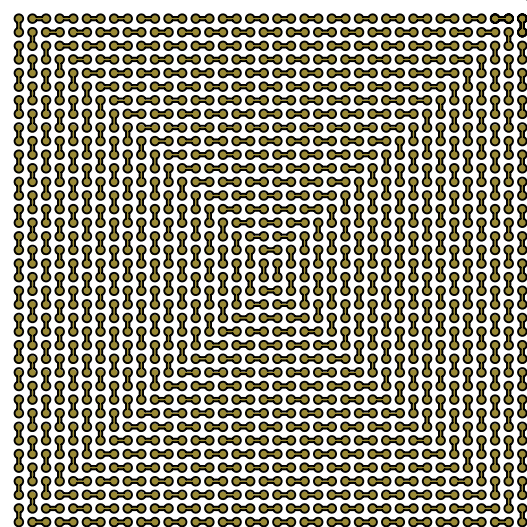

A
B
C
D
E
F
G
H
J
K
L
M
N
P
R
T
U
V
W
Y
AA
AB
AC
AD
AE
AF
AG
AH
AJ
AK
AL
AM
AN
AP
AR
AT
AU
AV

BOTTOM SIDE (TOP X-RAY VIEW)

1 3 5 7 9 11 13 15 17 19 21 23 25 27 29 31 33 35 37
2 4 6 8 10 12 14 16 18 20 22 24 26 28 30 32 34 36 38

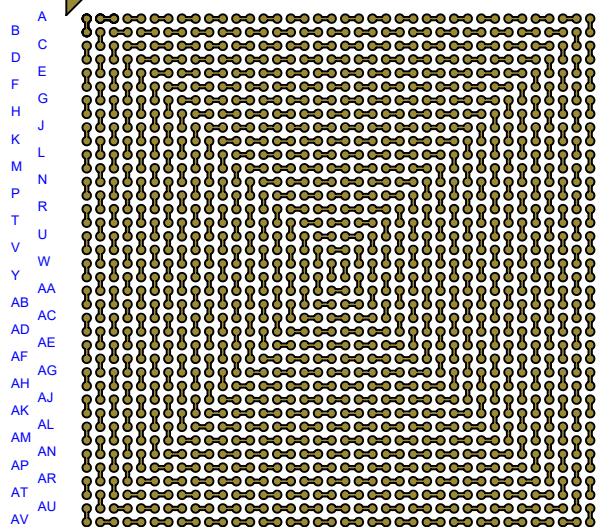

A
B
C
D
E
F
G
H
J
K
L
M
N
P
R
T
U
V
W
Y
AA
AB
AC
AD
AE
AF
AG
AH
AJ
AK
AL
AM
AN
AP
AR
AT
AU
AV

T+ T-

1 3 5 7 9 11 13 15 17 19 21 23 25 27 29 31 33 35 37
2 4 6 8 10 12 14 16 18 20 22 24 26 28 30 32 34 36 38

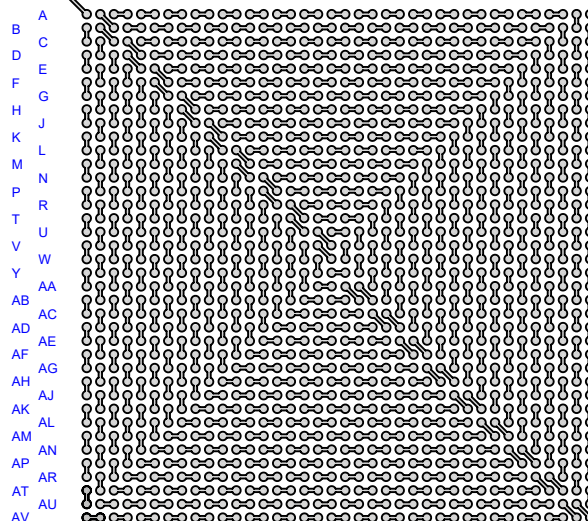

A
B
C
D
E
F
G
H
J
K
L
M
N
P
R
T
U
V
W
Y
AA
AB
AC
AD
AE
AF
AG
AH
AJ
AK
AL
AM
AN
AP
AR
AT
AU
AV

TEST VEHICLE BOARD

T+ T-

1 3 5 7 9 11 13 15 17 19 21 23 25 27 29 31 33 35 37
2 4 6 8 10 12 14 16 18 20 22 24 26 28 30 32 34 36 38

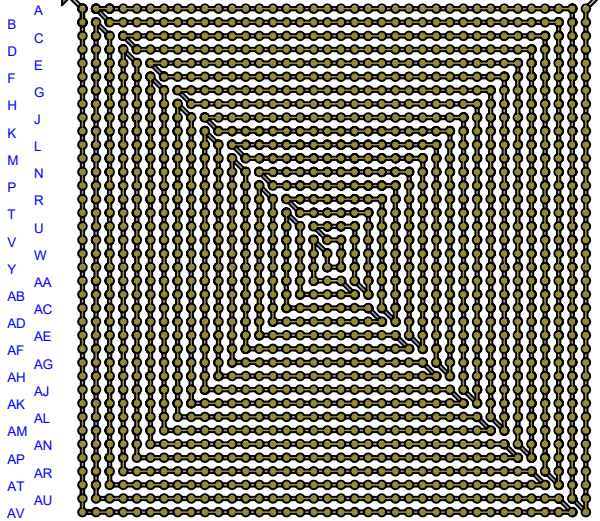

A
B
C
D
E
F
G
H
J
K
L
M
N
P
R
T
U
V
W
Y
AA
AB
AC
AD
AE
AF
AG
AH
AJ
AK
AL
AM
AN
AP
AR
AT
AU
AV

AFTER MOUNTING

Notes: (Unless Otherwise Specified).

- 1) PCB BOARD DIMENSIONS ARE PRESENTED ONLY AS A GUIDELINE DESIGNERS SHOULD USE THEIR OWN KNOWLEDGE WHEN DESIGNING THE PCB.
- 2) PCB Cu BALL PAD DIAMETER: 0.508mm [20 MIL].
- 3) PCB DAISY CHAIN TRACING LINE WIDTH: 0.20mm [8 MIL].
- 4) SMD (SOLDERMASK DEFINED) PAD OPENING: 0.40mm [16 MIL].



TITLE			
SBGA1444T.8C-DC389D DAISY CHAIN DUMMY			
SCALE	SIZE	DRAWING NO.	REV
5:2	A	583895	B
DO NOT SCALE DRAWING			SHEET 2 OF 9

BALL VIEW

37 35 33 31 29 27 25 23 21 19 17 15 13 11 9 7 5 3 1
 38 36 34 32 30 28 26 24 22 20 18 16 14 12 10 8 6 4 2

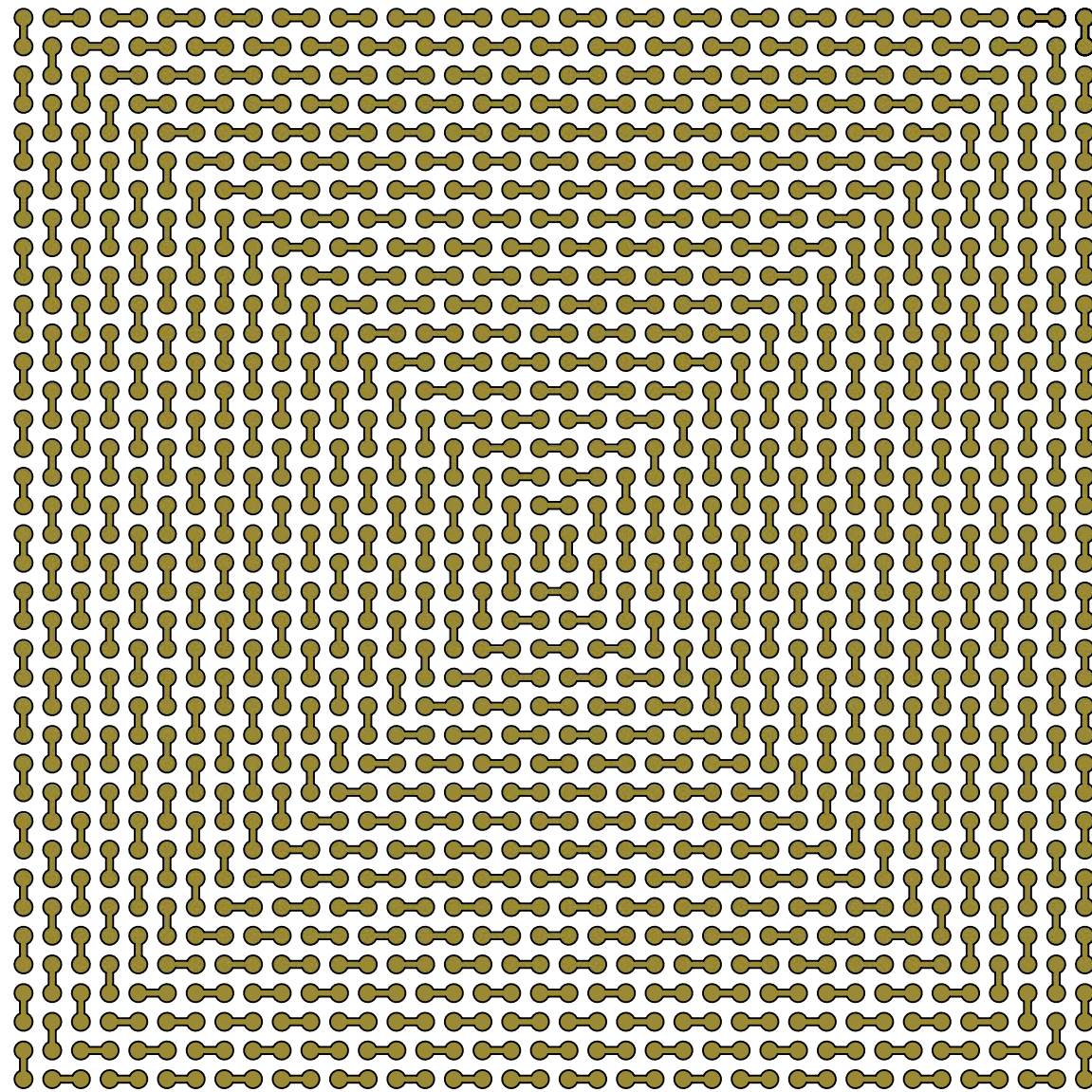

A
 B
 C
 D
 E
 F
 G
 H
 J
 K
 L
 M
 N
 P
 R
 T
 U
 V
 W
 Y
 AA
 AB
 AC
 AD
 AE
 AF
 AG
 AH
 AJ
 AK
 AL
 AM
 AN
 AP
 AR
 AT
 AU
 AV

TopLine®			
TITLE		SBGA1444T.8C-DC389D DAISY CHAIN DUMMY	
SCALE	SIZE	DRAWING NO.	REV
5:1	A	583895	B
DO NOT SCALE DRAWING			SHEET 3 OF 9

BOTTOM SIDE (TOP X-RAY VIEW)

1 3 5 7 9 11 13 15 17 19 21 23 25 27 29 31 33 35 37
 2 4 6 8 10 12 14 16 18 20 22 24 26 28 30 32 34 36 38

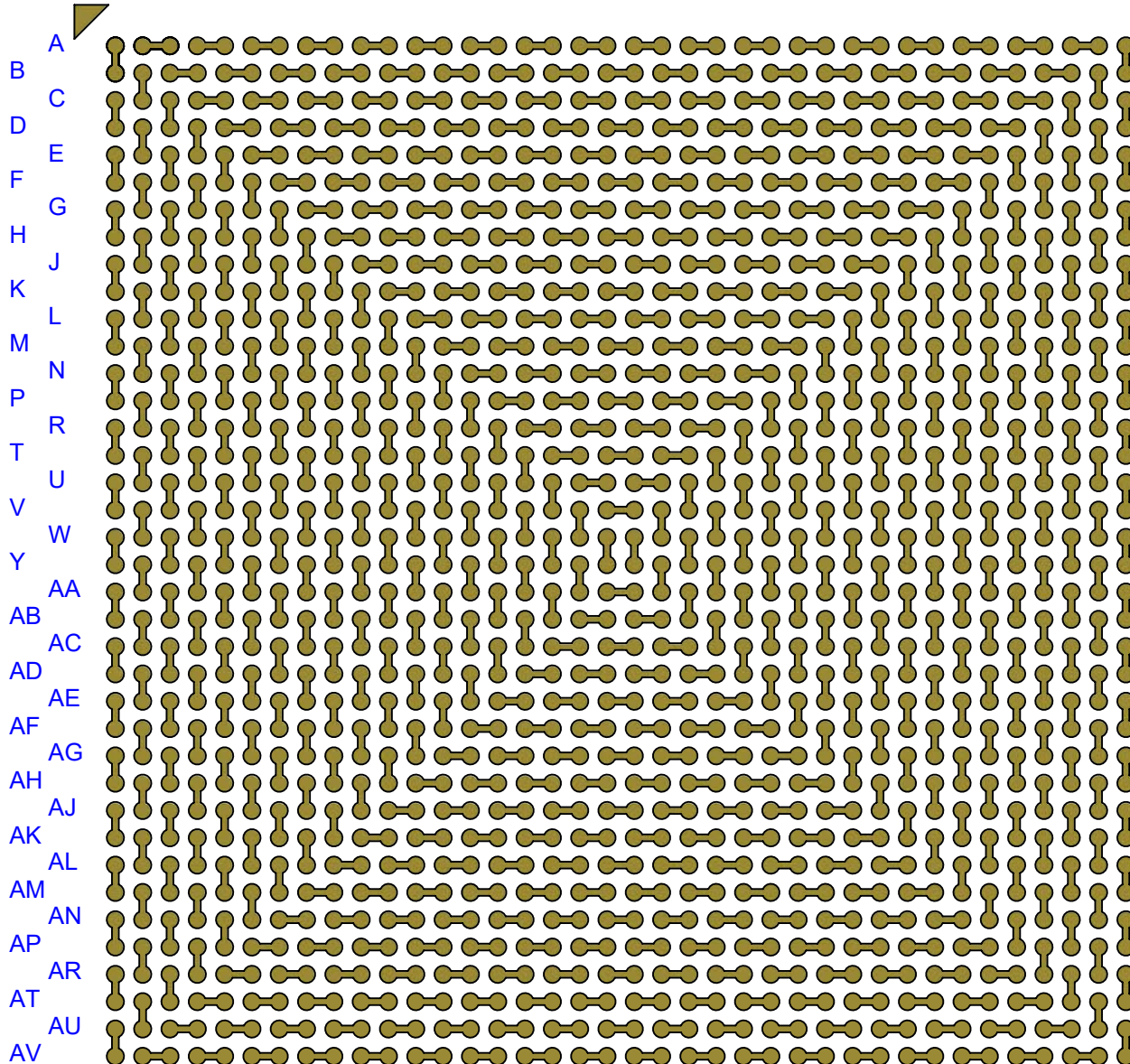

TopLine®

TITLE SBGA1444T.8C-DC389D
 DAISY CHAIN DUMMY

SCALE 5:1	SIZE A	DRAWING NO. 583895	REV B
--------------	-----------	-----------------------	----------

TEST VEHICLE BOARD

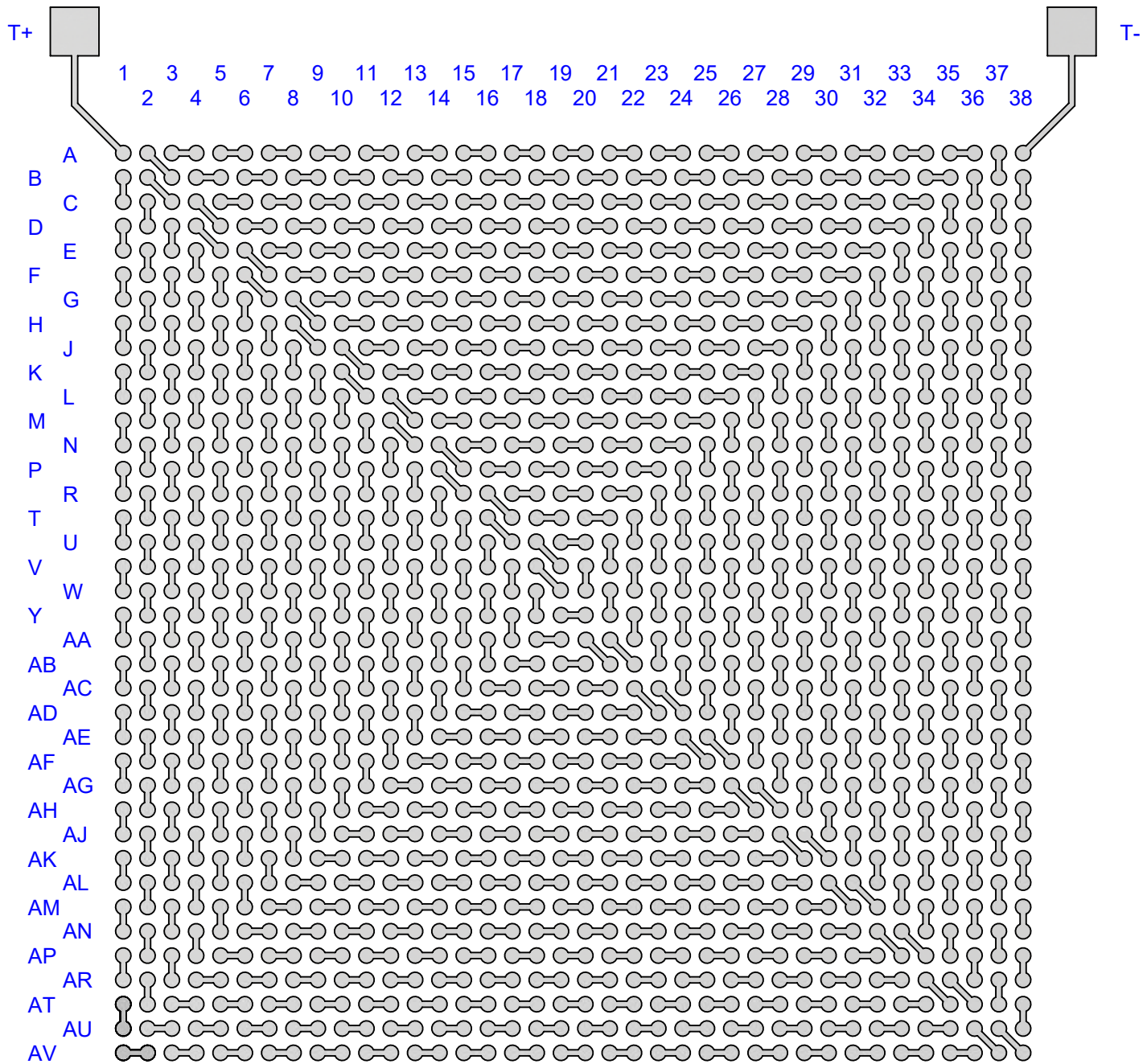

TopLine[®]			
TITLE SBGA1444T.8C-DC389D DAISY CHAIN DUMMY			
SCALE 5:1	SIZE A	DRAWING NO. 583895	REV B
DO NOT SCALE DRAWING			SHEET 5 OF 9

AFTER MOUNTING TO TEST BOARD

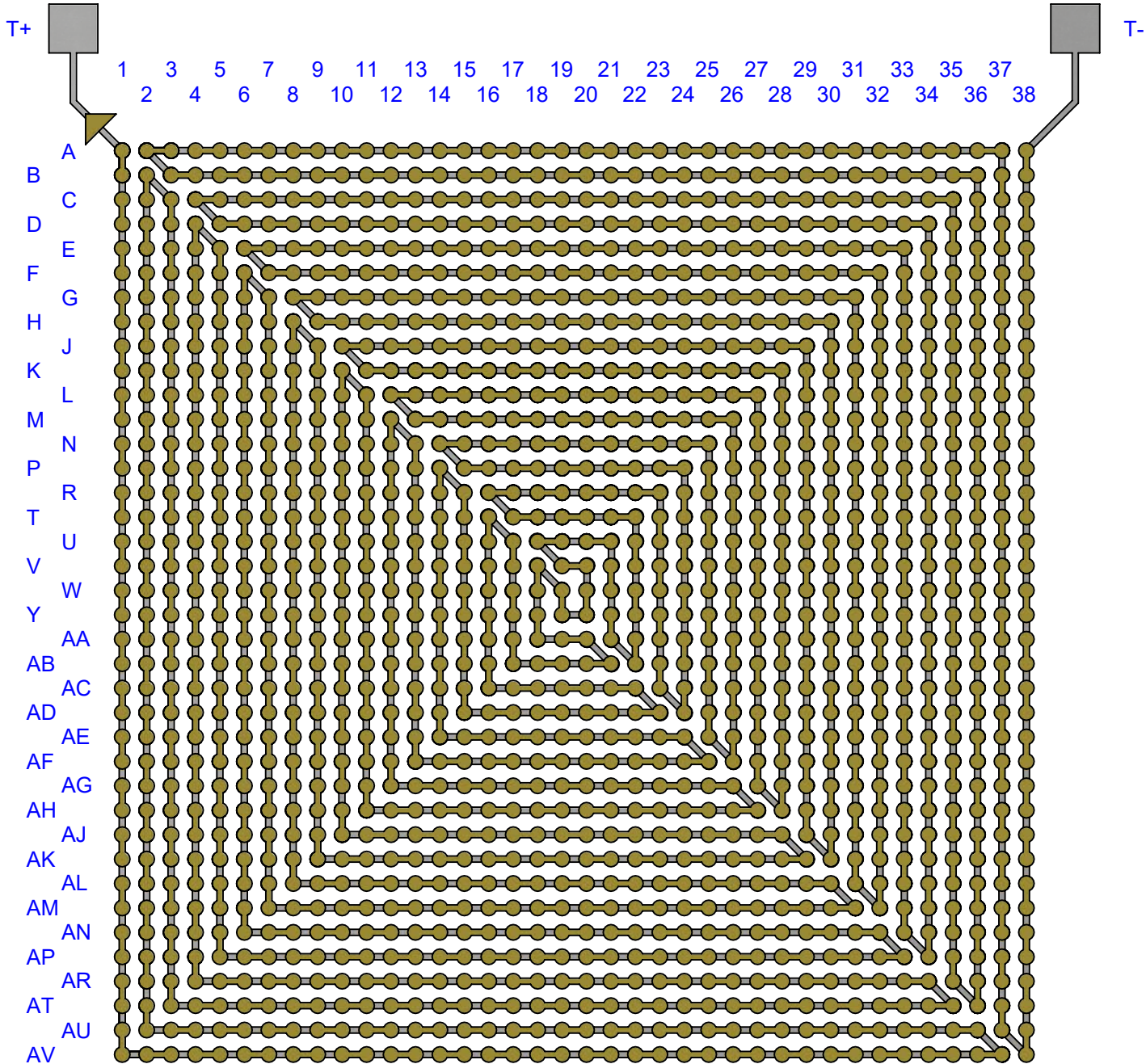

TopLine[®]			
TITLE SBGA1444T.8C-DC389D DAISY CHAIN DUMMY			
SCALE 5:1	SIZE A	DRAWING NO. 583895	REV B
DO NOT SCALE DRAWING		SHEET 6 OF 9	

HEAT SPREADER

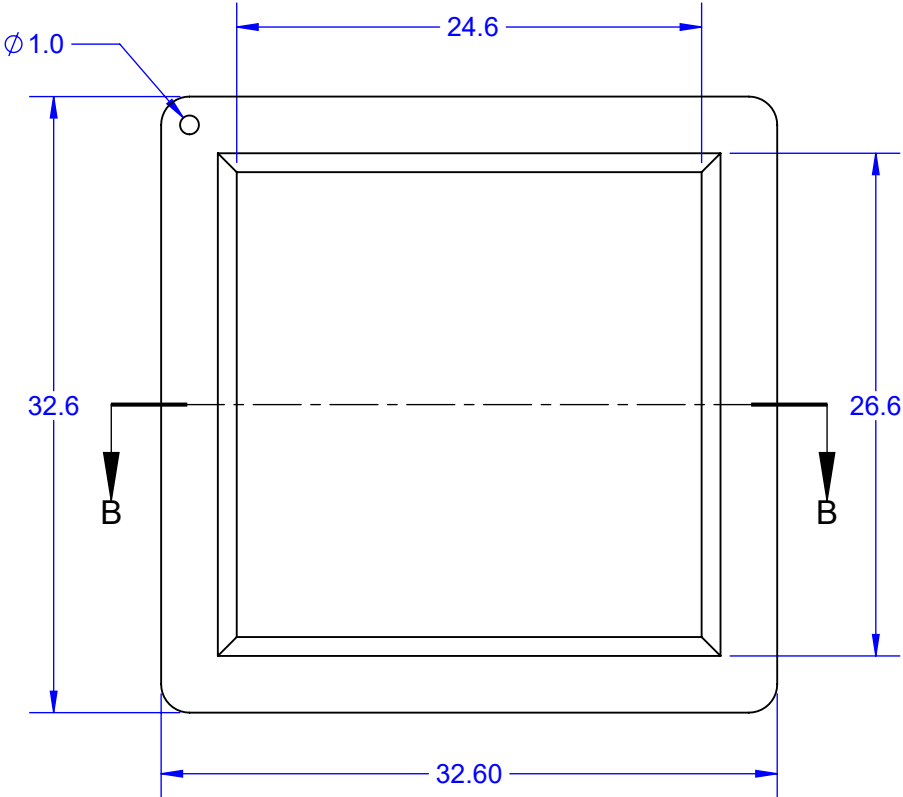

TOP

MODEL



CAVITY

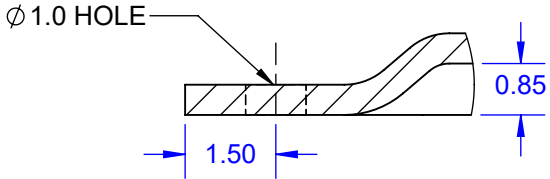

DETAIL E
SCALE 8 : 1

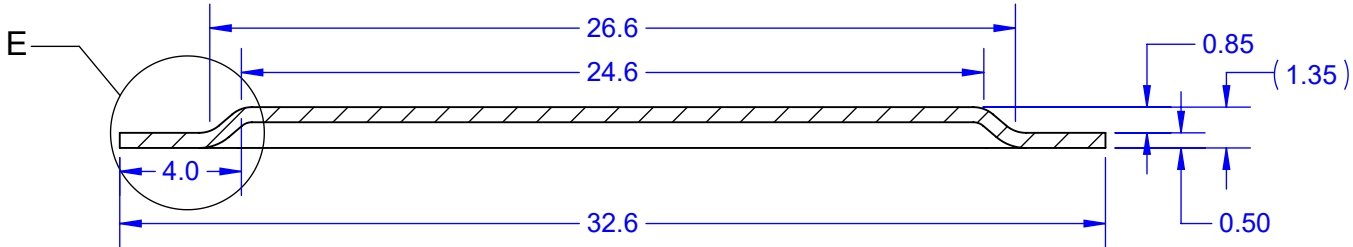

SECTION B-B
SCALE 4 : 1

* ADD 0.13MM SEALANT

TopLine®			
TITLE SBGA1444T.8C-DC389D DAISY CHAIN DUMMY			
SCALE 2.5:1	SIZE A	DRAWING NO. 583895	REV B
DO NOT SCALE DRAWING			SHEET 7 OF 9

MODEL

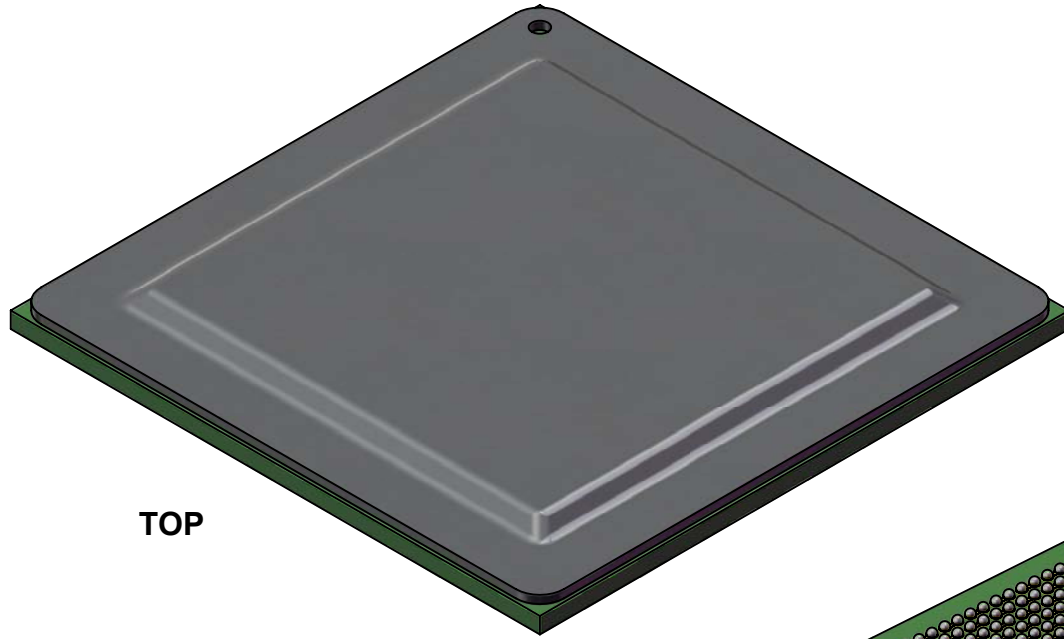

TOP

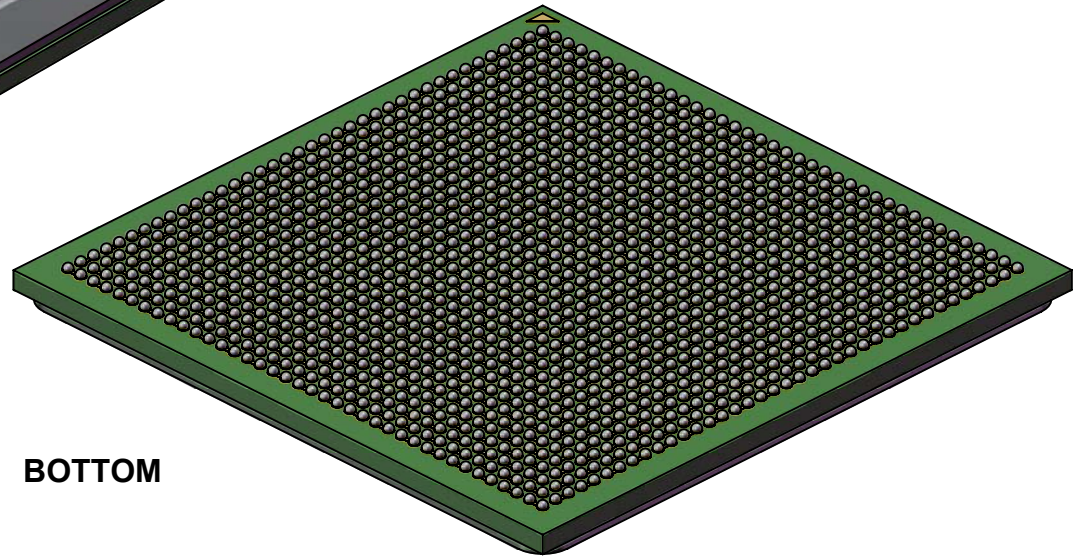

BOTTOM

TopLine[®]

TITLE SBGA1444T.8C-DC389D
DAISY CHAIN DUMMY

SCALE 3:1	SIZE A	DRAWING NO. 583895	REV B
--------------	-----------	-----------------------	----------

DO NOT SCALE DRAWING

SHEET 8 OF 9

BOTTOM SOLDER MASK (RIGHT READING)

37 35 33 31 29 27 25 23 21 19 17 15 13 11 9 7 5 3 1
38 36 34 32 30 28 26 24 22 20 18 16 14 12 10 8 6 4 2

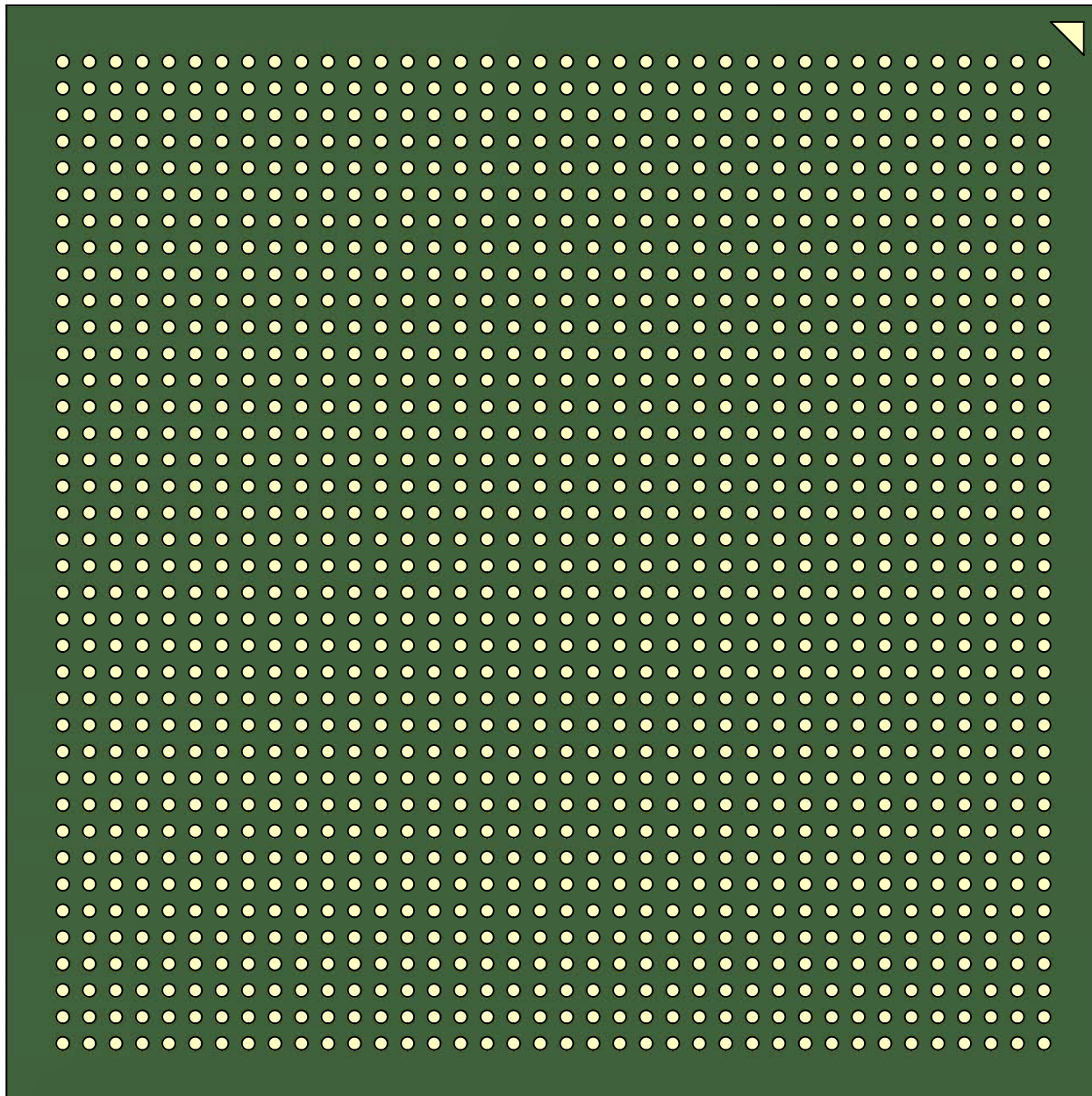

A
B
C
D
E
F
G
H
J
K
L
M
N
P
R
T
U
V
W
Y
AA
AB
AC
AD
AE
AF
AG
AH
AJ
AK
AL
AM
AN
AP
AR
AT
AU
AV

TopLine[®]			
TITLE SBGA1444T.8C-DC389D DAISY CHAIN DUMMY			
SCALE 5:1	SIZE A	DRAWING NO. 583895	REV B
DO NOT SCALE DRAWING			SHEET 9 OF 9