

### TOP VIEW

DUMMY DIE

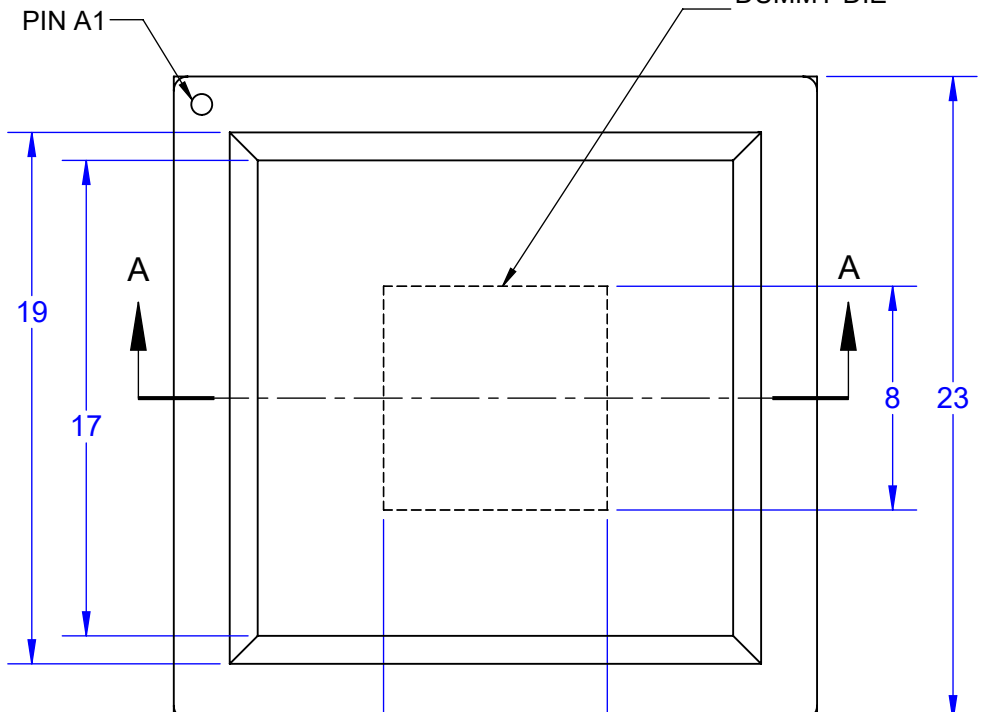

### BALL VIEW

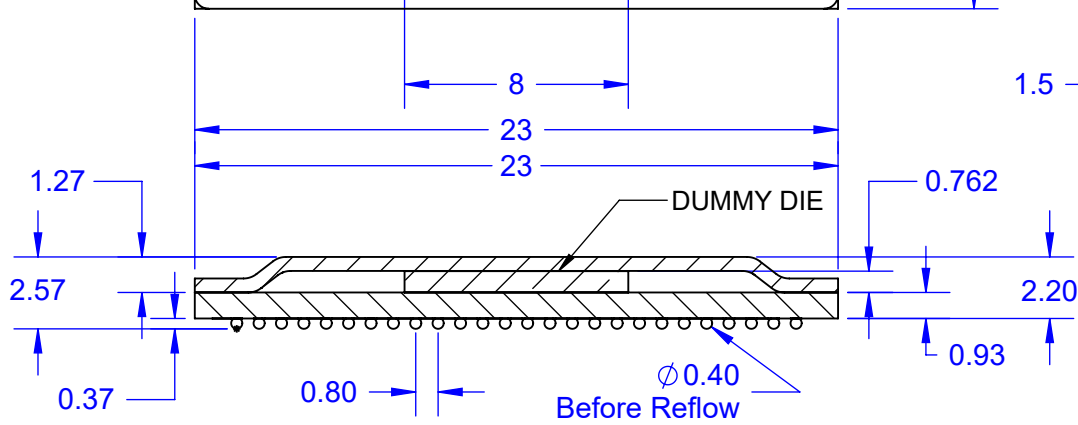
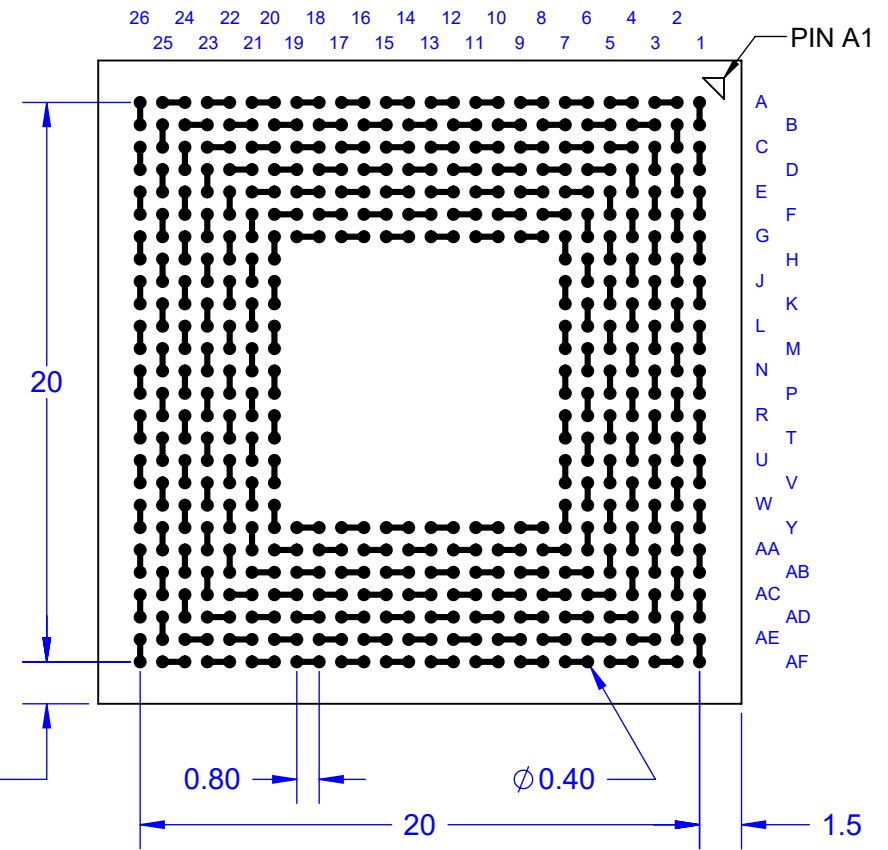

### SECTION A-A

Notes: (Unless Otherwise Specified).

- 1) ALL DIMENSIONS ARE IN MM.
- 2) SOLDER BALL ALLOY: SEE PART NUMBER TABLE.
- 3) BALL DIAMETER (BEFORE REFLOW): 0.40mm.
- 4) SOLDER MASK DEFINED PAD OPENING: 0.33mm (13 MIL).
- 5) PAD Cu DIAMETER: 0.508mm (20 MIL).
- 6) SUBSTRATE MATERIAL: BT.
- 7) DUMMY DIE IS OPTIONAL.
- 8) DAISY CHAIN PATTERN (SEE PAGE 2).
- 9) MSL-3 RECOMMENDED BAKING 24 HOURS @ 125°C TO REMOVE MOISTURE PRIOR SOLDERING TO PC BOARD.

PART NUMBER TABLE				
PART NUMBER	BALL ALLOY	BALL CODE	RoHS	Si DIE
SBGA532T.8C-DC266D	Sn96.5/Ag3.0/Cu0.5	SAC305	YES	YES
SBGA532T.8-DC266D	Sn63/Pb37	Sn63	NO	YES

APPROVALS	DATE	<b>TopLine®</b>			
DRAWN T.Au	5/26/2025				
ENG M. Hart	5/26/2025	TITLE SBGA532T.8C-DC266D DAISY CHAIN DUMMY			
MFG		SCALE 3.7:1	SIZE A	DRAWING NO. 582666	REV B
QA		DO NOT SCALE DRAWING			SHEET 1 OF 5
CUST					
REVISED					

### BALL VIEW

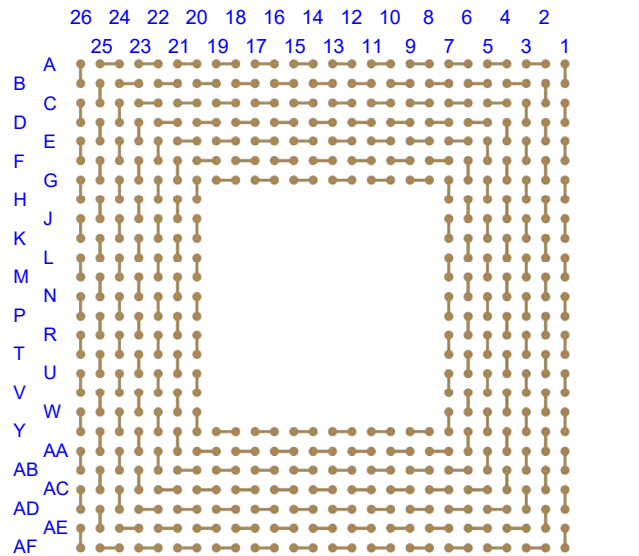

### BOTTOM SIDE (TOP X-RAY VIEW)

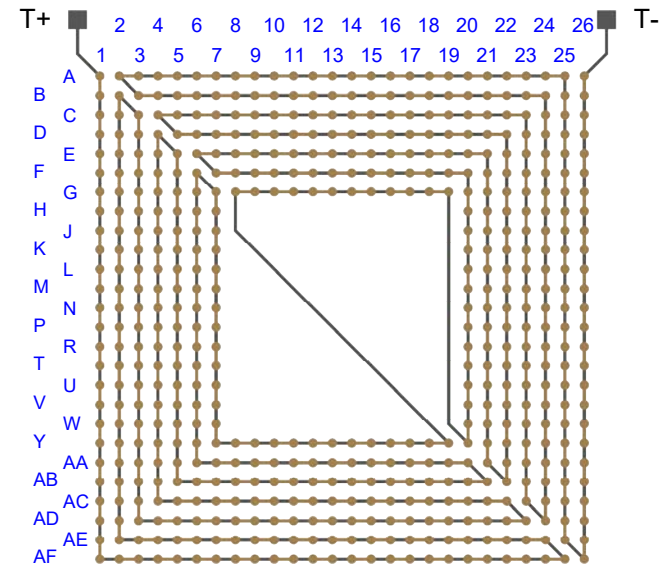
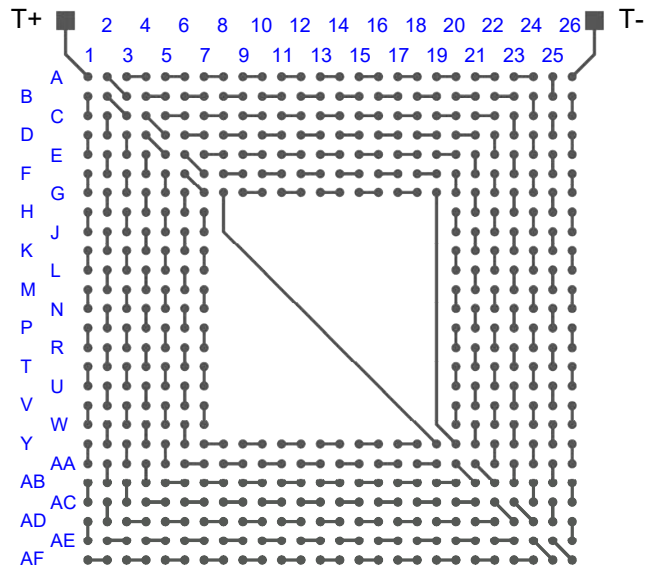
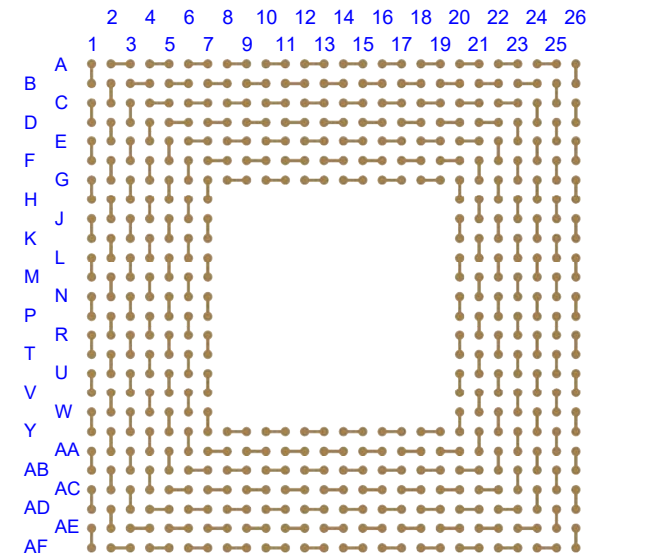

**TEST VEHICLE BOARD**

**AFTER MOUNTING**

**Notes:**

- 1) PCB BOARD DIMENSIONS ARE PRESENTED ONLY AS A GUIDELINE. DESIGNERS SHOULD USE THEIR OWN EXPERIENCE WHEN DESIGNING PCB.
- 2) PCB Cu BALL PAD DIAMETER 0.508mm (20 MIL).
- 3) PCB DAISY CHAIN TRACING LINE WIDTH 0.152mm (6 MIL).
- 4) SMD (SOLDER MASK DEFINED) PAD OPENING: 0.33mm (13 MIL).

<b>TopLine®</b>			
TITLE		SBGA532T.8C-DC266D DAISY CHAIN DUMMY	
SCALE	SIZE	DRAWING NO.	REV
3:1	A	582666	B
DO NOT SCALE DRAWING			SHEET 2 OF 5

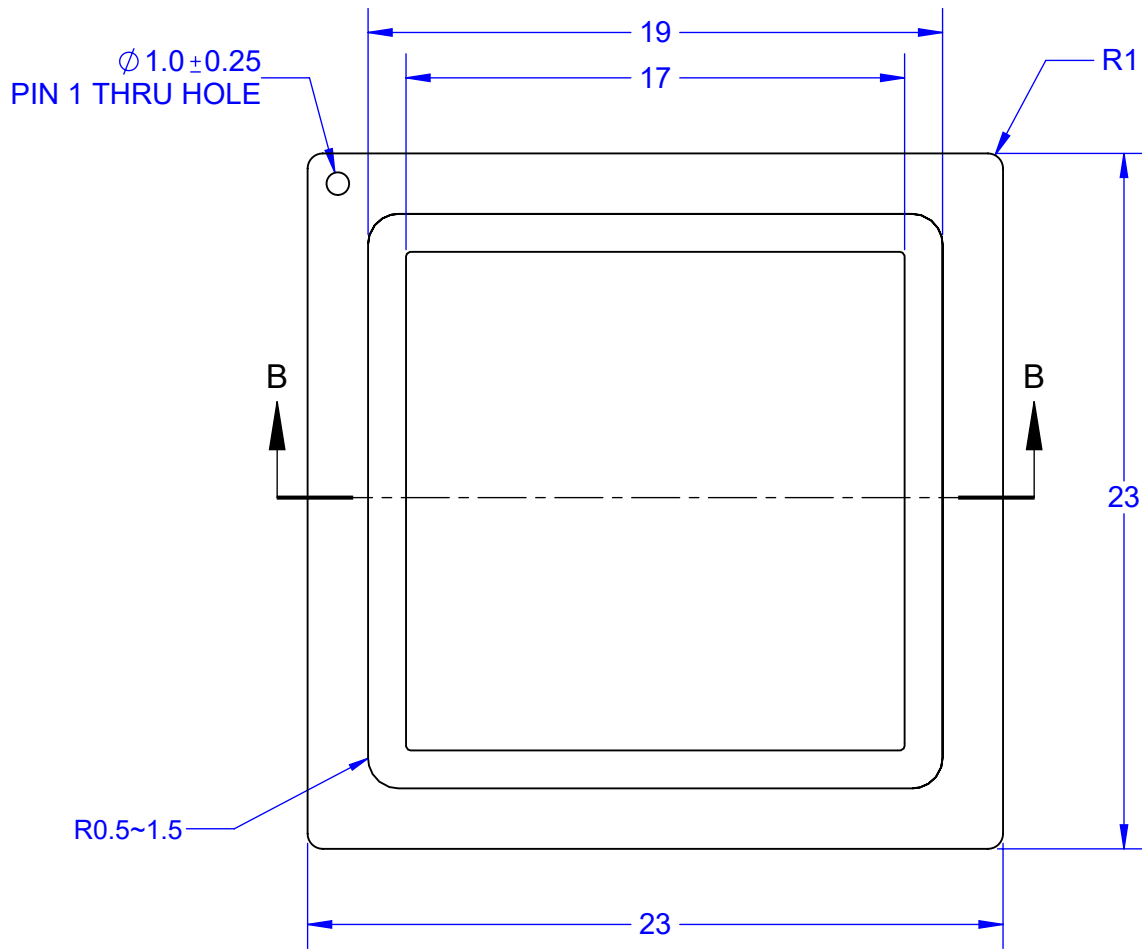

TOP



MODEL

CAVITY

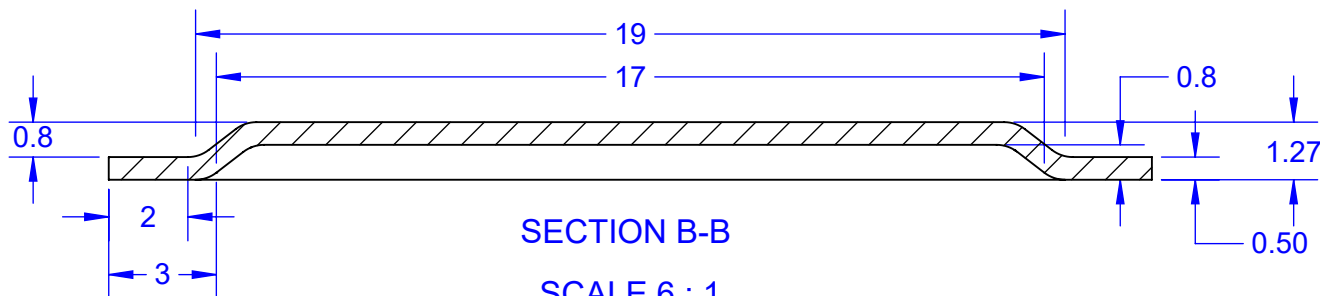

<b>TopLine®</b>			
TITLE SBGA532T.8C-DC266D DAISY CHAIN DUMMY			
SCALE 3:1	SIZE A	DRAWING NO. 582666	REV B
DO NOT SCALE DRAWING			SHEET 3 OF 5

MODEL

TOP

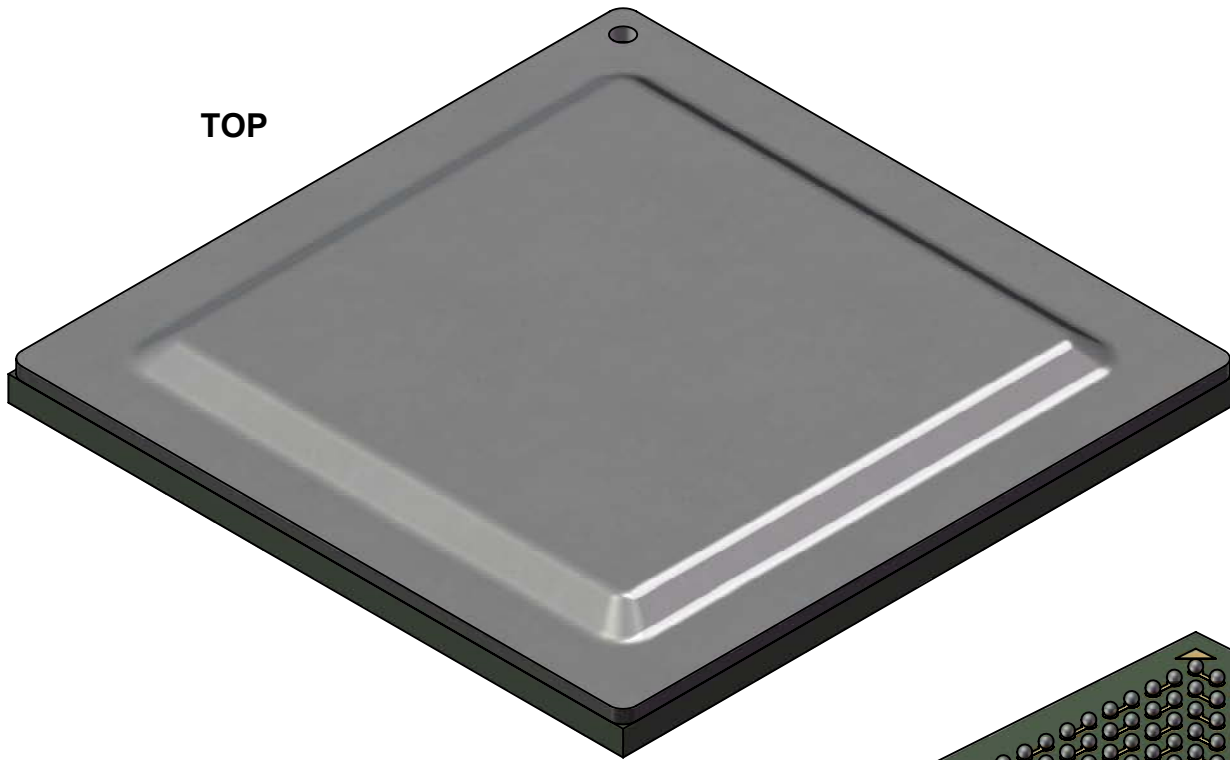

BALL VIEW

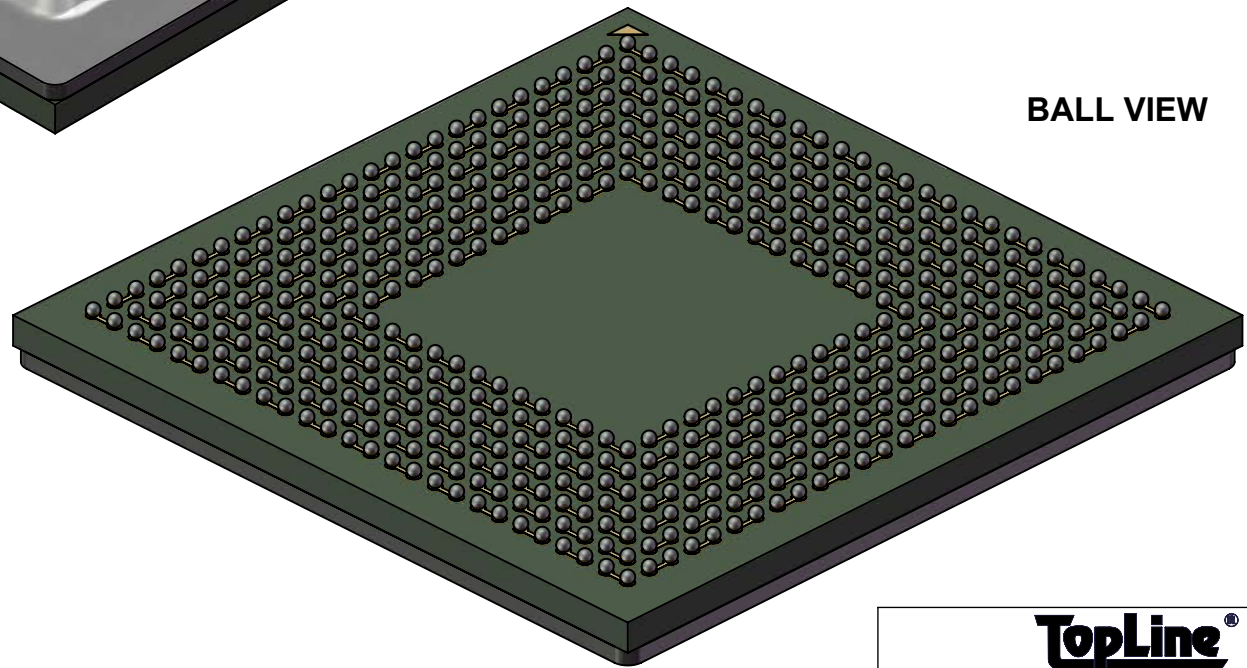

**TopLine**<sup>®</sup>

TITLE SBGA532T.8C-DC266D  
DAISY CHAIN DUMMY

SCALE	SIZE	DRAWING NO.	REV
5:1	A	582666	B

DO NOT SCALE DRAWING

SHEET 4 OF 5

**BOTTOM SOLDER MASK  
(RIGHT READING)**

26 25 24 23 22 21 20 19 18 17 16 15 14 13 12 11 10 9 8 7 6 5 4 3 2 1

A  
B  
C  
D  
E  
F  
G  
H  
J  
K  
L  
M  
N  
P  
R  
T  
U  
V  
W  
Y  
AA  
AB  
AC  
AD  
AE  
AF

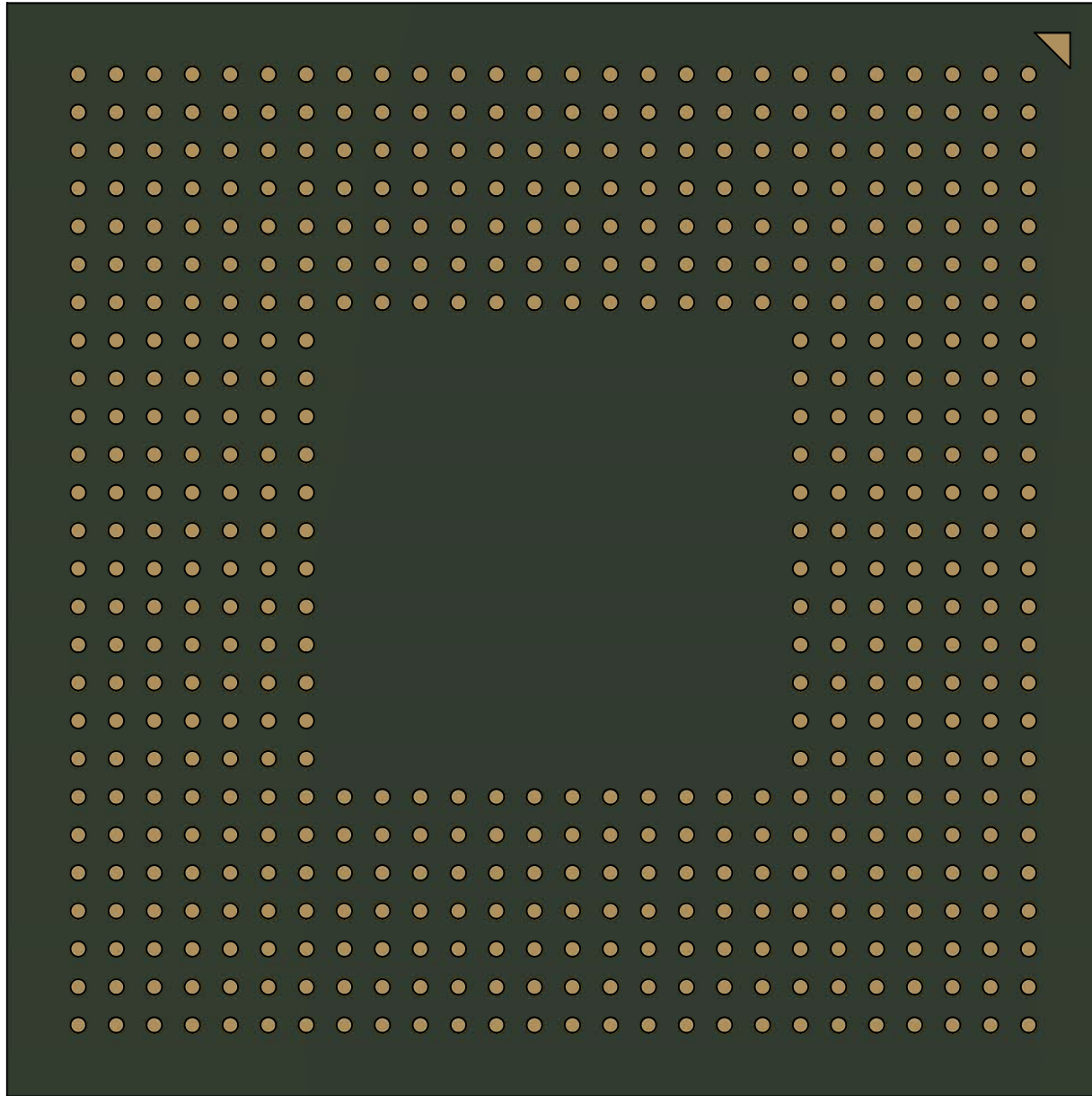

<b>TopLine®</b>			
TITLE BGA532T.8C-DC266D DAISY CHAIN DUMMY			
SCALE 3:1	SIZE A	DRAWING NO. 582666	REV B
DO NOT SCALE DRAWING			SHEET 5 OF 5