

PACKAGE STACK UP

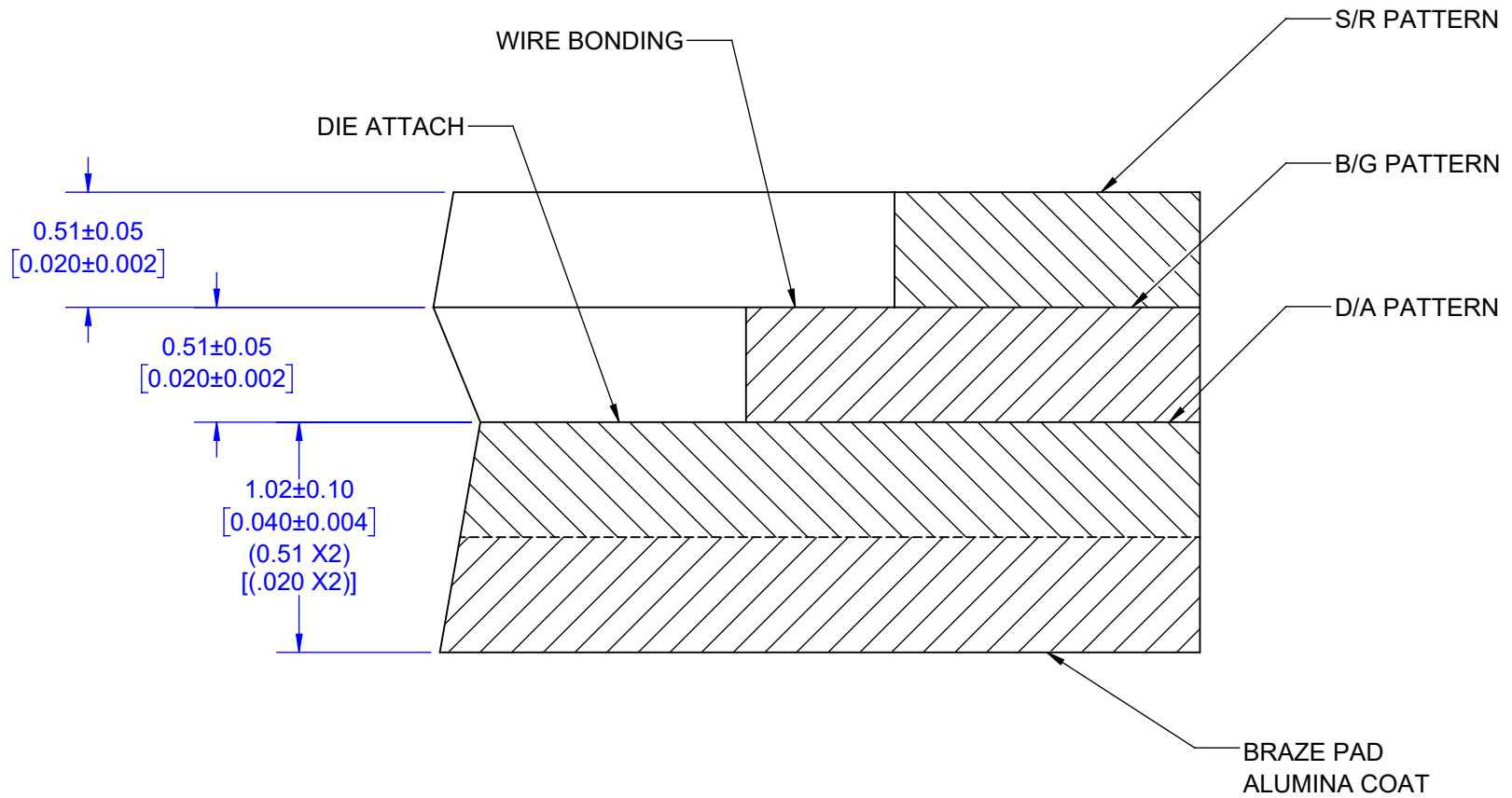

TopLine®

TITLE CPGA121T13x13-N670
CERAMIC PIN GRID ARRAY

| SCALE | SIZE | DRAWING NO. | REV |
|-------|------|-------------|-----|
| 32:1 | A | 168507 | A |

DO NOT SCALE DRAWING

SHEET 2 OF 7

BONDING PADS

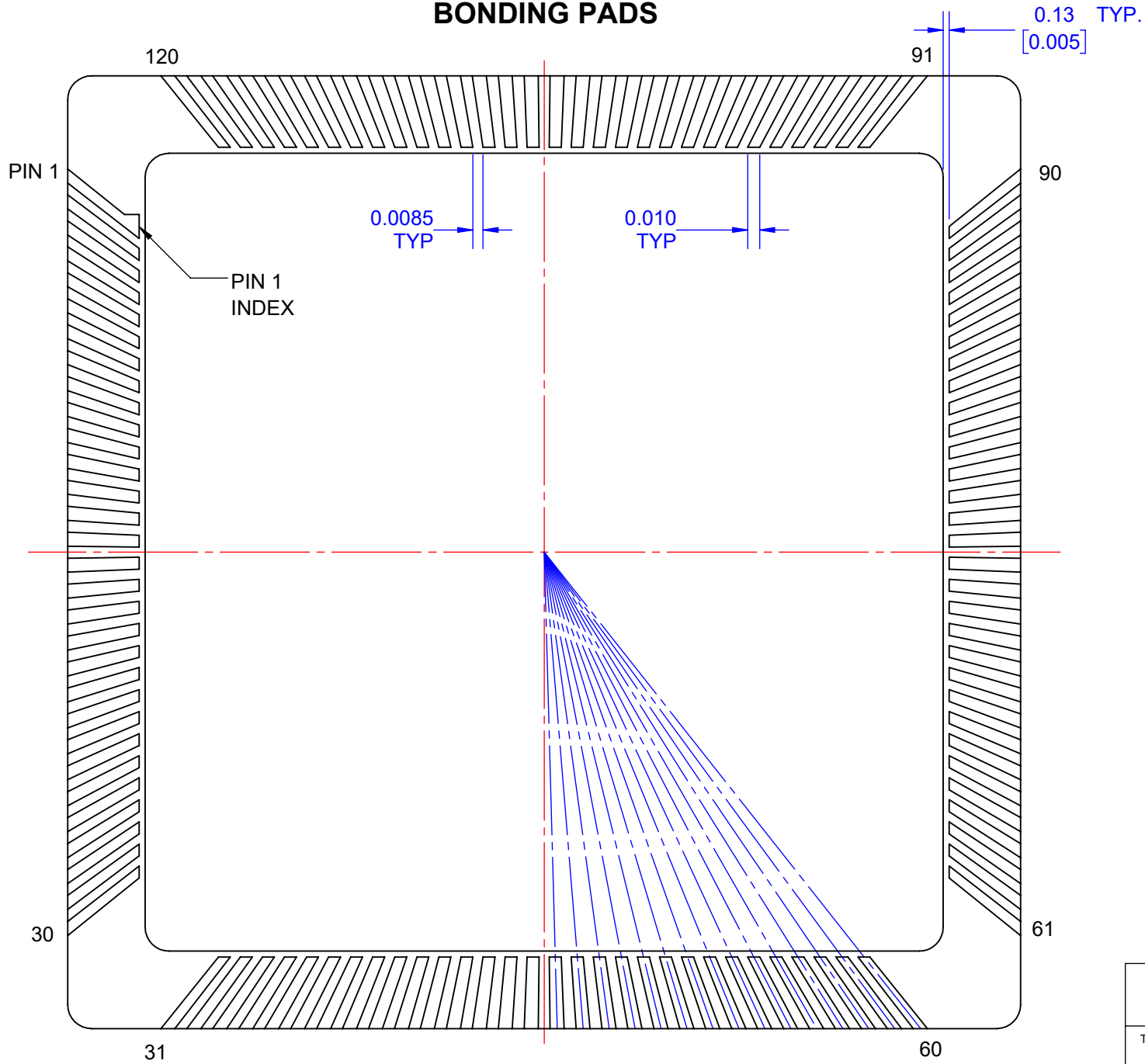

Notes: (Unless Otherwise Specified).
1) DIMENSIONS INCHES.

| | | | |
|--|-----------|-----------------------|----------|
| TopLine® | | | |
| TITLE CPGA121T13x13-N670 CERAMIC PIN GRID ARRAY | | | |
| SCALE 8:1 | SIZE A | DRAWING NO. 168507 | REV A |
| DO NOT SCALE DRAWING | | SHEET 3 OF 7 | |

BOND PAD NET LIST

| BOND | PIN | BOND | PIN | BOND | PIN | BOND | PIN | BOND | PIN |
|------|-----|------|-----|------|-----|------|-----|------|-----|
| 1 | C3 | 26 | L1 | 51 | N9 | 76 | G11 | 101 | A9 |
| 2 | B2 | 27 | M1 | 52 | M9 | 77 | G13 | 102 | C8 |
| 3 | B1 | 28 | K3 | 53 | N10 | 78 | F13 | 103 | B8 |
| 4 | D3 | 29 | L2 | 54 | L9 | 79 | F12 | 104 | A8 |
| 5 | C2 | 30 | N1 | 55 | M10 | 80 | F11 | 105 | B7 |
| 6 | C1 | 31 | L3 | 56 | N11 | 81 | E13 | 106 | C7 |
| 7 | D2 | 32 | M2 | 57 | N12 | 82 | E12 | 107 | A7 |
| 8 | E3 | 33 | N2 | 58 | L10 | 83 | D13 | 108 | A6 |
| 9 | D1 | 34 | L4 | 59 | M11 | 84 | E11 | 109 | B6 |
| 10 | E2 | 35 | M3 | 60 | N13 | 85 | D12 | 110 | C6 |
| 11 | E1 | 36 | N3 | 61 | L11 | 86 | C13 | 111 | A5 |
| 12 | F3 | 37 | M4 | 62 | M12 | 87 | B13 | 112 | B5 |
| 13 | F2 | 38 | L5 | 63 | M13 | 88 | D11 | 113 | A4 |
| 14 | F1 | 39 | N4 | 64 | K11 | 89 | C12 | 114 | C5 |
| 15 | G2 | 40 | M5 | 65 | L12 | 90 | A13 | 115 | B4 |
| 16 | G3 | 41 | N5 | 66 | L13 | 91 | C11 | 116 | A3 |
| 17 | G1 | 42 | L6 | 67 | K12 | 92 | B12 | 117 | A2 |
| 18 | H1 | 43 | M6 | 68 | J11 | 93 | A12 | 118 | C4 |
| 19 | H2 | 44 | N6 | 69 | K13 | 94 | C10 | 119 | B3 |
| 20 | H3 | 45 | M7 | 70 | J12 | 95 | B11 | 120 | A1 |
| 21 | J1 | 46 | L7 | 71 | J13 | 96 | A11 | | |
| 22 | J2 | 47 | N7 | 72 | H11 | 97 | B10 | | |
| 23 | K1 | 48 | N8 | 73 | H12 | 98 | C9 | | |
| 24 | J3 | 49 | M8 | 74 | H13 | 99 | A10 | | |
| 25 | K2 | 50 | L8 | 75 | G12 | 100 | B9 | | |

| BOND | PIN | NOTE |
|------|-----|---------------|
| 121 | D4 | NO CONNECTION |
| S/R | | NO CONNECTION |
| D/A | | NO CONNECTION |

TopLine®

TITLE CPGA121T13x13-N670
CERAMIC PIN GRID ARRAY

| | | | |
|---------------|-----------|-----------------------|----------|
| SCALE NONE | SIZE A | DRAWING NO. 168507 | REV A |
|---------------|-----------|-----------------------|----------|

DO NOT SCALE DRAWING

SHEET 4 OF 7

MODEL
SHOWN WITHOUT LID

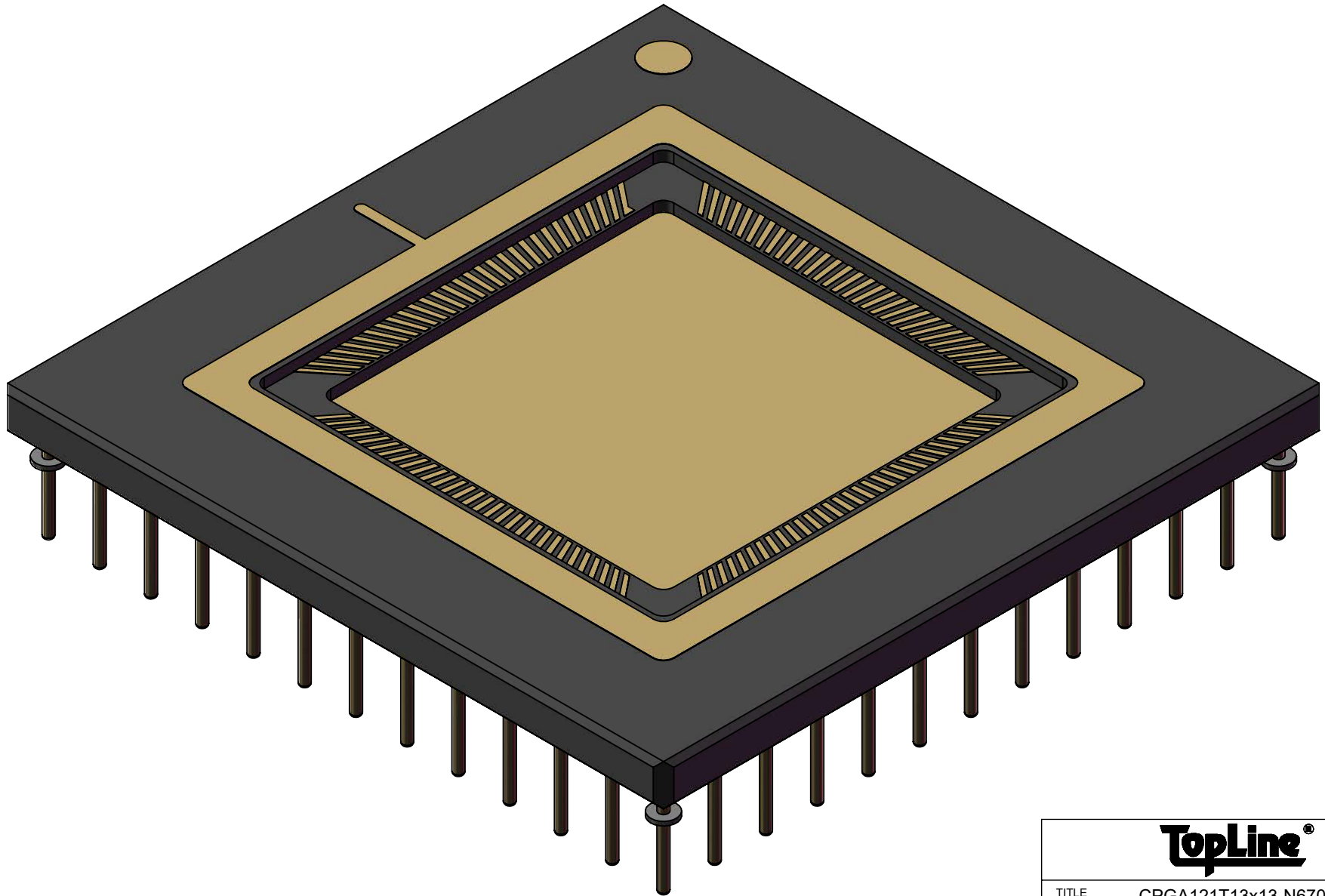

TopLine[®]

TITLE CPGA121T13x13-N670
CERAMIC PIN GRID ARRAY

| SCALE | SIZE | DRAWING NO. | REV |
|-------|------|-------------|-----|
| 5:1 | A | 168507 | A |

DO NOT SCALE DRAWING

SHEET 5 OF 7

**MODEL
BOTTOM**

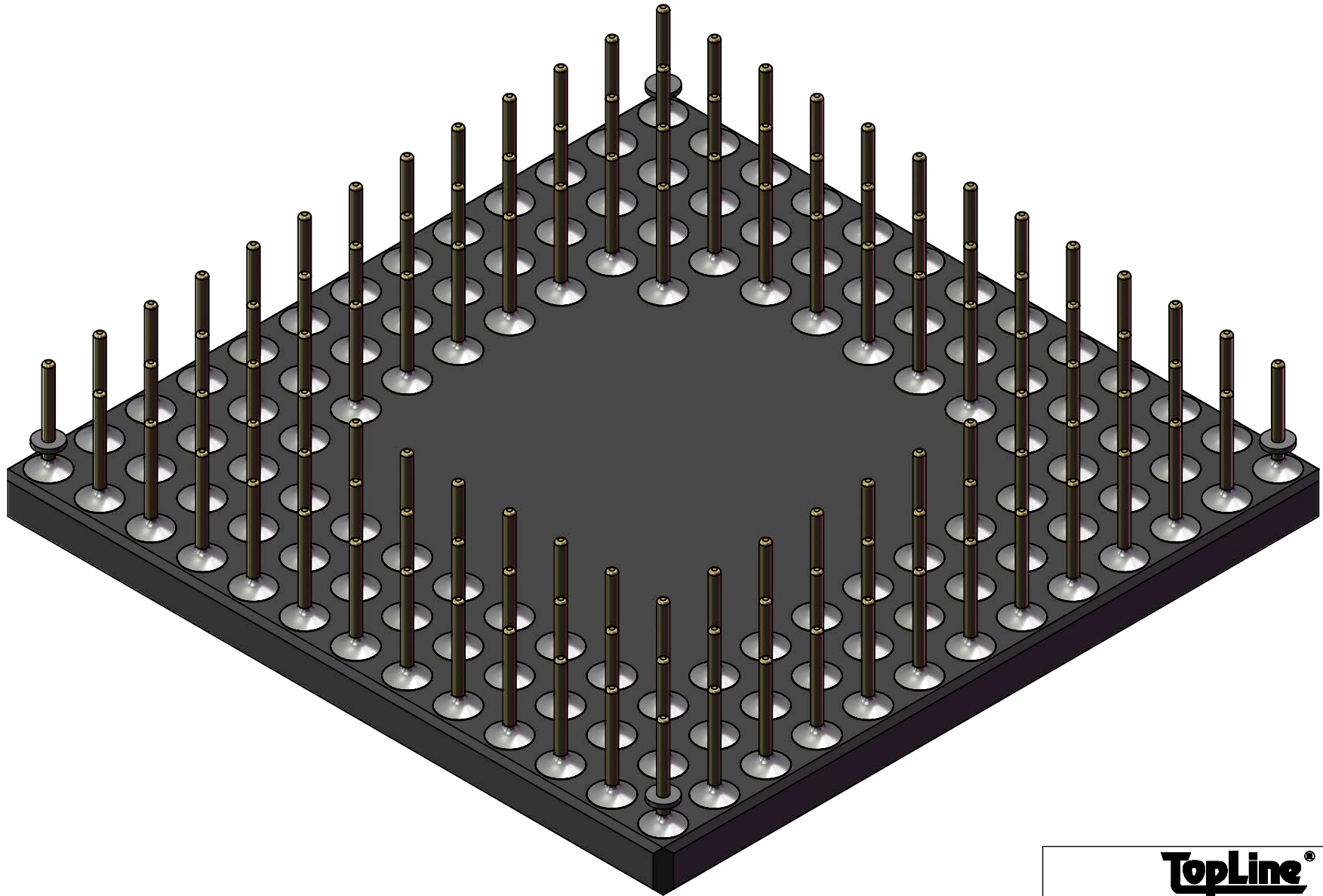

TopLine®

TITLE CPGA121T13x13-N670
CERAMIC PIN GRID ARRAY

| | | | |
|--------------|-----------|-----------------------|----------|
| SCALE 5:1 | SIZE A | DRAWING NO. 168507 | REV A |
|--------------|-----------|-----------------------|----------|

DO NOT SCALE DRAWING

SHEET 6 OF 7

OPTIONAL COMBO LID

BOTTOM

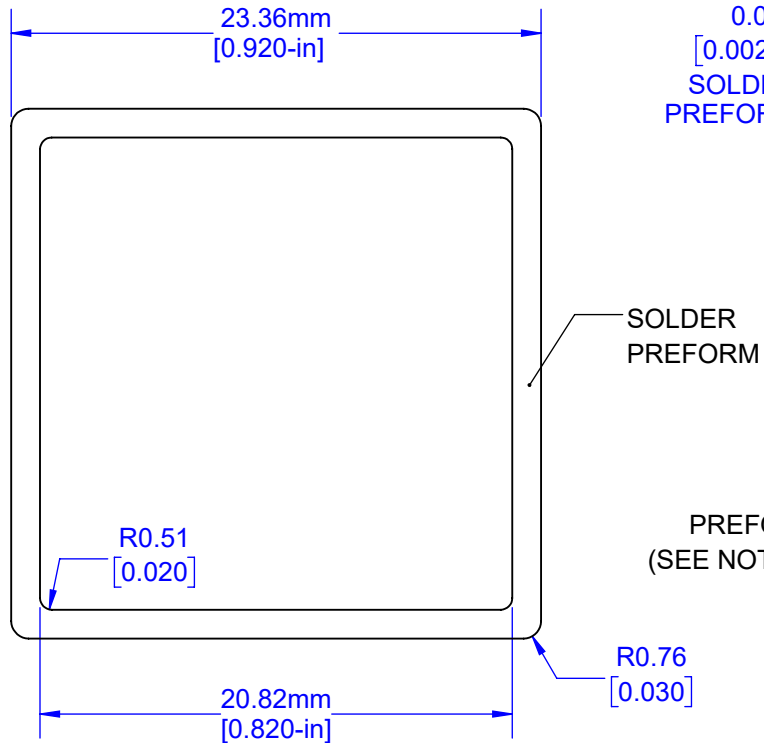

SIDE

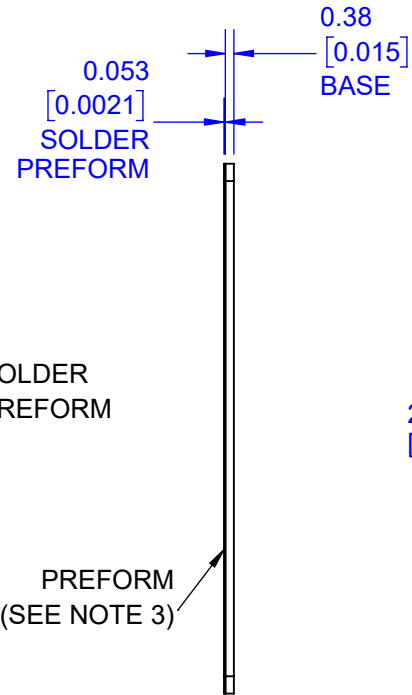

COMBO LID

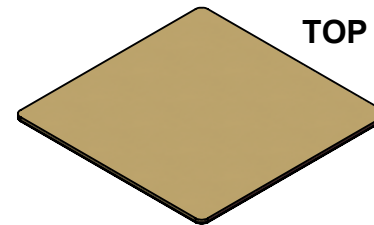
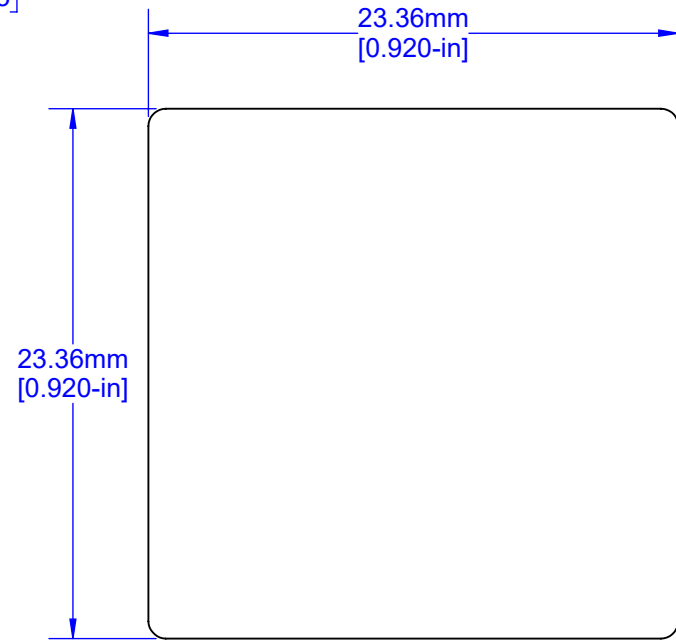

TOP

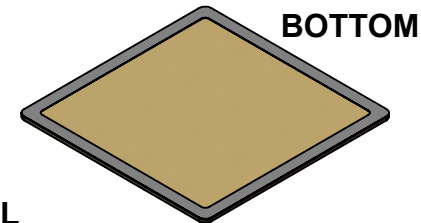

BOTTOM

MODEL

NOTES:

1. BASE MATERIAL: KOVAR or ALLOY 42.
2. PLATING: Ni 50~350 MICRO-INCH PER SIDE.
Au 25 MICRO-INCH MIN PER SIDE.
3. SOLDER PREFORM: Au 80% ±1.0 Sn 20%.
4. FLATNESS: 1.0 MIL (25µm) MAXIMUM PER 0.5-INCH (12.7mm).
5. DIMENSIONS MM [INCH].

REF HRC-2539

TopLine[®]

| | | | |
|----------------------|------|------------------------|--------------|
| TITLE | | CL920SQ-A COMBO LID | |
| SCALE | SIZE | DRAWING NO. | REV |
| 3:1 | A | 170920 | A |
| DO NOT SCALE DRAWING | | | SHEET 7 OF 7 |