

**TOP VIEW
(SIDE LOAD)**

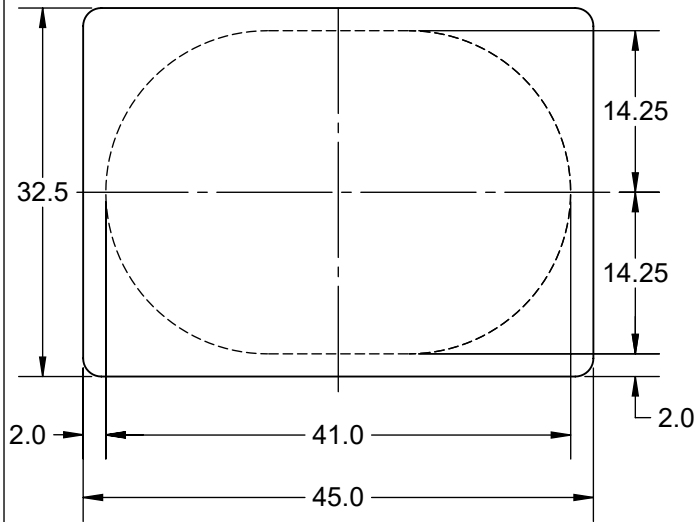

BOTTOM VIEW

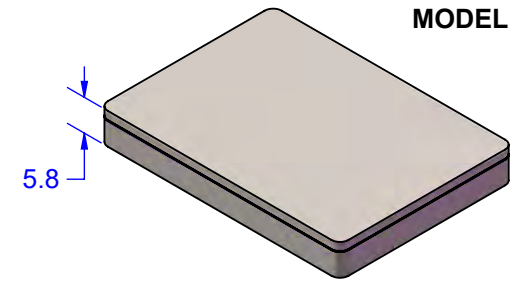
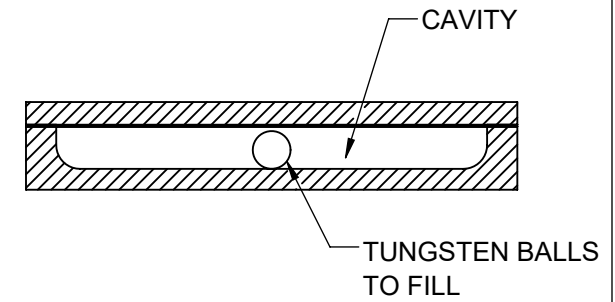
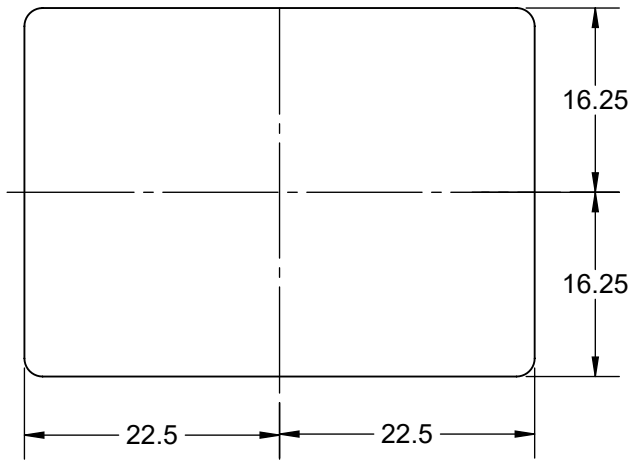

**U.S. PATENTS 10041558,
10021779, 10704639,
10704639, D842351**

DIMENSION AND WEIGHT (MASS) TABLE

H HEIGHT ±10%	PCB MASS NOM	TUNGSTEN BALLS IN CAVITY				Est. PID MASS	SCREW ADJUST	SCREW HEX HEAD
		∅ DIA	Per Ball	QTY	MASS			
5.8mm	21g	2.5mm	0.143g	~150	21g	40g	NA	NA

NOTES: (Unless Otherwise Specified).
1. DIMENSIONS: MM.
2. MOUNTING: GLUE TO PCB.

APPROVALS	DATE	TopLine®			
DRAWN T. Au	3/7/2024				
ENG M. Hart	3/7/2024	TITLE FA21R45x32.5x5.8A PID VIBRATION DAMPER			
MFG		SCALE	SIZE	DRAWING NO.	REV
QA		4:1	A	130213	A
CUST		DO NOT SCALE DRAWING			SHEET 1 OF 3
REVISED					

MODEL

TOP

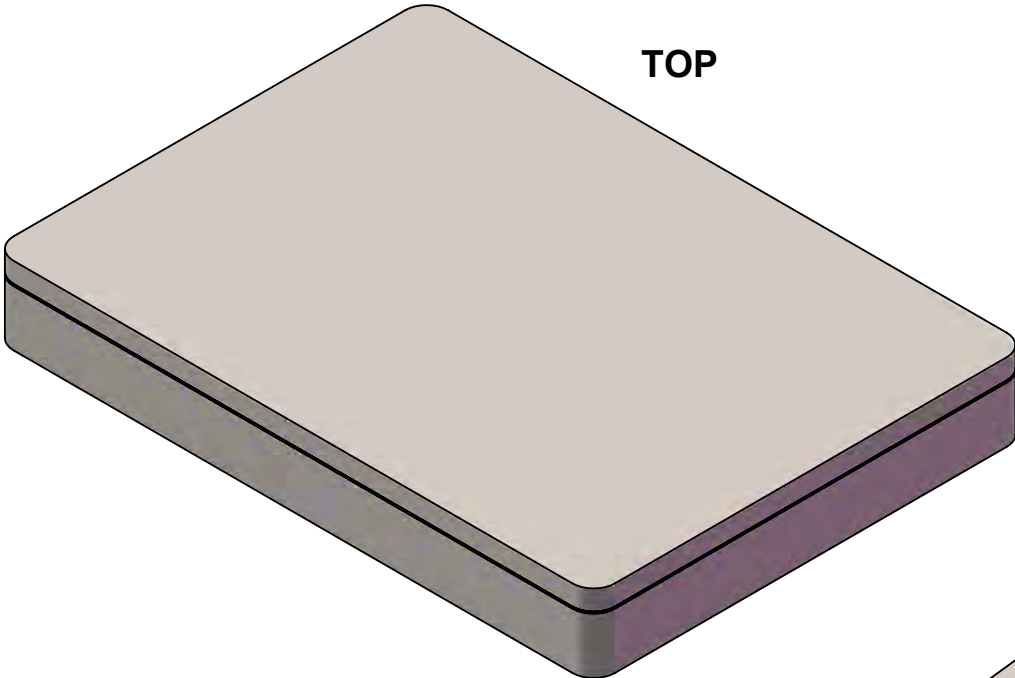

BOTTOM

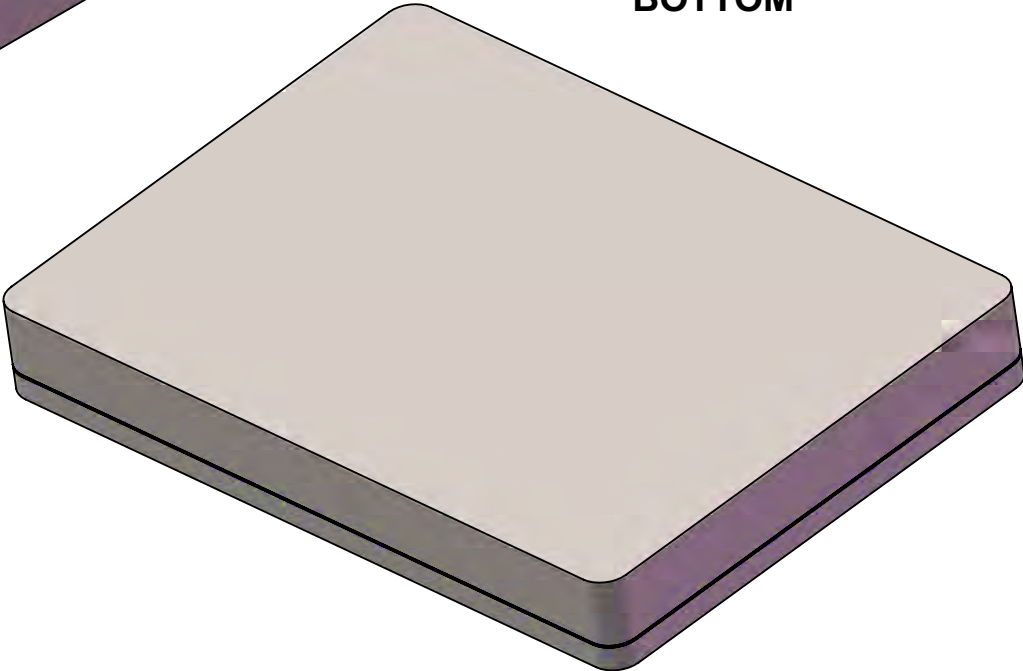

NOTES:
1. CONTACT TOPLINE FOR OTHER MOUNTING OPTIONS.

TopLine[®]			
TITLE FA21R45x32.5x5.8A PID VIBRATION DAMPER			
SCALE 4:1	SIZE A	DRAWING NO. 130213	REV A
DO NOT SCALE DRAWING		SHEET 2 OF 3	

Part Number System

<u>F</u>	<u>A</u>	<u>21</u>	<u>R</u>	<u>45x32.5</u>	<u>x5.8</u>	<u>A</u>
Series	Mounting on PCB	Tungsten Payload Grams	Exterior Shape	X/Y Size	Height	Version/Option
<u>Filled</u>	<u>Mounting Style</u>	<u>Code</u> <u>Grams</u>	<u>Code</u> <u>Shape</u>	<u>Code</u> <u>Size</u>	<u>Code</u> <u>Height</u>	<u>Code</u> <u>Version</u>
F = FR4	S = SCREW MOUNT A = ADHESIVE GLUE	21 = 21gm Other Mass Available	SQ Square R Rectangle C Cylindrical T Toroid Z Custom	45x32.5 = 45x32.5mm Other Sizes Available	5.8 = 5.8mm Other Sizes Available	A = 2.5mm TUNGSTEN B = 2.3mm TUNGSTEN Other Version Available
<u>Empty</u>						
E = FR4 Case						

Order Number

<u>1</u>	<u>3</u>	<u>021</u>	<u>3</u>
DESCRIPTION	Mount Style	Mass (gm) 9 = Decimal	Option Code
<u>Code</u> <u>Description</u>	<u>Code</u> <u>Description</u>	<u>Code</u> <u>MASS</u>	<u>Code</u> <u>Option</u>
1 = Filled PID	2 = Screw 3 = Adhesive 9 = Custom 0 = Master DWG	021 = 21 gm	3 = A = 2.5mm TUNGSTEN 4 = B = 2.3mm TUNGSTEN

TopLine®

TITLE FA21R45x32.5x5.8A
PID VIBRATION DAMPER

SCALE NONE	SIZE A	DRAWING NO. 130213	REV A
---------------	-----------	-----------------------	----------

DO NOT SCALE DRAWING

SHEET 3 OF 3