

STYLE FS
SCREW HOLE
OPTIONAL

TOP

SIDE

BOTTOM
(NOTE 2)

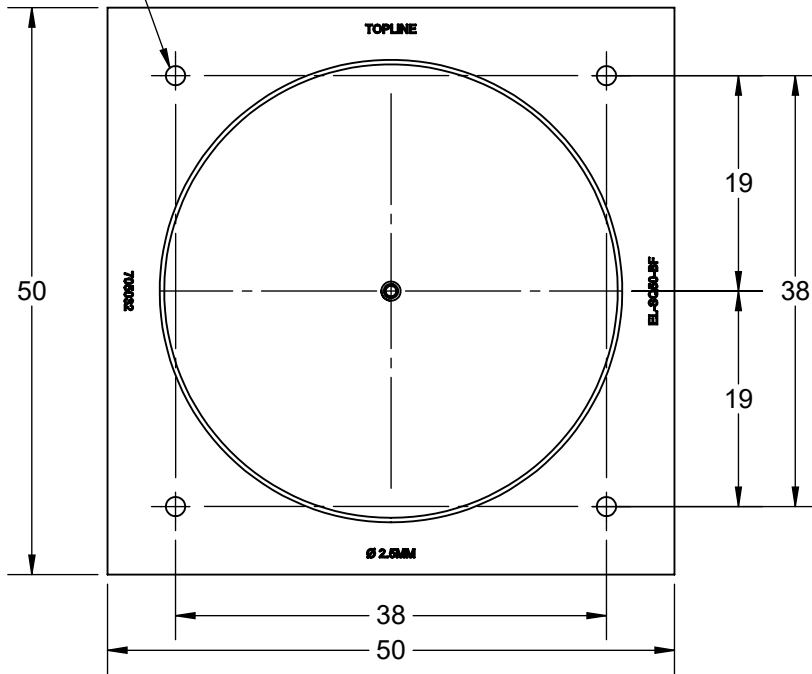

ADJUST

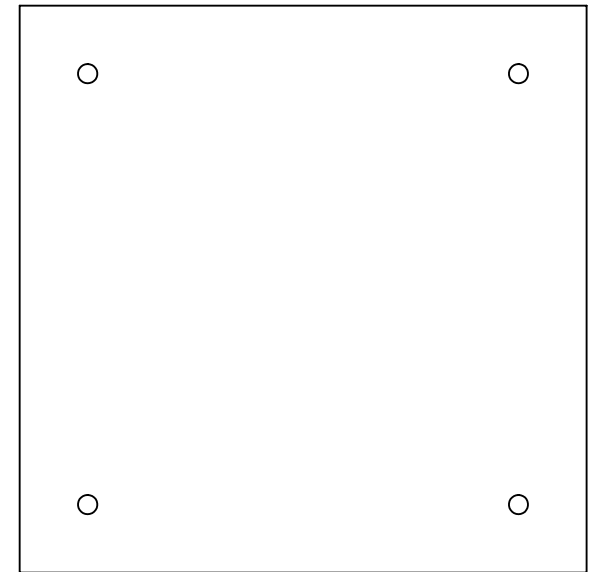
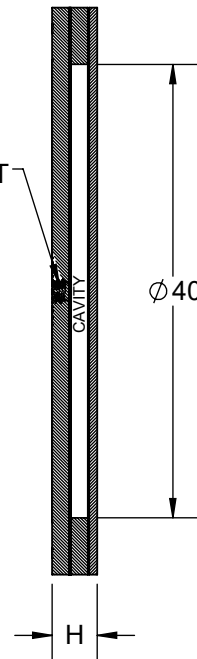

SCREW OPTIONAL

DIMENSION AND WEIGHT (MASS) TABLE

| H HEIGHT ±0.5 mm | PCB MASS | TUNGSTEN BALLS IN CAVITY | | | | Total PID MASS | SCREW ADJUST | SCREW HEX HEAD |
|------------------------|-------------|--------------------------|----------|------|------|----------------------|-----------------|----------------------|
| | | Ø DIA | Per Ball | QTY | Mass | | | |
| 5.0mm | 230g | 2.3mm | 0.102g | ~225 | 23g | 42g | 6-32 | 1/16 |
| 7.5mm | 270g | 2.5mm | 0.143g | ~190 | 27g | 56g | 6-32 | 1/16 |
| 8.0mm | 320g | 3.0mm | 0.248g | ~132 | 32g | 64g | 8-32 | 5/64 |
| 9.0mm | 420g | 4.0mm | 0.587g | ~72 | 42g | 80g | 10-32 | 3/32 |
| 13mm | 510g | 5.0mm | 1.146g | ~45 | 51g | 106g | 1/4-28 | 1/8 |

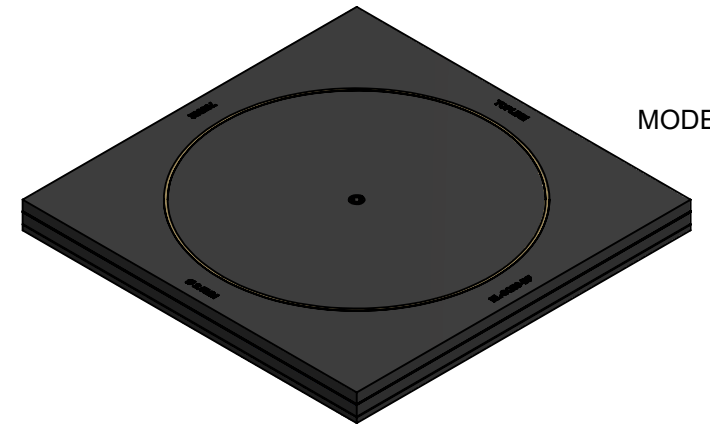

NOTES: (Unless Otherwise Specified).

1) DIMENSIONS mm

APPLICATION NOTES:

Contact TopLine for help to select the best PID for your application.

NOTES 2 MOUNTING STYLE

2= SCREW (FS)

3= ADHESIVE (FA)

PATENTS THAT MAY APPLY ON PAGE 4

| | | | | | |
|-------------|----------|--|------|-------------|--------------|
| APPROVALS | DATE | TopLine® | | | |
| DRAWN T. Au | 7/5/2021 | | | | |
| ENG M. Hart | 7/5/2021 | TITLE EL-SQ50-BF PID VIBRATION DAMPER | | | |
| MFG | | SCALE | SIZE | DRAWING NO. | REV |
| QA | | 2.5:1 | A | 705032 | A |
| CUST | | DO NOT SCALE DRAWING | | | SHEET 1 OF 4 |
| REVISED | | | | | |

MODELS

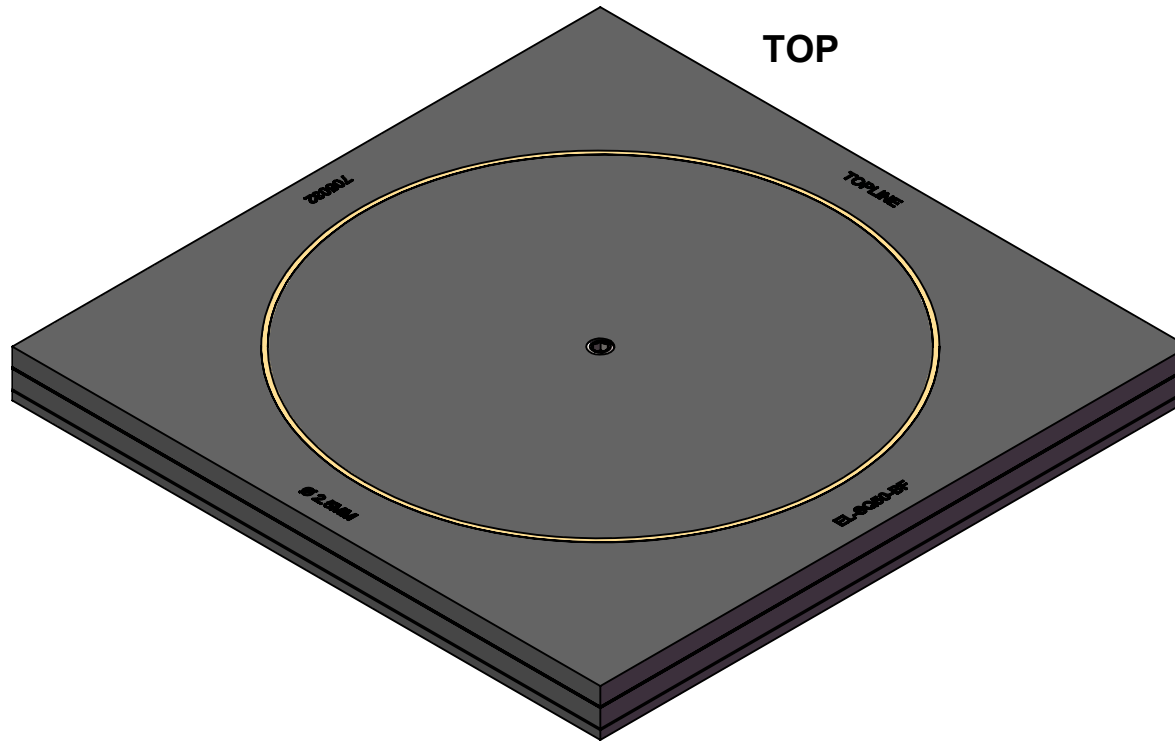

TOP

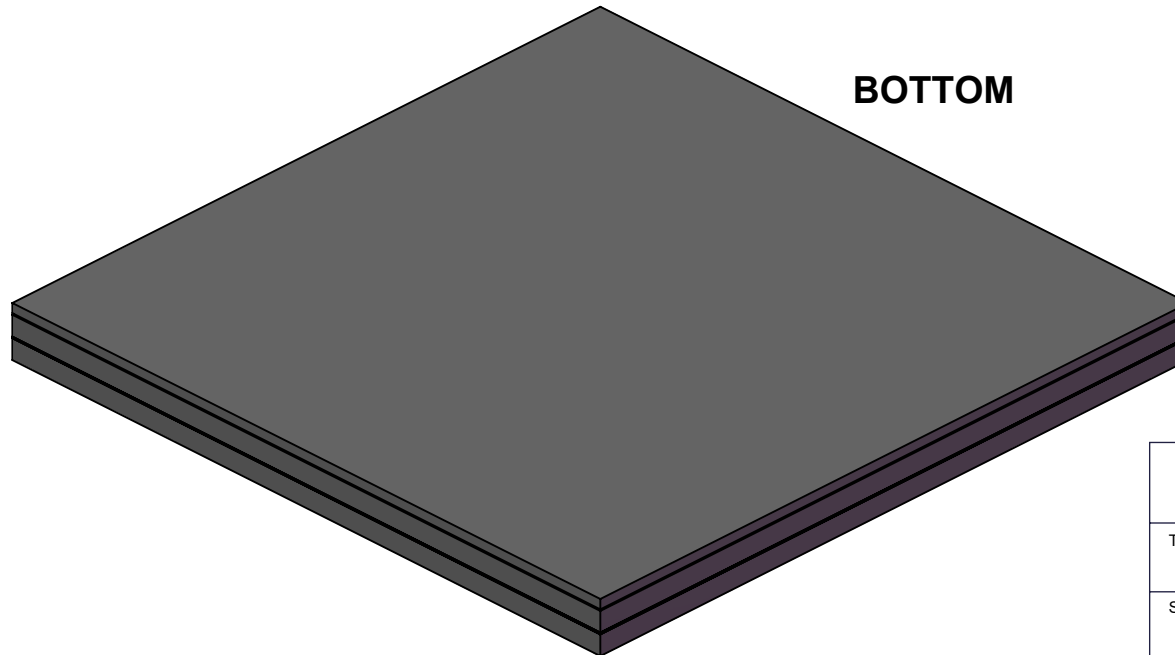

BOTTOM

**STYLE FA
ADHESIVE
(GLUE)**

TopLine®

TITLE EL-SQ50-BF
PID VIBRATION DAMPER

| | | | |
|----------------|-----------|-----------------------|----------|
| SCALE 2.5:1 | SIZE A | DRAWING NO. 705032 | REV A |
|----------------|-----------|-----------------------|----------|

DO NOT SCALE DRAWING

SHEET 2 OF 4

PART NUMBER SYSTEM

| <u>F</u> | <u>A</u> | <u>27</u> | <u>SQ</u> | <u>50X</u> | <u>7.5</u> | <u>A</u> |
|--|--|--|--|--|--|--|
| Series | Mounting on PCB | Tungsten Payload Grams (Mins.) | Shape | X/Y Size | Height | Version/Option |
| <p>Filled F = FR4 Case A = Al Case</p> <p>Empty E = FR4 Case L = Al Case</p> | <p>Mounting Style A = Adhesive S = Screw Fastener</p> | <p>Code • Grams 23 = 23gm 27 = 27gm 32 = 32gm 42 = 42gm 51 = 51gm</p> <p>Other Mass Available</p> | <p>Code • Shape SQ = Square R = Rectangle C = Cylindrical T = Toroid Z = Custom</p> | <p>Code Size 50X = 50mm SQ</p> <p>Other Sizes Available</p> | <p>Code Height 5.0 = 5.0mm 7.5 = 7.5mm 8.0 = 8.0mm 9.0 = 9.0mm 13 = 13mm</p> <p>Other Sizes Available</p> | <p>Code Version A Standard</p> <p>Other Version Available</p> |

ORDER NUMBER

| <u>1</u> | <u>3</u> | <u>027</u> | <u>2</u> |
|--|---|---|--|
| DESCRIPTION | Mount syle | Mass (gram) | Option Code |
| <p><u>Code • Description</u> 1 = Filled PID 5 = Eng Dev Kit 7 = Empty Pkg</p> | <p><u>Code • Description</u> 2 = Screw (S) 3 = Glue (A) 9 = Custom 0 = Master DWG</p> | <p><u>Code • Grams</u> 023 = 23gm 027 = 27gm 032 = 32gm 042 = 42gm 051 = 51gm</p> | <p>1 Version A 2 Version B 3 Version C ... 9 Version J</p> |

| | | | |
|--|-----------|-----------------------|----------|
| TopLine® | | | |
| TITLE EL-SQ50-BF PID VIBRATION DAMPER | | | |
| SCALE NONE | SIZE A | DRAWING NO. 705032 | REV A |
| DO NOT SCALE DRAWING | | SHEET 3 OF 4 | |

U.S. PATENTS PARTICLE IMPACT DAMPERS

| | U.S. PATENT NBR | GRANTED | TITLE |
|---|--------------------|---------|---|
| 1 | 9,521,753 | 2016 | Vibration damping circuit board assembly |
| 2 | 10,041,558 | 2018 | Tunable apparatus for adjusting effective performance of particle impact damper |
| 3 | 10,021,779 | 2018 | Quick response particle damper for printed circuit boards and planar surfaces |
| 4 | D842351 | 2019 | Toroidal shaped particle impact damper |
| 5 | 10,704,639 | 2020 | Unidirectional particle damper for printed circuit boards and planar surfaces |

U.S. PATENTS REGISTERED TRADEMARKS

| REGISTRATION | GRANTED | MARK | GOODS & SERVICES |
|--------------|---------|----------------------|---|
| 5,469,015 | 2018 | Inspired by Gravity® | Class 9. Electronic components namely particle impact dampers for attenuating vibration in printed circuit boards and mechanical assemblies |

TopLine®

TITLE
EL-SQ50-BF
PID VIBRATION DAMPER

| | | | |
|---------------|-----------|-----------------------|----------|
| SCALE NONE | SIZE A | DRAWING NO. 705032 | REV A |
|---------------|-----------|-----------------------|----------|

DO NOT SCALE DRAWING

SHEET 4 OF 4