

### HCD'J-9K

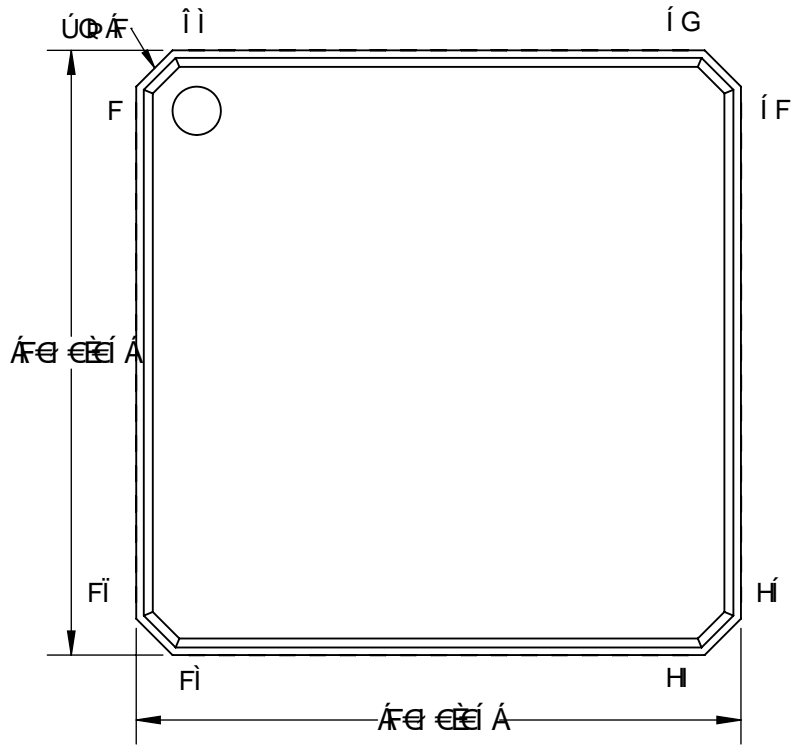

### G-89'J-9K

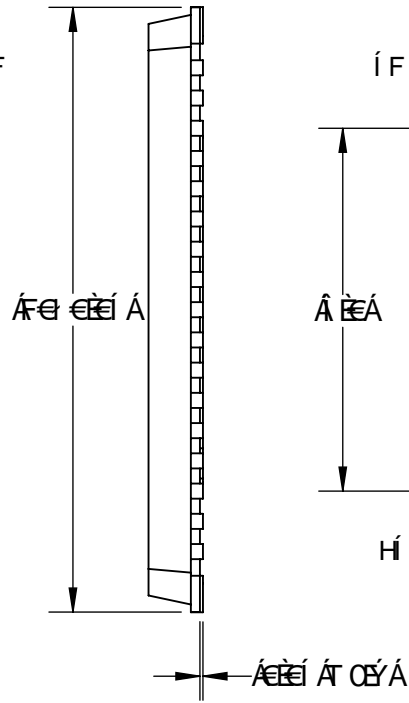

### 6CHCA'J-9K

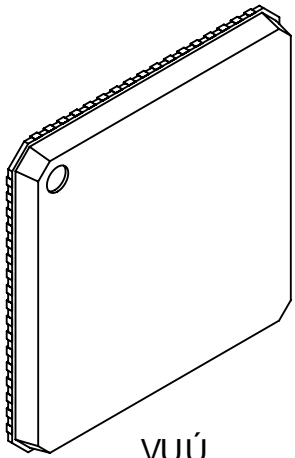
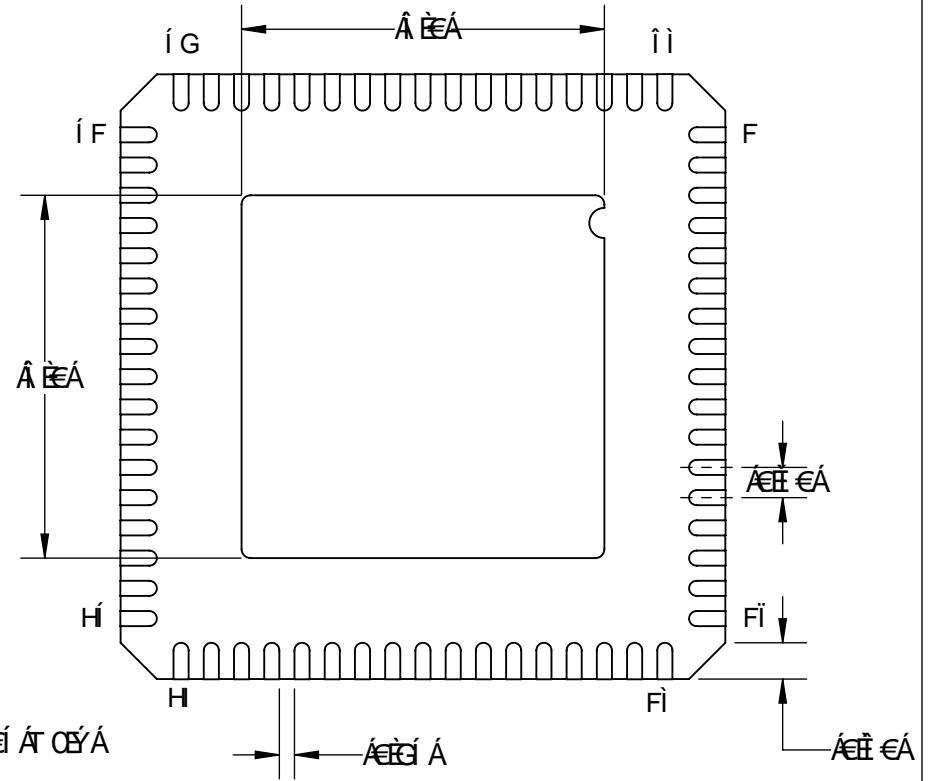

VUÚ

TUÖÖŠ

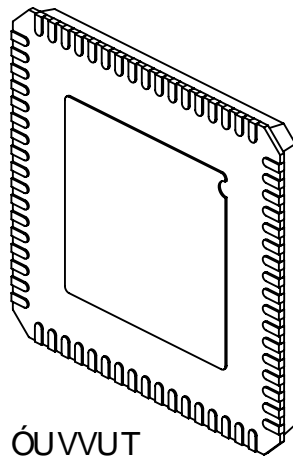

ÓUVVUT

Π[ c • K V | • • Á @ ! , ã ^ Á ] ^ & a a ã ð  
 F D O U Ö Y K A U S C E U V O E A U O T O U P O W O N U U A O U O C O E  
 G S O C O A U C E T O K O U U U O U E O E J I A O P E  
 H S O C O A U C E T O A U S O V O O K A U A C E E  
 I D O U C E T O A P O S P O U U K E I G H { E  
 Í D O O A U C E K A E A E E { A T O E A O Y U U O O A U C O E  
 Î D R O O O O A U W S O O K T U E G G E  
 Ï D O Q O P U O P U A O A { E

ΟΕΥΟΥΧΟΕΣΥ	ΟΕΥ/Ο	<b>TopLine®</b>			
ΟΥΟΕΥ P A A A V E E E	Í Θ B E G E				
ΟΠΟ T B P a s c	Í Θ B E G E	VAÖŠO	Í Î Š O C O A F e { Á U E E { { T S O A U O P D O C E U Y A O P O E P		
T Ø					
ÚCE		ÚOCŠO	ÚAZO	ÓUY O O A U E	ÚOX
ÓWUV		í K	CE	ííííí F	CE
ÚOXΩÍOÓ		ÓU A U V A Ú O C Š O Ó U C E O O			ÚP O O V / A U Z A



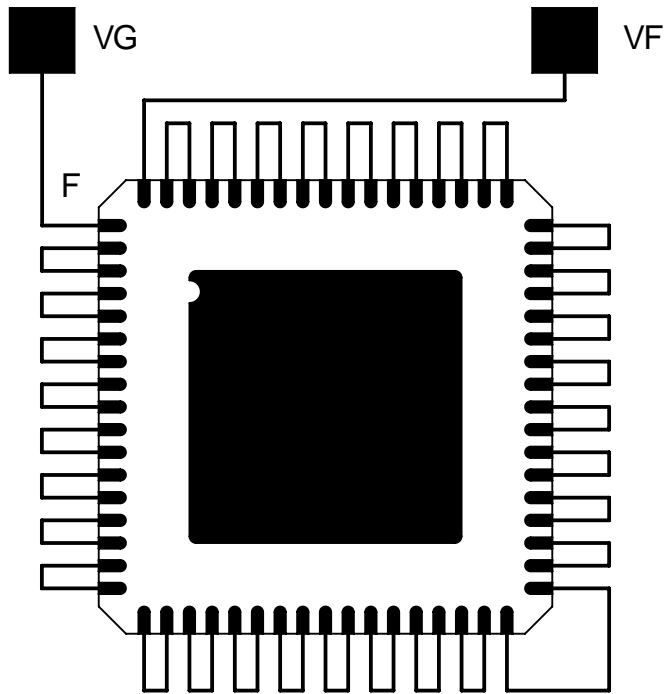

ÜÒÔÛΤΤ ÒÞ ÖÖÁ  
 ÜÓÁÚÇÛ

îì

íG

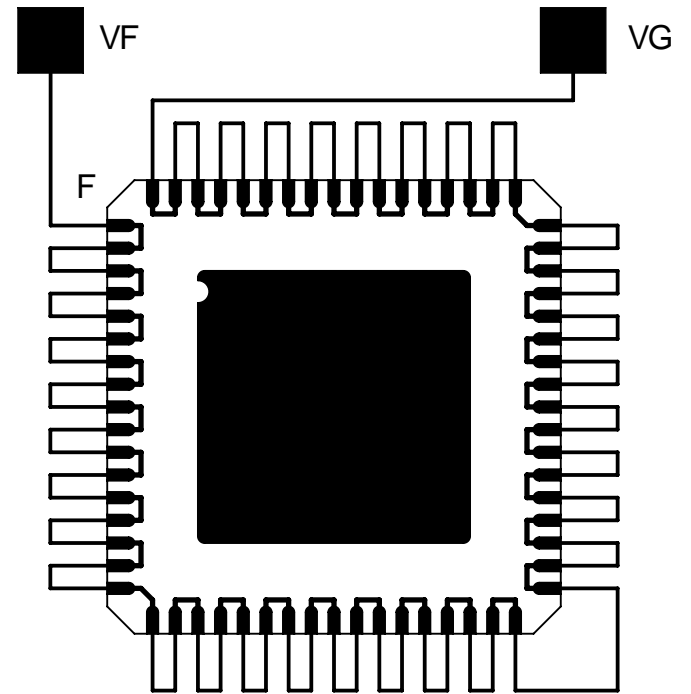

ÇØVÒÛÁΤ ÛWÞ VÇ Ò  
 ÛPÁÚÇÛ

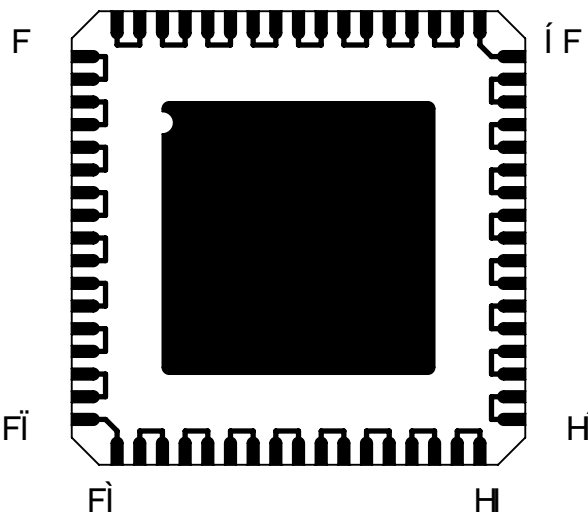

XÇÛY ÅÛÛT ÁUÚ

85-GM7<5-B  
 B9H@GH

ÚÇÛ	ÚÇÛ	ÚÇÛ
FÁÁG	HÁÁ	íÁÁ
ïÁÁ	JÁÁ€	ÁFÁÁG
FHÁÁI	FíÁÁí	ÁíÁÁí
FJÁÁGE	GFÁÁGG	ÁÇÁÁG
íÁÁí	GíÁÁí	GJÁÁ€
HFÁÁG	HHÁÁH	HíÁÁí
HíÁÁí	HJÁÁ€	IFÁÁG
IHÁÁI	ííÁÁî	ííÁÁì
IJÁÁ€	íFÁÁG	íHÁÁI
ííÁÁî	ííÁÁì	íJÁÁ€
îFÁÁG	îHÁÁI	îíÁÁî
îíÁÁì		

**TopLine®**

varso ììÈÖÇÁ€ { ÁÚÈ { {  
 T SÇÇÛ ÇP DÇÇÛYÁÇP ÇP

ÚÇÇÖ íK	ÚÇÖ ÇE	ÖÚÇ ÇÖÇUÈ ííííF	ÚÇX ÇE
ÖUÇUÚVÁÚÇÇÖÖÚÇÇ ÇÖ			ÛPÇÇVÁÚÇÇÁ

D7 '6 C5 F8 ' @ MCI H  
 8 -A9BG-CBG-B'AA  
 J-9K : FCA'HCD

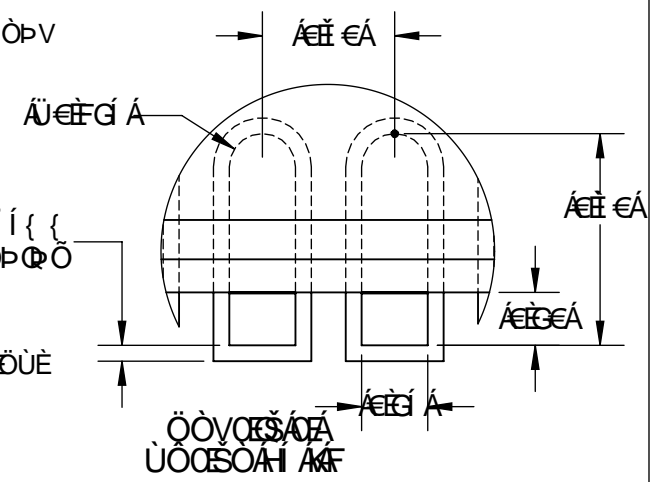
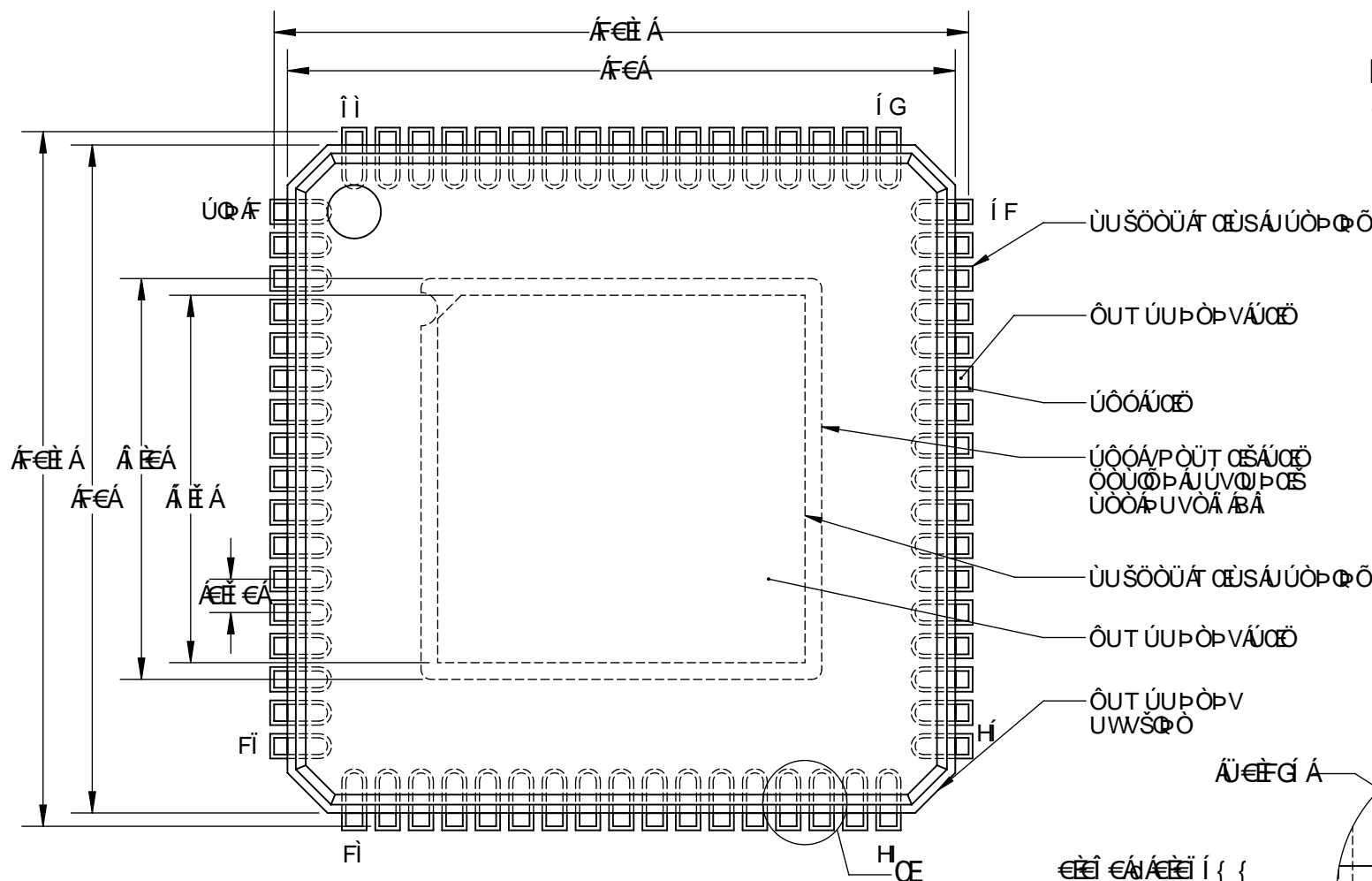

ΠΙ...  
 F...  
 W...  
 G...  
 H...  
 I...  
 J...  
 K...  
 L...  
 M...  
 N...  
 O...  
 P...  
 Q...  
 R...  
 S...  
 T...  
 U...  
 V...  
 W...  
 X...  
 Y...  
 Z...

<b>TopLine®</b>			
varso $\hat{i}\hat{l}\hat{E}\hat{S}\hat{O}\hat{O}\hat{A}\hat{F}\hat{e}\hat{i}\{\hat{A}\hat{E}\hat{I}\hat{A}\{\{\}$ T S O A J U P D O C E W Y A O P C E			
uocso $\hat{i}\hat{K}$	uao CE	ouay p o a ue $\hat{i}\hat{i}\hat{i}\hat{i}\hat{F}$	uox CE
ou a u u u o a s o d u c e p o		u p o o v a j u z a	

D5 FH'BI A 6 9 F -B; 'GMGH9 A

A @ \* ,  
 ÚVŸŠÒ  
 UWWŠÒ

ÚWÖÄŠÖV  
 ÞUŠÖÖ  
 ÌÌŠÖÖÙ

H  
 ÚÖÔŠÖÖÖ

VÁVÜĚ  
 ÖÄWÁÖÛ  
 ÖIÖÄÄÜÖÖŠ

")  
 ÚQÔP

Ě ÁĚ T T

! H  
 ÚŠÖVÖ

VÁVÜ} F€€  
 T æ^Áā

! 8 9  
 ÔŮŮW

ÖÖÄWÖYÄPÖ  
 ŮUÁWUŠÖVÖÖ  
 ÖŠÖSÁWÖWT T Ÿ

! 8  
 UÚVÖÞ

ÖŠÖSÁWUÄÖ  
 ÖÄWÖWT T ŸÖÖ

\* '\$  
 ÚÖÖ

T ÖYÖWT  
 ÖYUUÖÖ  
 ÖÖÄÖ

D5 FH'BI A 6 9 F	8 5 -GM 7 < 5 -B	D5 7 ? 5 ; -B;	Fc < G DVI: F99	D'U]b[	8 I A A M 8 -9
T Šđ ì VĚ ĚÖÖÖ	ŸÖÙ	RÖÖÖÖÄÜĚ	ŸÖÙ	Ú} F€€	ŸÖÙ
T Šđ ì VĚ ĚÖÙ	ŮUŠÖVÖÖ	RÖÖÖÖÄÜĚ	ŸÖÙ	Ú} F€€	ÞU
T Šđ ì VĚ ĚÖ	ÞU	RÖÖÖÖÄÜĚ	ŸÖÙ	Ú} F€€	UÚVÖÞÖŠ

UVPOÜÄÜVÄWT ÖÖÜÖÖT ÖÖÖVÖÞÜÖÖÖÖÖÖÖVÖÖVÄUÜŠÖÖ

**TopLine®**

vāšö ÌÌŠÖÖÄF€ { ÄĚ { {  
 T Šđ Ů} ÞÖÖÖYÄPÖ

ÚÖÖÖ ÞUÞÖ	ÚÖÖ Ö	ÖÜÖ ÖÖÖÜ ÌÌÌÌF	ÜÖ Ö
--------------	----------	-------------------	---------

ÖÜÖUVÜÖÖÖÖÜÖÖÖÖ ÜPÖÖVÄÄÖ