

**TOP VIEW  
SHOWN WITH LID**

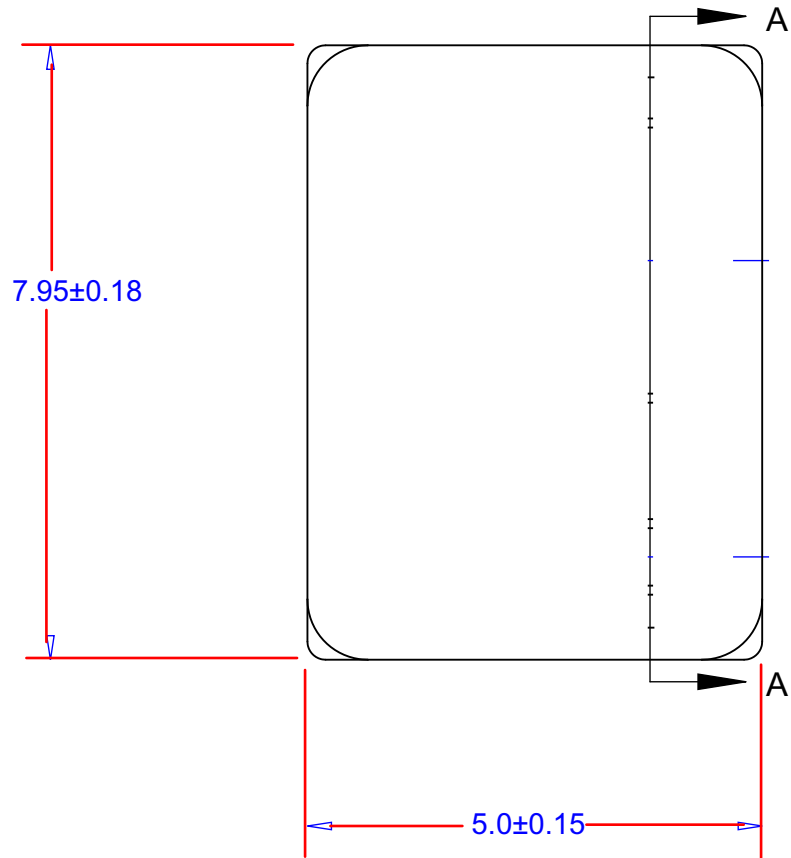

**SIDE VIEW**

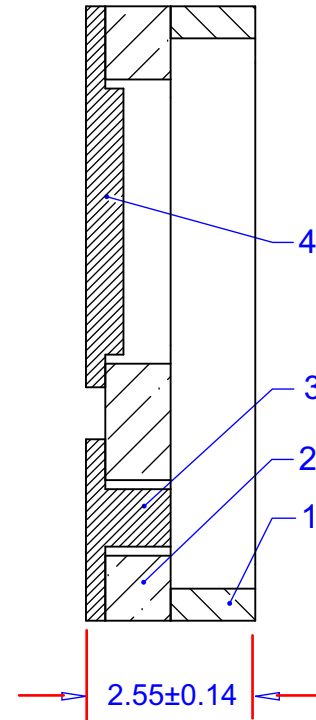

**BOTTOM VIEW**

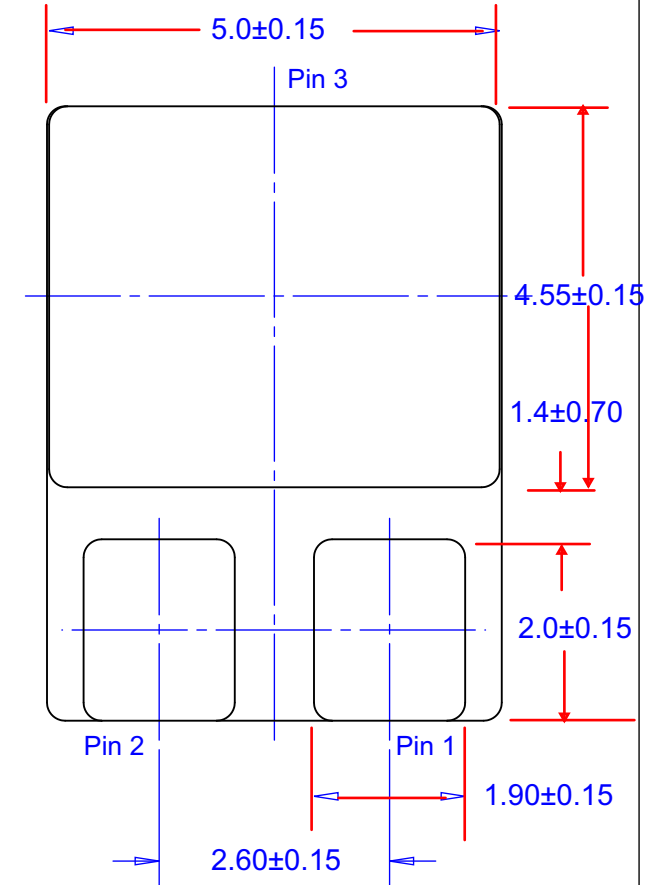

Part Number Table					
Part Number		Daisy Chain	Dummy Die	Attached Lid	DWG Number
SMD.2W-N		NO	NO	NO	800020
SMD.2W-ISO		NO	NO	YES	800021
SMD.2W-DC123		YES	NO	YES	800022
SMD.2W-DC123D		YES	YES	YES	800023
SMD.2W		NO	NO	YES	800029
LID SMD.2W		-	-	Unattached	200002

APPROVALS	DATE				
DRAWN T.Au	09/16/16				
ENG M. Hart	09/16/16	TITLE SMD.2W POWER PACKAGE			
MFG		SCALE 8:1	SIZE A	DRAWING NO. 800020	REV A
QA					
CUST					
REVISED		DO NOT SCALE DRAWING			SHEET 1 OF 4

**INTERNAL WIRING CIRCUIT (JUMPER)  
DAISY CHAIN PART NUMBER SUFFIX  
TOP VIEW**

OPTIONAL DUMMY DIE

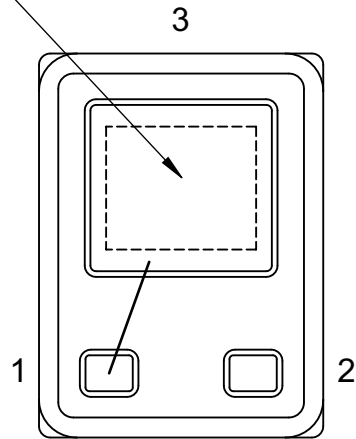

**DC13  
WITH LID  
ATTACHED**

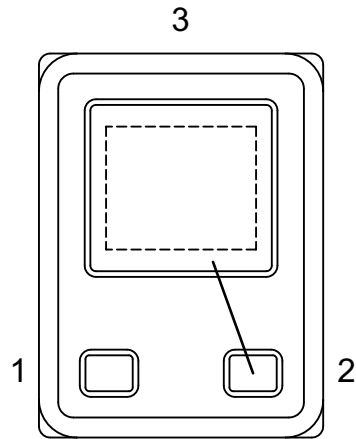

**DC23  
WITH LID  
ATTACHED**

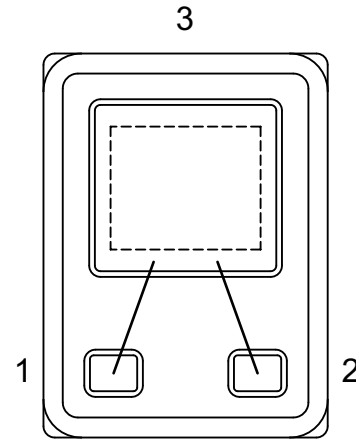

**DC123  
WITH LID  
ATTACHED**

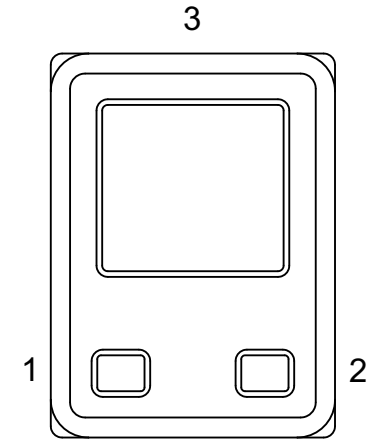

**OPTION -N  
OPEN CAVITY  
WITHOUT LID ATTACHED**

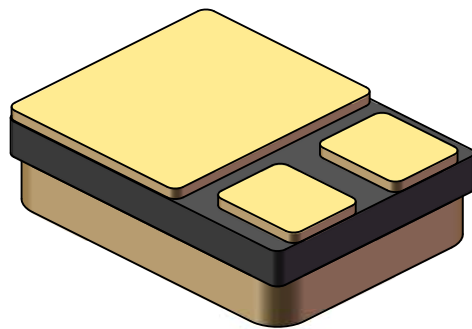

**BOTTOM  
VIEW OF TERMINALS**

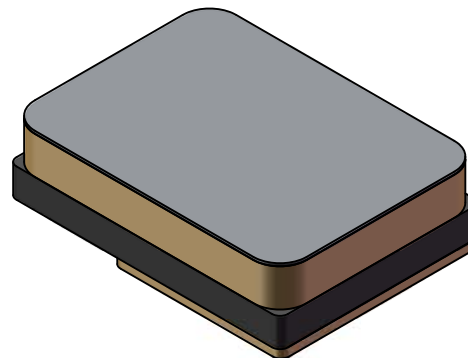

**TOP  
LID ATTACHED**

<b>TopLine®</b>			
TITLE		SMD.2W POWER PACKAGE	
SCALE	SIZE	DRAWING NO.	REV
5:1	A	800020	A
DO NOT SCALE DRAWING			SHEET 2 OF 4

## SCHEMATIC EQUIVALENT INTERNAL CIRCUIT

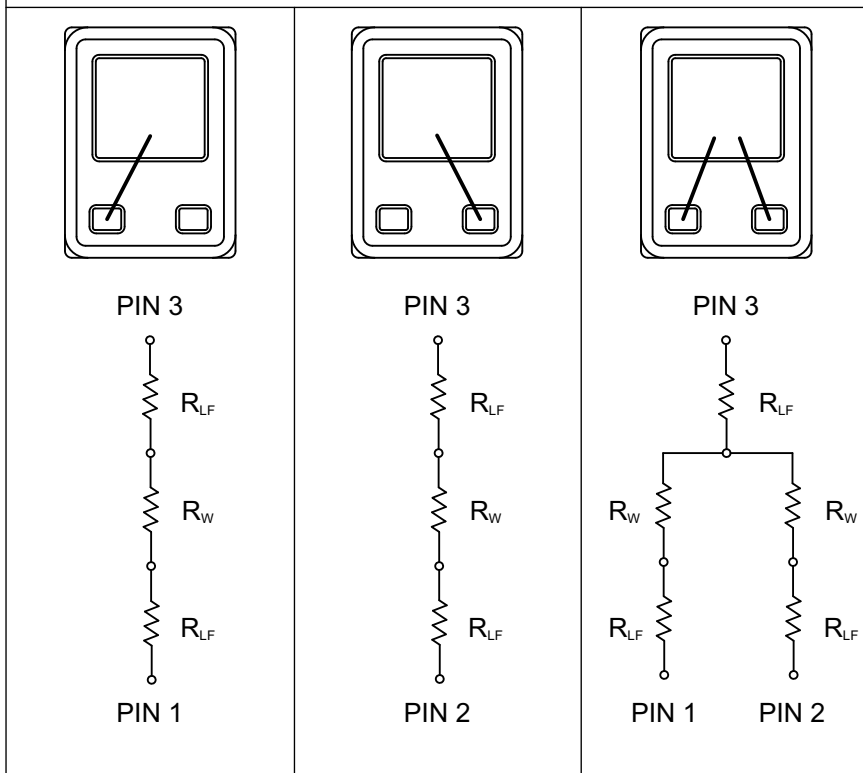

$R_W$  = GOLD WIRE-BOND.  
 $R_{LF}$  = LEAD FRAME.

### NOTES:

GENERAL SPECIFICATIONS COMPLY WITH MIL-STD-750E AND SCREENED PER MIL-PRF-38354.

1. MATERIAL: SEE BOM.
2. FINAL FINISH: 50-MICRO-INCH GOLD OVER 100-MICRO-INCH (MIN) NICKEL.
3. PARTS EQUAL OR EXCEED  $10^{10}$  OHMS ISOLATION TEST WITH 500VDC PINS TO CASE.
4. BREAKDOWN VOLTAGE: 1000V BREAKDOWN VOLTAGE TEST WITH NORMAL TESTING CONDITIONS (PADS AND CASE).

ELECTRICAL RESISTANCE MILLIOHM (DC) MAX			
CIRCUIT	PIN 1 TO 3	PIN 2 TO 3	PIN 1 TO 2
DC13	< 100 m $\Omega$	--	--
DC23	--	< 100 m $\Omega$	--
DC123	< 100 m $\Omega$	< 100 m $\Omega$	< 200 m $\Omega$

BILL OF MATERIAL		
ITEM	COMPONENT NAME	RAW MATERIAL
1	FRAME	KOVAR/4J29
2	CERAMIC	AL203 90% BLACK
3	BIG PAD	W85CU15
4	TWO SMALL PADS	KOVAR

**TopLine**<sup>®</sup>

TITLE			
SMD.2W POWER PACKAGE			
SCALE	SIZE	DRAWING NO.	REV
2.5:1	A	800020	A
DO NOT SCALE DRAWING			SHEET 3 OF 4

# PART NUMBERING SYSTEM

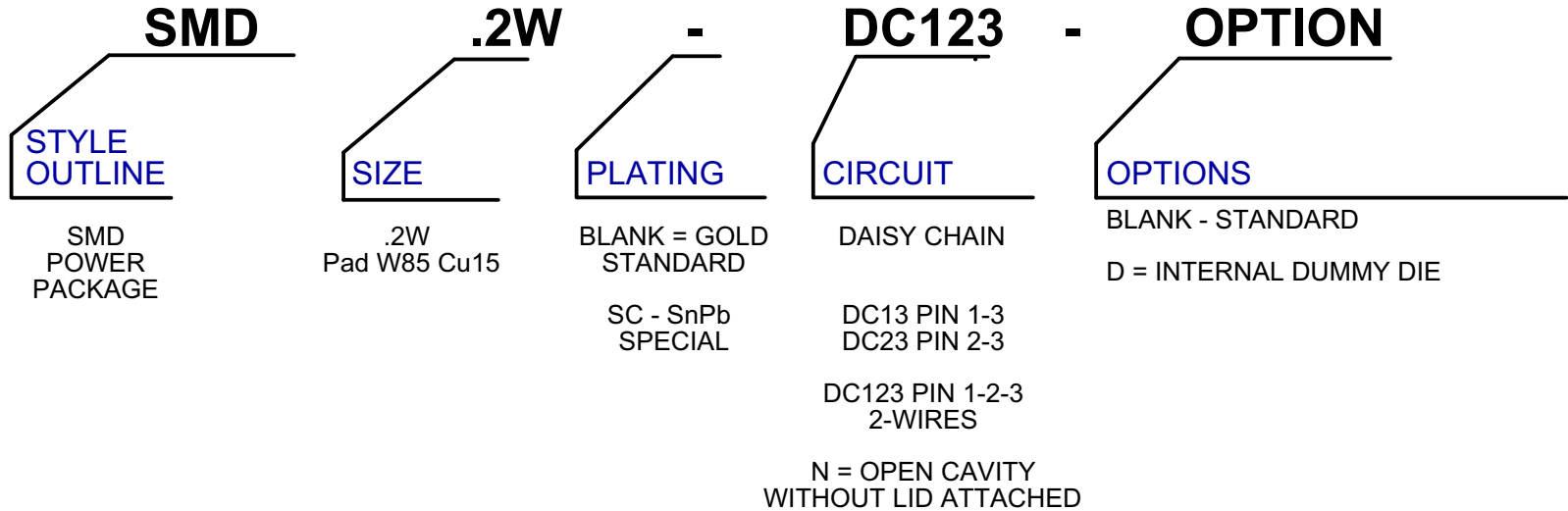

PART NUMBER	CONNECTED PINS	NOTES	SEALED LID	DUMMY DIE
SMD.2W	N/A	DUMMY	YES	N/A
SMD.2W-D	N/A	DUMMY	YES	YES
SMD.2W-N	NONE	ISOLATED	NO	NO
SMD.2W-DC13	1 ~ 3	DAISY CHAIN	YES	NO
SMD.2W-DC13D	1 ~ 3	DAISY CHAIN	YES	YES
SMD.2W-DC23	2 ~ 3	DAISY CHAIN	YES	NO
SMD.2W-DC23D	2 ~ 3	DAISY CHAIN	YES	YES
SMD.2W-DC123	1 ~ 2 ~ 3	DAISY CHAIN	YES	NO
SMD.2W-DC123D	1 ~ 2 ~ 3	DAISY CHAIN	YES	YES

<b>TopLine®</b>			
TITLE SMD.2W POWER PACKAGE			
SCALE 1:1	SIZE A	DRAWING NO. 800020	REV A
DO NOT SCALE DRAWING			SHEET 4 OF 4