

TOP VIEW

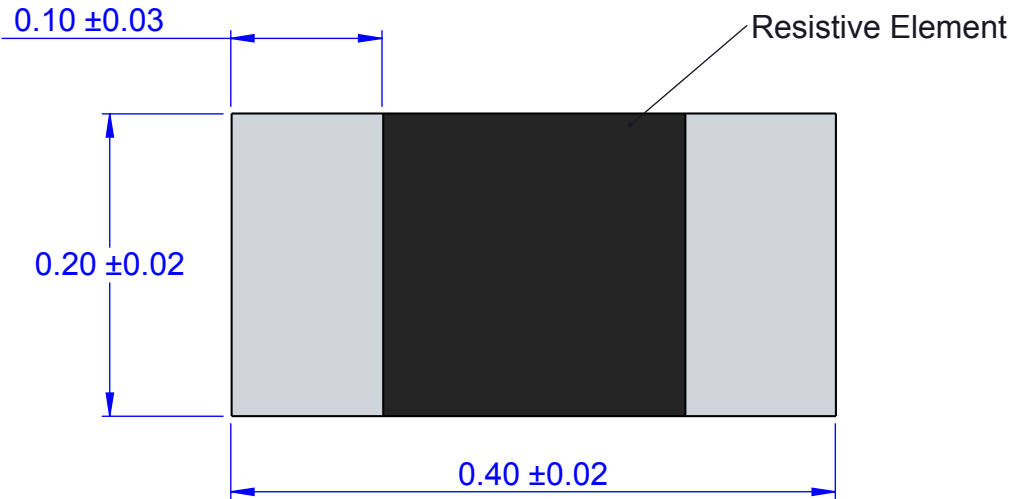

RECOMMENDED PCB PATTERN

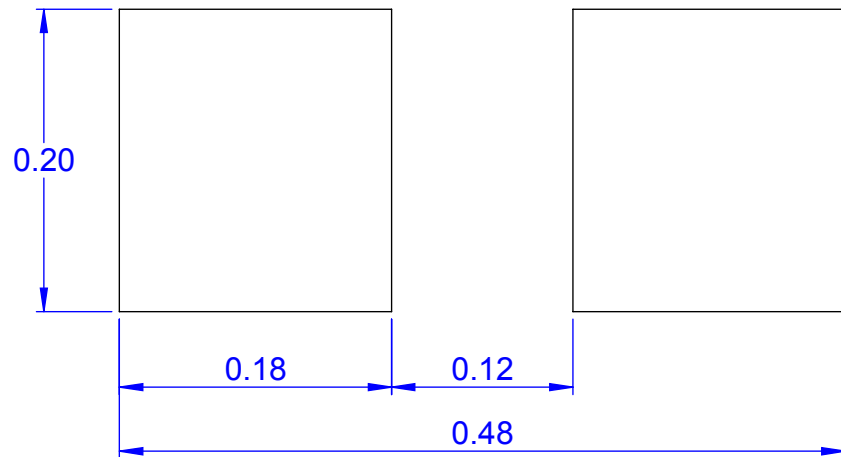

PCB DIMENSIONS ARE PRESENTED ONLY AS A GUIDELINE. DESIGNERS SHOULD USE THEIR OWN KNOWLEDGE BASE WHEN DESIGNING THE PCB.

STRUCTURE

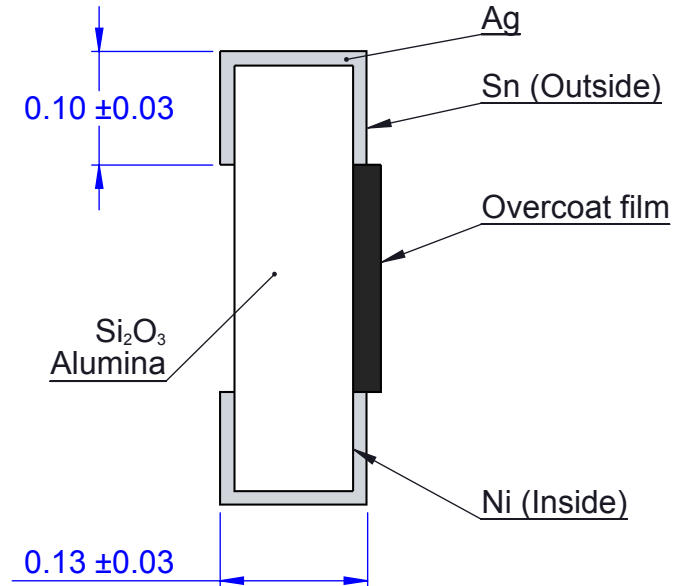

NOTES:

1. DIMENSIONS IN mm.
2. TERMINATION: Tin (Sn).
3. Pb-FREE AND HALOGEN FREE.

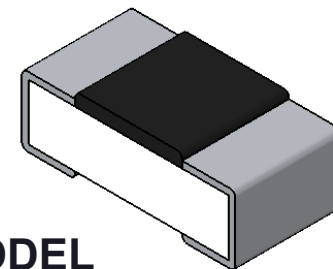

MODEL

APPROVALS	DATE	TopLine®			
DRAWN T. Au	08/03/12				
ENG M. Hart	08/03/12	TITLE SR01005-W8P2			
MFG		SMT RESISTOR			
QA		SCALE	SIZE	DRAWING NO.	REV
CUST			A	120151	A
REVISED		DO NOT SCALE DRAWING			SHEET 1 OF 2

W8P2 CARRIER TAPE DIMENSION

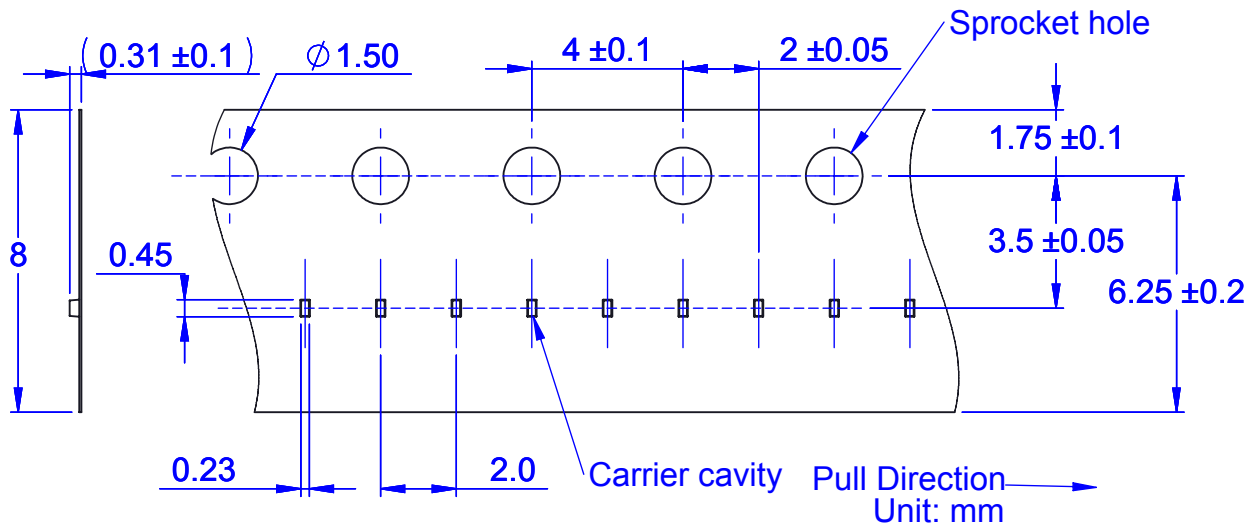

W8P2 TAPE PART NUMBER SYSTEM

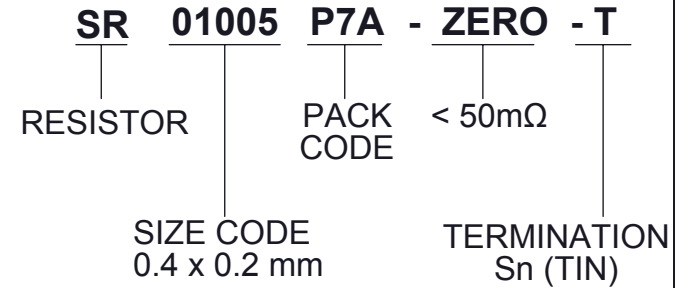

NOTE: For dummy resistor replace ZERO with blank

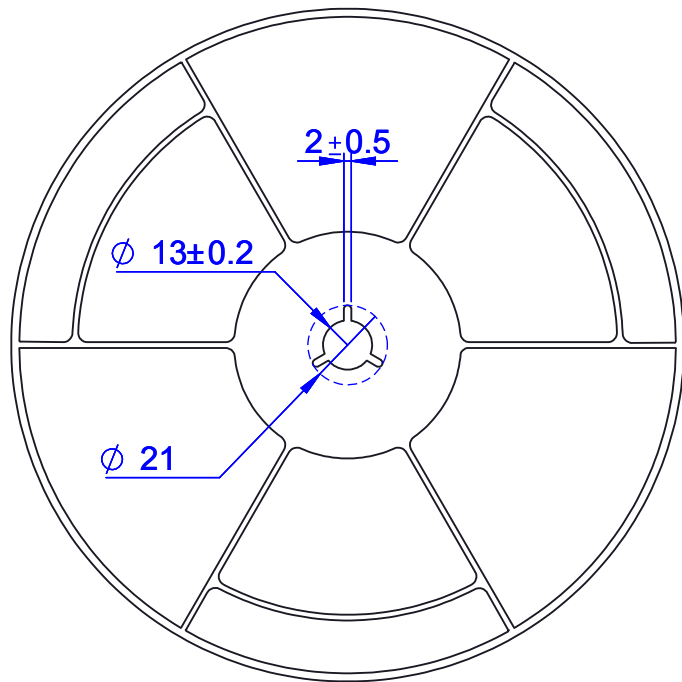

REEL DIMENSIONS

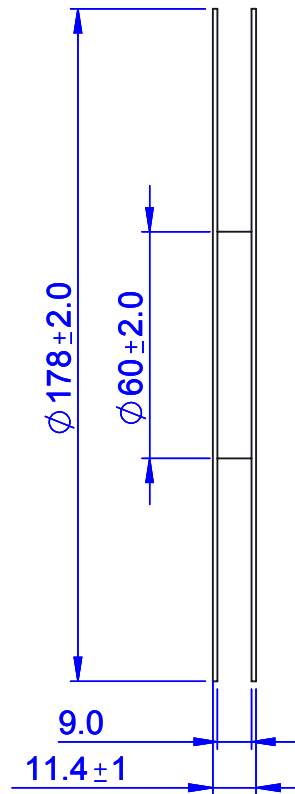

PACK CODE		
CODE	QTY	PACKAGE
P7A	20,000	REEL
P7B	10,000	REEL
P7C	5,000	REEL
P4A	1,000	REEL

APPROVALS		DATE	 SR01005-W8P2 SMT RESISTOR			
DRAWN	T. Au	08/03/12				
ENG	M. Hart	08/03/12	TITLE			
MFG			SCALE	SIZE	DRAWING NO.	REV
QA				A	120151	A
CUST			DO NOT SCALE DRAWING			SHEET 2 OF 2
REVISED						