

### TOP VIEW

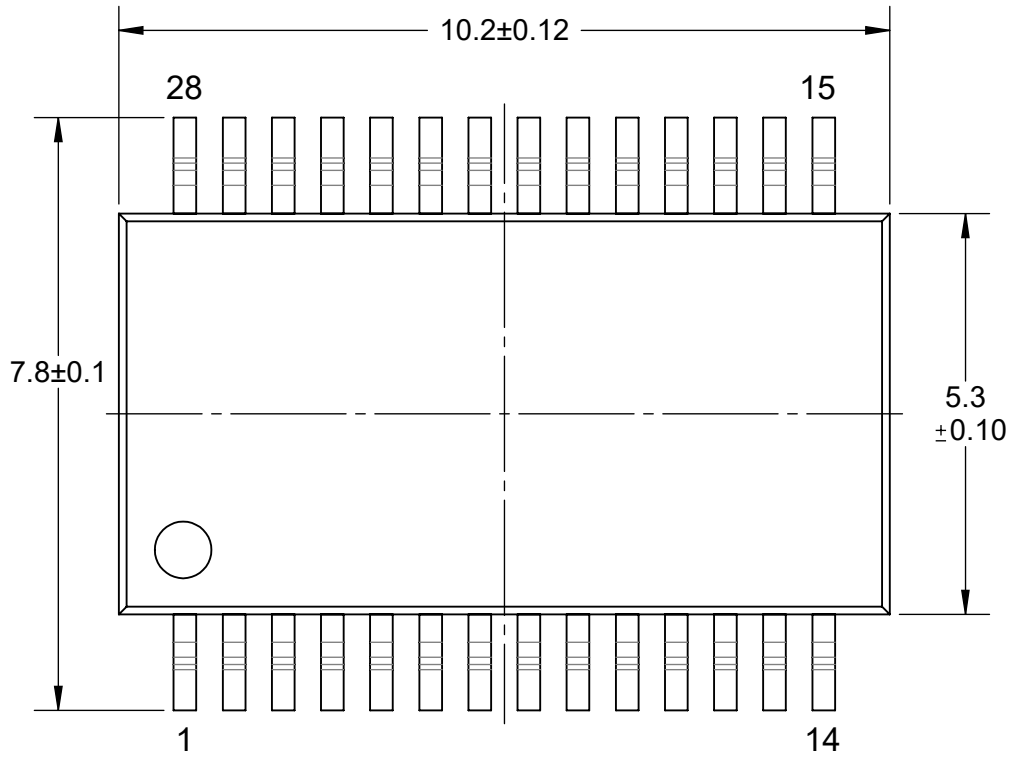

### DETAIL A

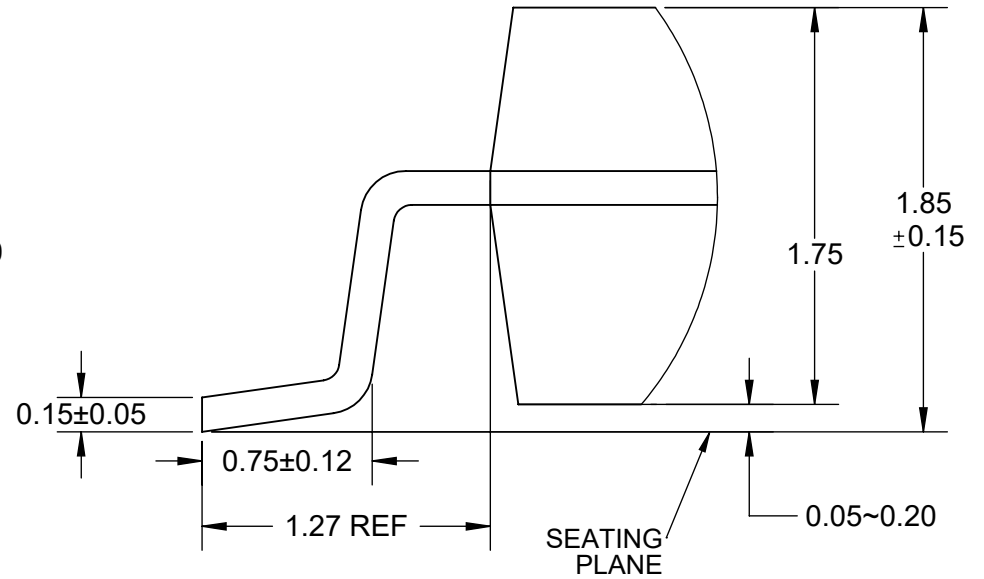

### SIDE VIEW

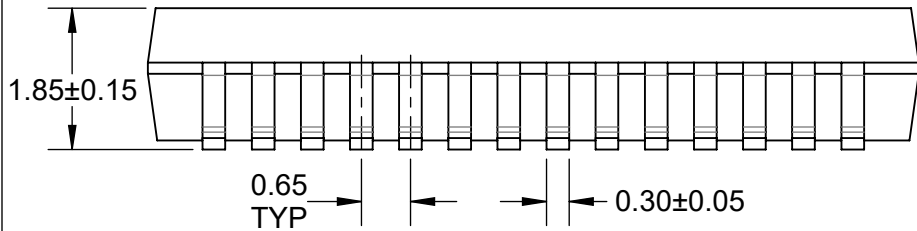

### END VIEW

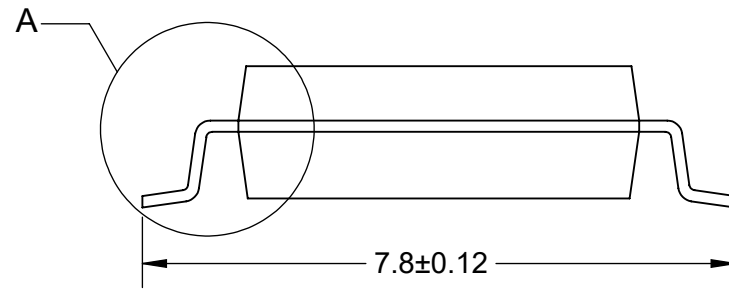

Notes: (Unless Otherwise Specified)

1. DIMENSIONS ARE IN mm.
2. SEE DAISY CHAIN JUMPER DIAGRAMS (PAGE 2).
3. SEE PART NUMBER CONFIGURATION (PAGE 3).
4. RECOMMENDED PC BOARD LAYOUT PATTERN (PAGE 5).

APPROVALS	DATE	<b>TopLine®</b>			
DRAWN T. Au	12/29/2025				
ENG M. Hart	12/29/2025	TITLE SSOP28 OUTLINE PACKAGE			
MFG		SCALE	SIZE	DRAWING NO.	REV
QA		10:1	A	122809	A
CUST		DO NOT SCALE DRAWING			SHEET 1 OF 6
REVISED					

# INTERNAL WIRING CIRCUIT (JUMPER) DAISY CHAIN PART NUMBER SUFFIX TOP VIEW

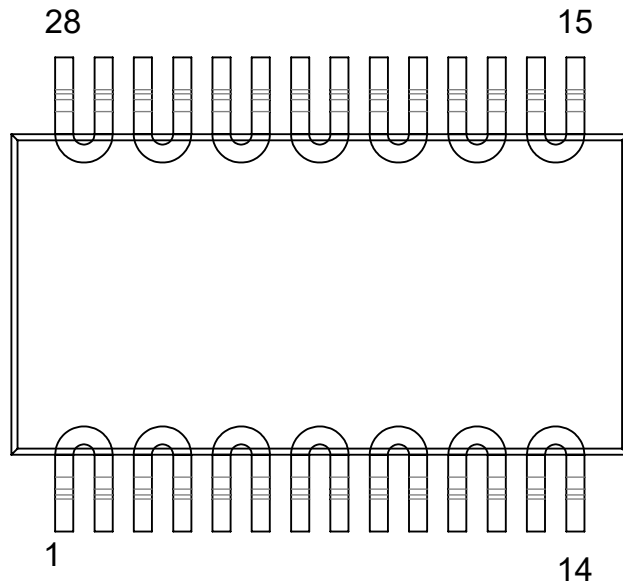

**DE**  
DAISY CHAIN  
EVEN

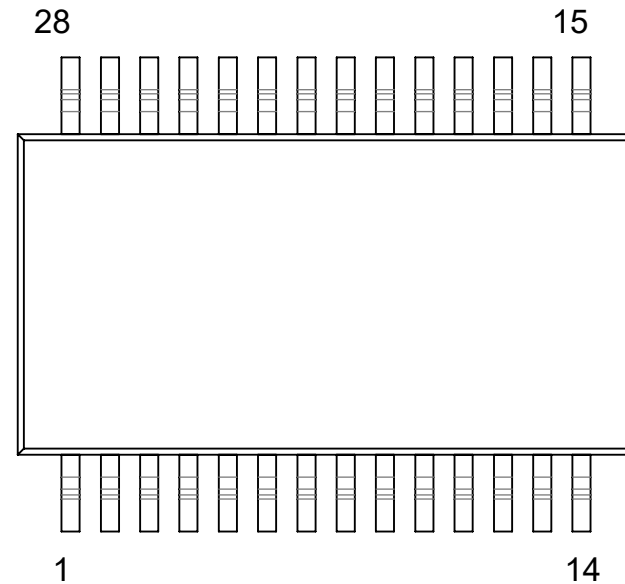

**ISO**  
ISOLATED CIRCUIT  
NO INTERNAL  
CONNECTIONS

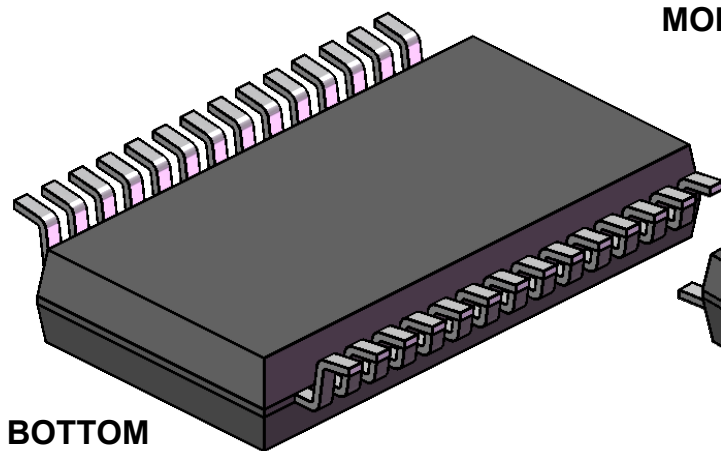

**BOTTOM**

**MODEL**

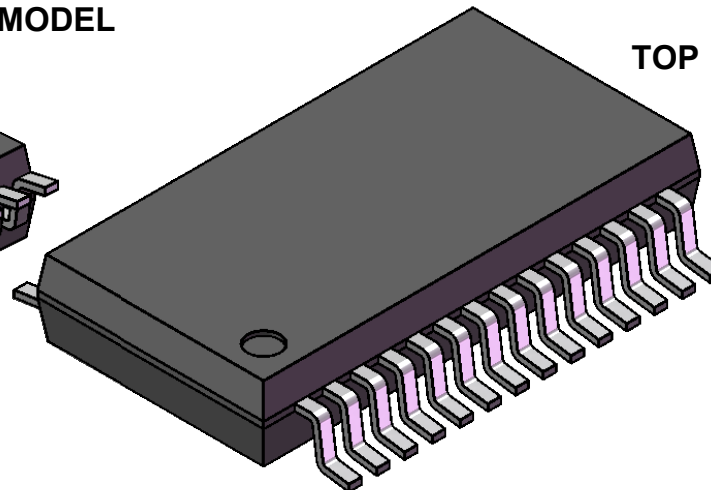

**TOP**

<b>TopLine®</b>			
TITLE		SSOP28 OUTLINE PACKAGE	
SCALE	SIZE	DRAWING NO.	REV
10:1	A	122809	A
DO NOT SCALE DRAWING			SHEET 2 OF 6

## PART NUMBERING SYSTEM

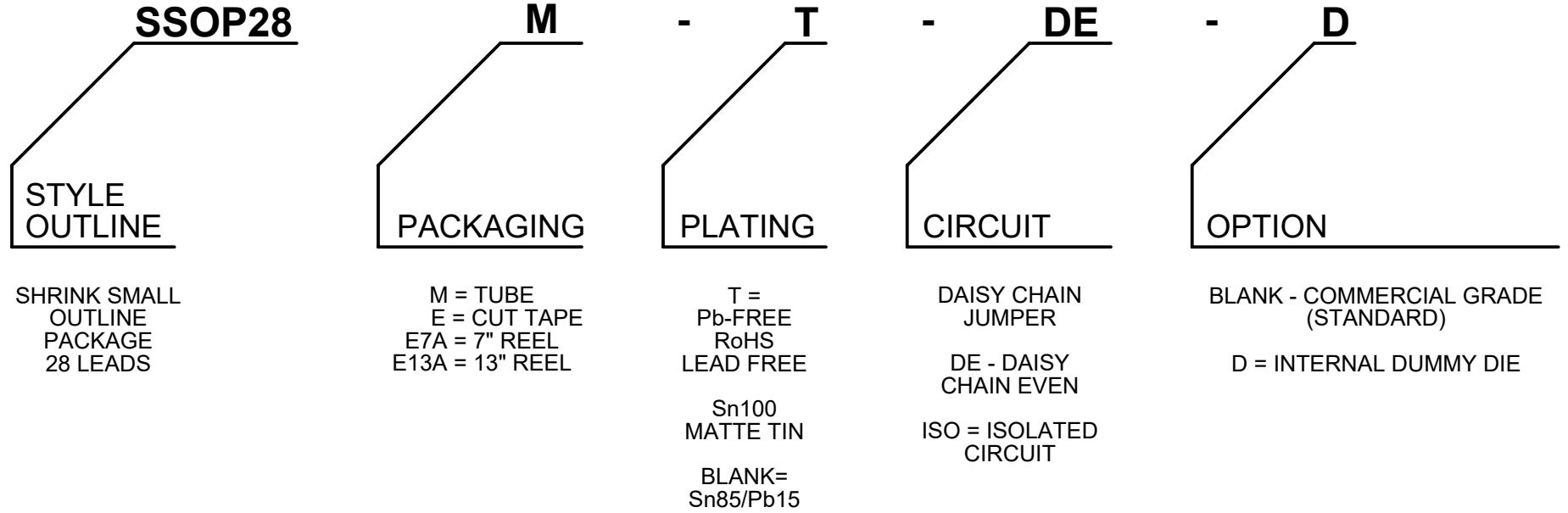

PART NUMBER	SHORTED PINS	NOTES	RoHS Pb-FREE	MSL LEVEL
SSOP285-T	N/A	DUMMY	YES	1
SSOP28M25-T-ISO	NONE	FULLY ISOLATED	YES	1
SSOP28M25-T-DE-D	1~2, 3~4, 5~6, 7~8, 9~10, 11~12, 13~14, 15~16, 17~18, 19~20, 21-22, 23-24, 25-26, 27-28	DAISY CHAIN	YES	1
SSOP28E25-T-DE-D	1~2, 3~4, 5~6, 7~8, 9~10, 11~12, 13~14, 15~16, 17~18, 19~20, 21-22, 23-24, 25-26, 27-28	DAISY CHAIN	YES	1

<b>TopLine®</b>			
TITLE SSOP28 OUTLINE PACKAGE			
SCALE NONE	SIZE A	DRAWING NO. 122809	REV A
DO NOT SCALE DRAWING			SHEET 3 OF 6

# TAPE SPECIFICATION SSOP28 SURFACE MOUNT DEVICE

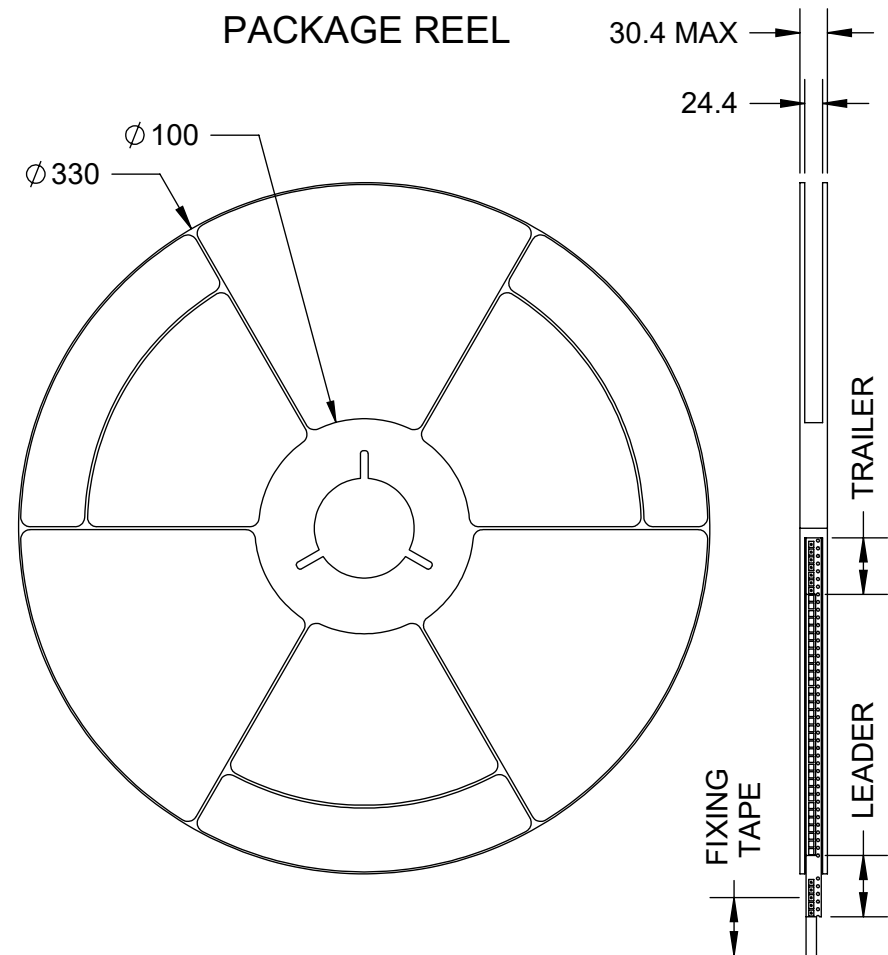
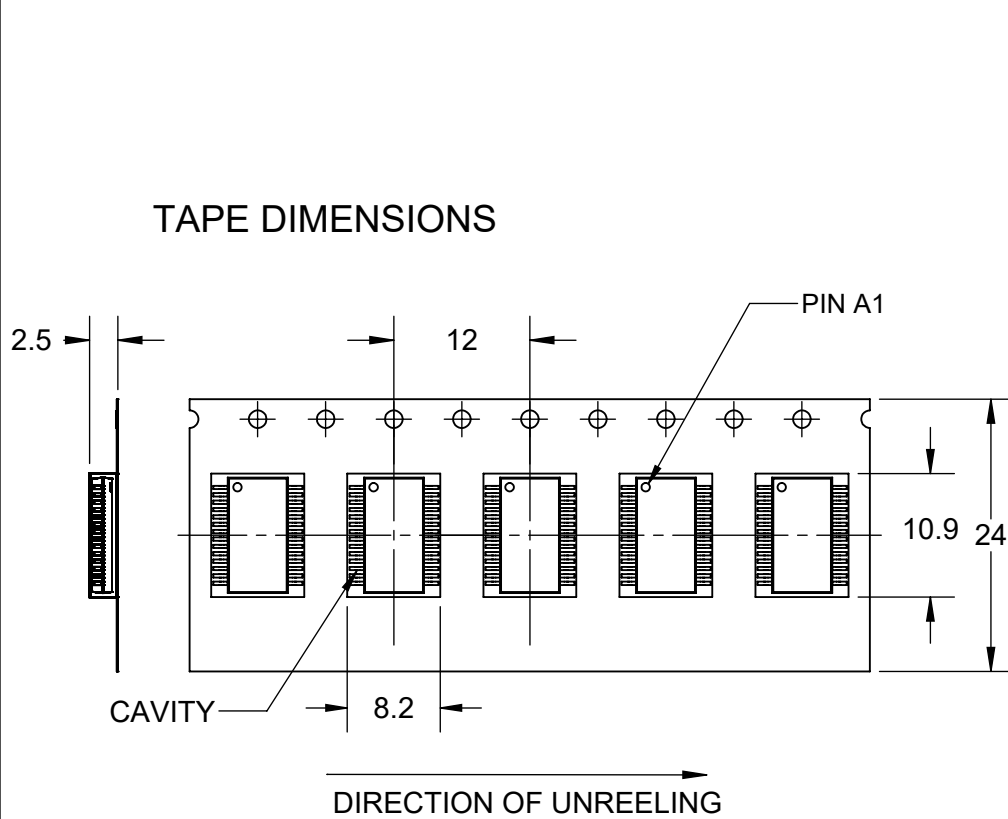

24mm TAPE  
1000 PCS

# PRELIMINARY

ALL DIMENSIONS: mm.

<b>TopLine®</b>			
TITLE SSOP28 OUTLINE PACKAGE			
SCALE 3:2	SIZE A	DRAWING NO. 122809	REV A
DO NOT SCALE DRAWING			SHEET 4 OF 6

# PCB BOARD LAND PATTERN

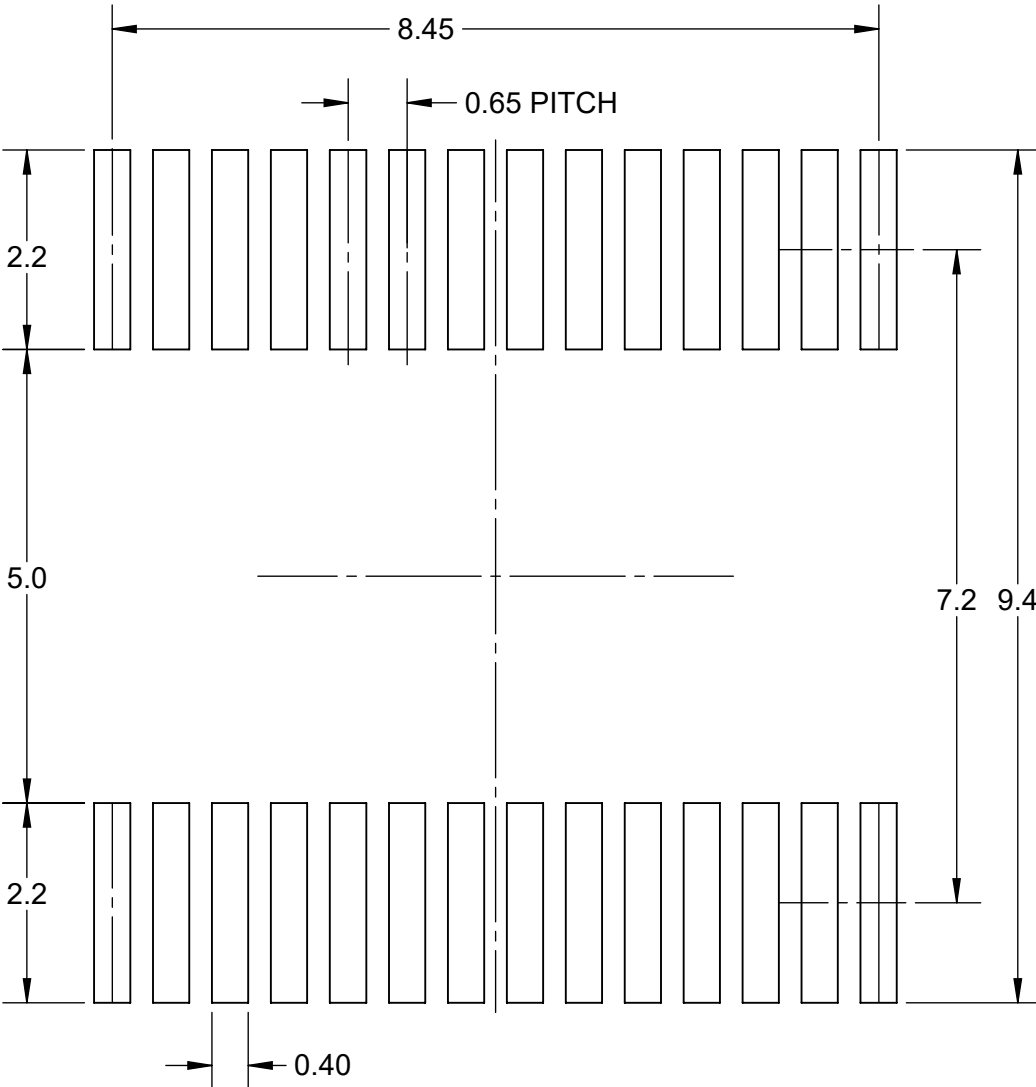

Notes: (Unless Otherwise Specified)

1. DIMENSIONS ARE IN mm.
2. PCB BOARD DIMENSIONS ARE PRESENTED ONLY AS A GUIDELINE.
3. DESIGNERS SHOULD USE THEIR OWN EXPERIENCE WHEN DESIGNING PCB.

<b>TopLine®</b>			
TITLE		SSOP28 OUTLINE PACKAGE	
SCALE	SIZE	DRAWING NO.	REV
12:1	A	122809	A
DO NOT SCALE DRAWING			SHEET 5 OF 6

## LEAD FREE REFLOW PROFILE OF SMD PACKAGE

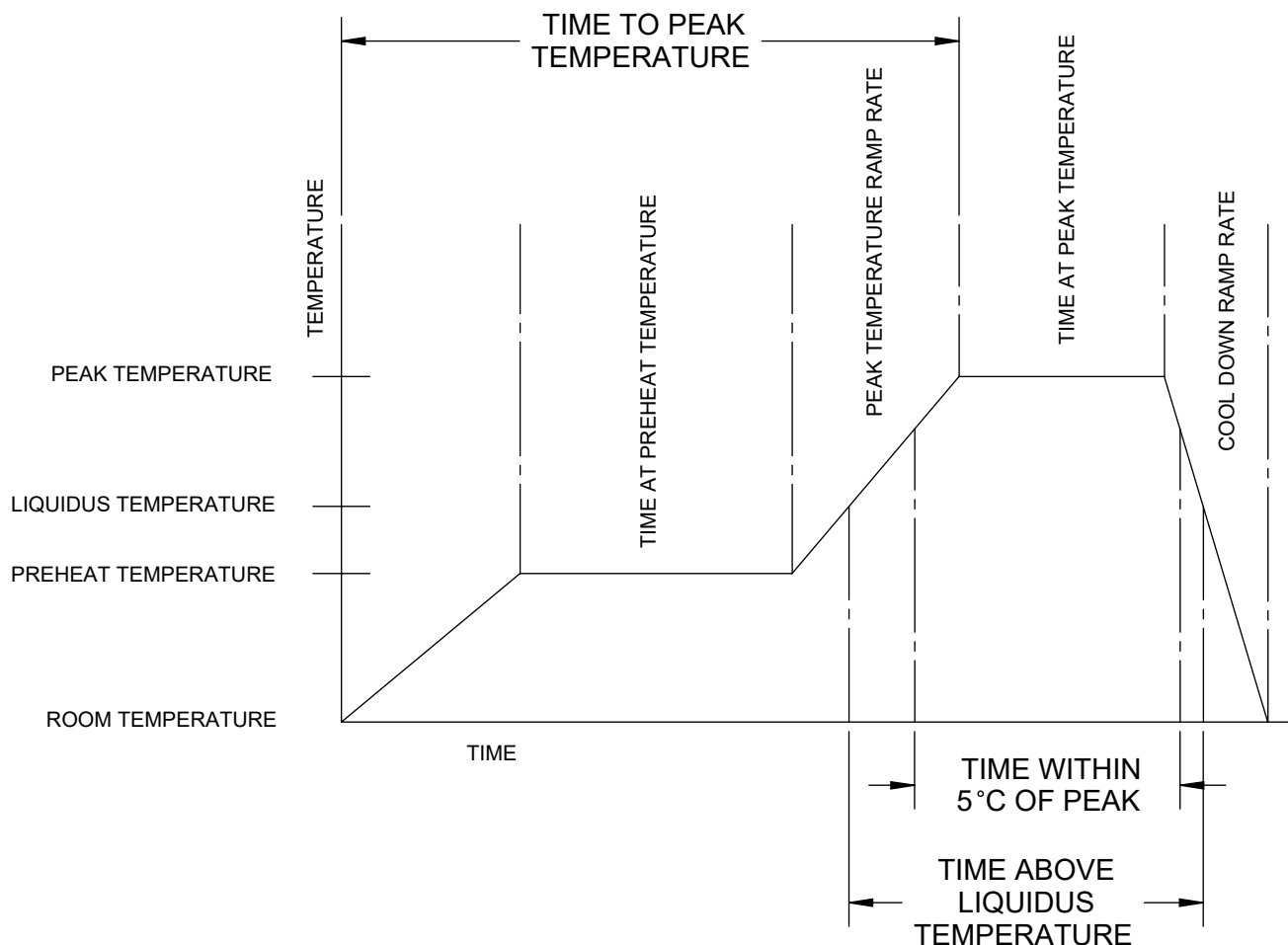

DESCRIPTION	REQUIREMENT
AVERAGE PREHEAT RAMP RATE	3°C /SECOND MAXIMUM
PREHEAT TEMPERATURE	150°C MINIMUM, 200°C MAXIMUM
PREHEAT TIME	60 TO 80 SECONDS
RAMP TO PEAK	3°C /SECOND MAXIMUM
TIME OVER LIQUIDUS (217°C)	60 TO 150 SECONDS
PEAK TEMPERATURE	260°C +0/-5°C
TIME WITHING 5°C OF PEAK	20 TO 40 SECONDS
RAMP - COOL DOWN	6°C /SECONDS MAXIMUM
TIME 25°C TO PEAK	6 MINUTES MAXIMUM

**TopLine®**

TITLE                      SSOP28  
OUTLINE PACKAGE

SCALE NONE	SIZE A	DRAWING NO. 122809	REV A
---------------	-----------	-----------------------	----------

DO NOT SCALE DRAWING

SHEET 6 OF 6