

FLAT LEAD OUTLINE

TOP VIEW

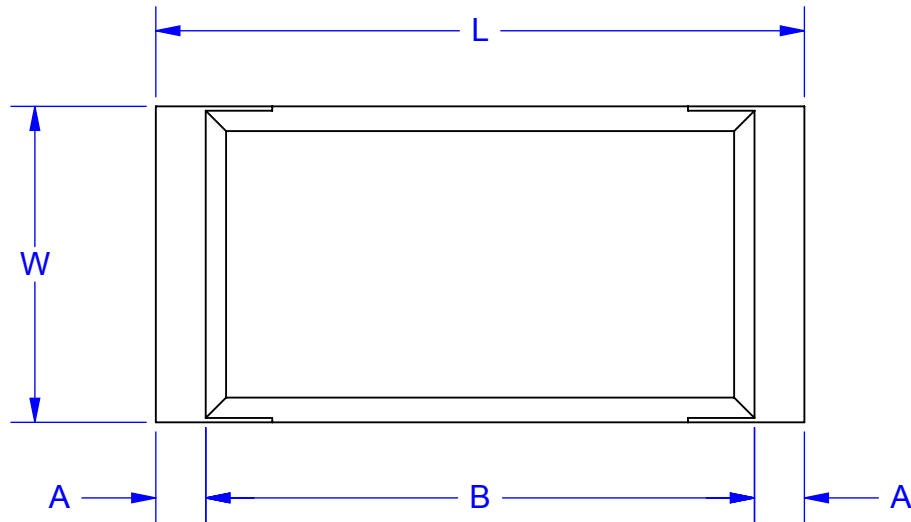

DIMENSION TABLE	
PART SERIES	SMB-F
CROSS REF	-
JEDEC REF	DO-214AA
L	5.0 - 5.4
W	3.2 - 3.6
H	1.7 - 1.9
A	0.4 TYP
B	4.2 - 4.6
C	0.8 TYP
D	3.4 - 3.9
b	0.2
SPACER - REF	FM20N-B

SIDE VIEW

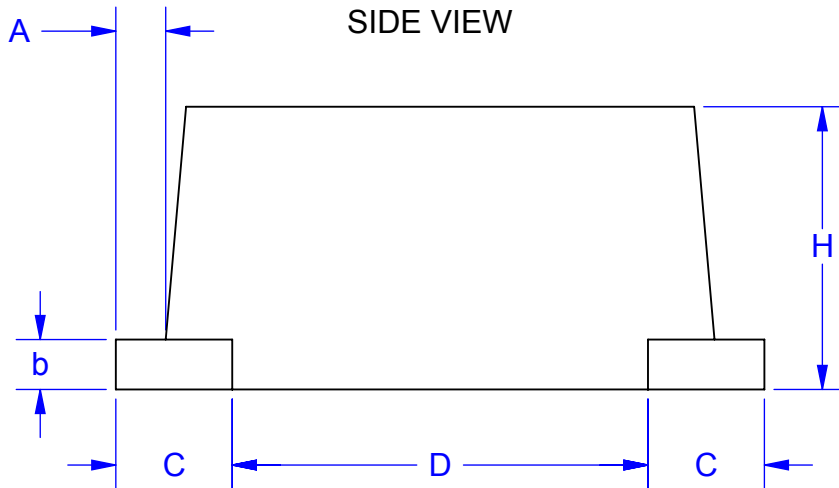

END VIEW

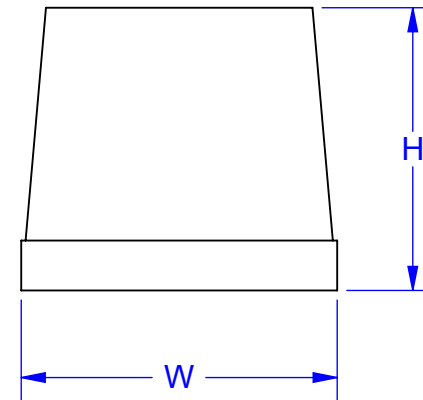

Notes: (Unless Otherwise Specified).

- 1) DIMENSIONS IN mm.
- 2) SEE SPACER DIAGRAMS (PAGE 2).
- 3) SEE PART NUMBER CONFIGURATION (PAGE 4).
- 4) RECOMMENDED PC BOARD LAYOUT PATTERN (PAGE 6).
- 5) MOUNTING POSITION: ANY (NON-POLARIZED).
- 6) CASE: UL94-V RATED FLAME RETARDANT.

APPROVALS	DATE				
DRAWN T.Au	12/11/13				
ENG M. Hart	12/11/13	TITLE SMBF FLAT LEAD SPACER			
MFG					
QA		SCALE 22:1	SIZE A	DRAWING NO. 121304	REV A
CUST		DO NOT SCALE DRAWING			SHEET 1 OF 7
REVISED					

INTERNAL WIRING CIRCUIT
PART NUMBER SUFFIX
TOP VIEW

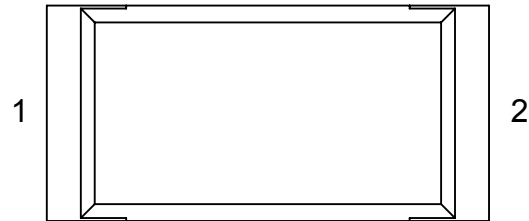

ISO
NO CONNECTION
FULLY ISOLATED
NON-CONDUCTIVE SPACER

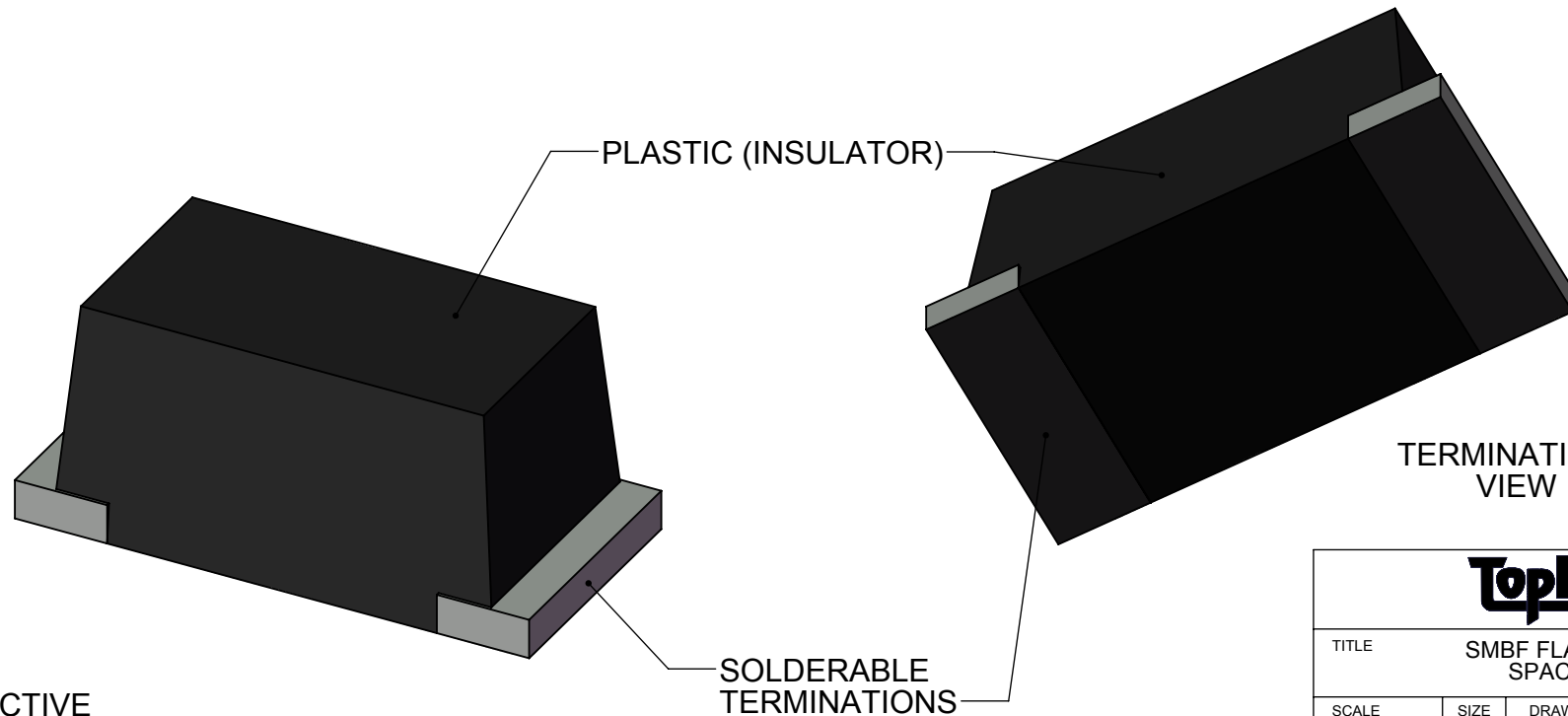

PERSPECTIVE
VIEW

TERMINATIONS
VIEW

TopLine®			
TITLE		SMBF FLAT LEAD SPACER	
SCALE	SIZE	DRAWING NO.	REV
20:1	A	121304	A
DO NOT SCALE DRAWING			SHEET 2 OF 7

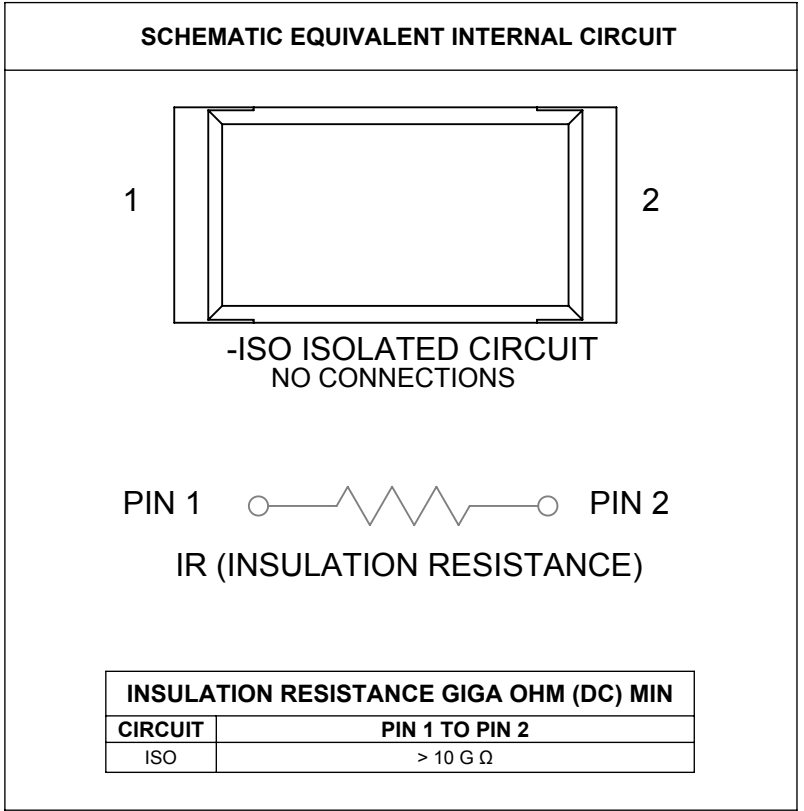
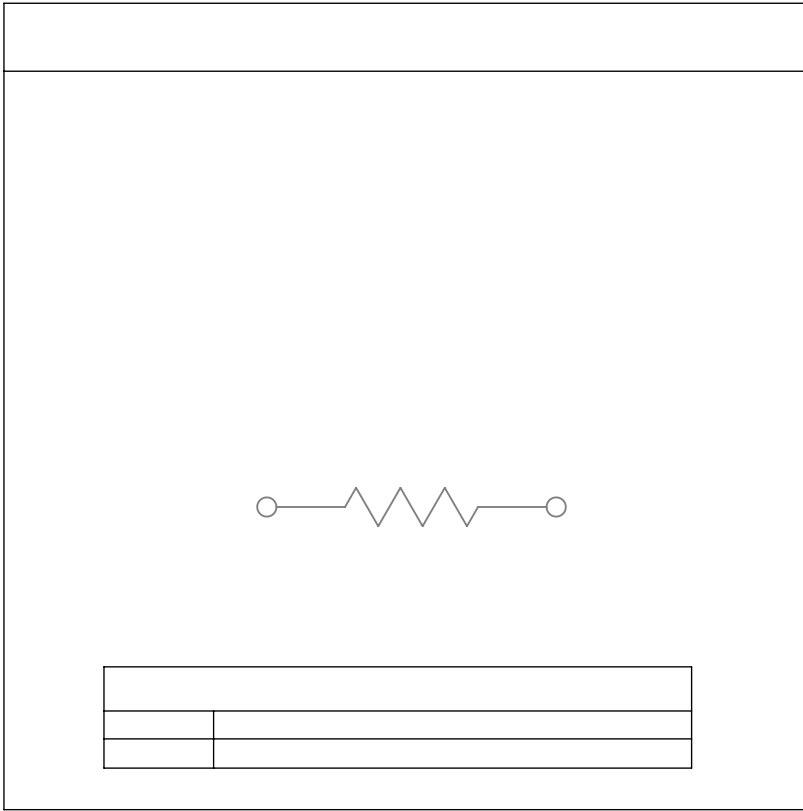

MAXIMUM ELECTRICAL (DC) RATING	PART TYPE
V _R WORKING VOLTAGE	1000V
V _F FORWARD @ RATED CURRENT	< 0.2V
I _o FORWARD CURRENT	2.0 A
I _{FSM} FORWARD SURGE CURRENT	70 A
I _r REVERSE CURRENT	2.0 A
C _J JUNCTION CAPACITANCE	30 pF

THERMAL RESISTANCE	PART TYPE
JUNCTION TO AMBIENT (T _a =25°) R _{th(j-a)}	12°C/W

TEMPERATURE RATING	
JUNCTION TEMP T _J	150°C
STORAGE TEMP T _{stg}	-65°C TO 150°C
PEAK REFLOW TEMP T _{reflow} 10 SECONDS	260°C

TopLine®			
TITLE		SMBF FLAT LEAD SPACER	
SCALE	SIZE	DRAWING NO.	REV
15:1	A	121304	A
DO NOT SCALE DRAWING			SHEET 3 OF 7

PART NUMBERING SYSTEM

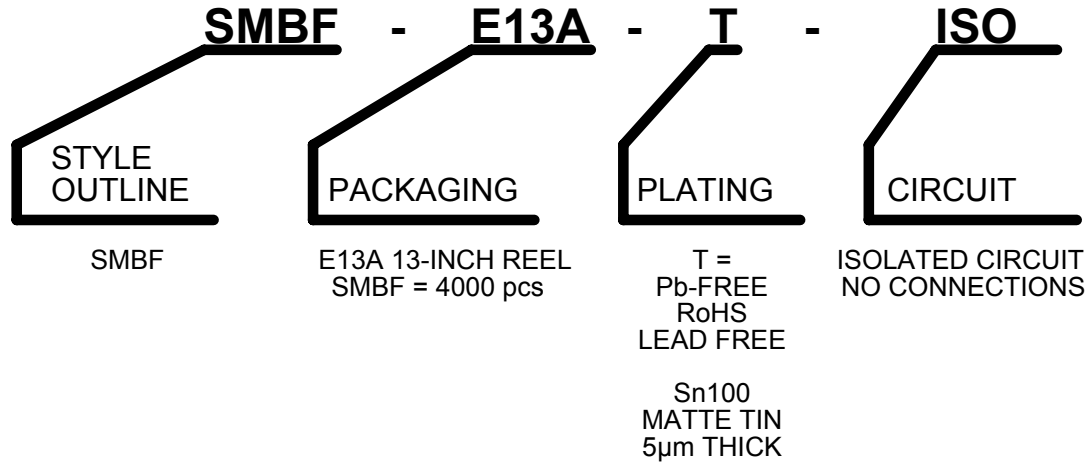

OUTLINE	REEL QTY	NOTES	RoHS	MSL LEVEL	HALOGEN FREE	APPLICATION	TOP MARK	REF	DP#
SMBF-E13A-T-DISO	4000	OPEN CIRCUIT	YES	1	NO	SPACER	NC	FM20N-B	130472

TopLine®

TITLE SMBF FLAT LEAD SPACER

SCALE 25:1	SIZE A	DRAWING NO. 121304	REV A
---------------	-----------	-----------------------	----------

DO NOT SCALE DRAWING

SHEET 4 OF 7

TAPE SPECIFICATION
SURFACE MOUNT DEVICE

7 AND 13 INCH PACKAGE REEL

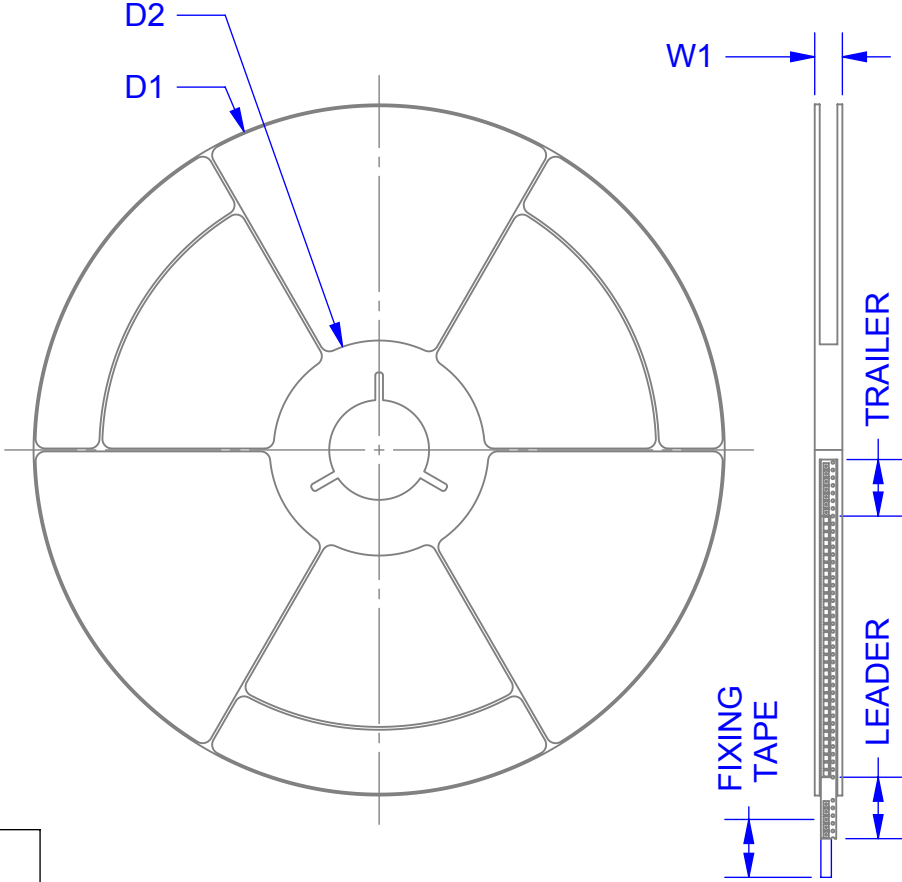
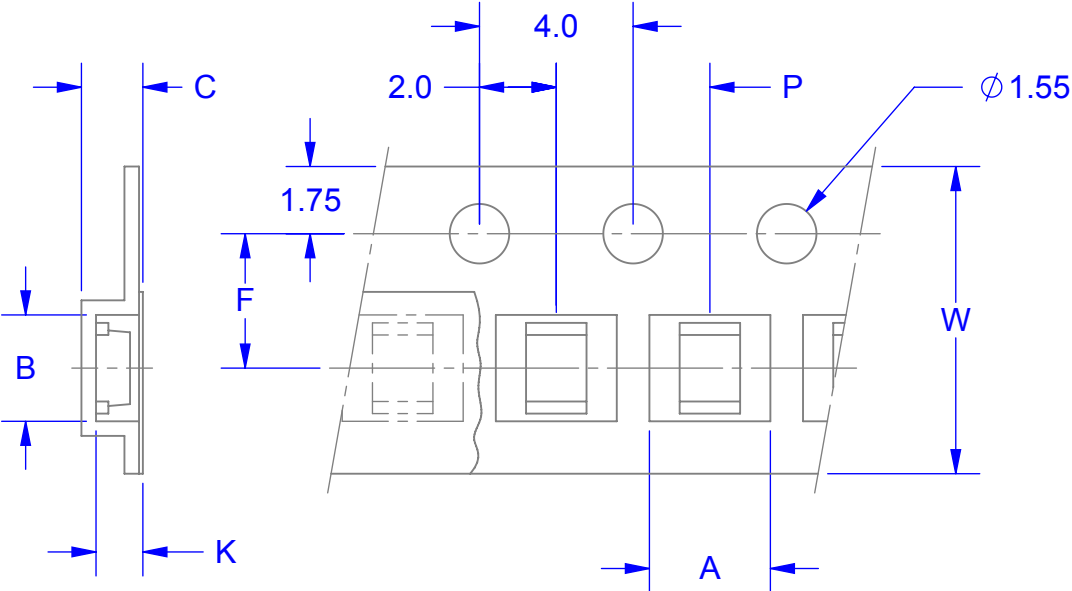

DIRECTION OF UNREELING →

PARTS ARE NON-POLARIZED

TAPE AND REEL DIMENSIONS		E7A 7-INCH	E13A 13-INCH
	SYMBOL	SMBF	SMBF
TAPE WIDTH	W	12	12
PITCH OF COMPONENTS	P	8	8
POCKET WIDTH	A	3.81	3.81
POCKET LENGTH	B	5.74	5.74
POCKET DEPTH	K	2.24	2.24
CARRIER THICKNESS	C	2.47	2.47
REEL DIAMETER	D1	330	330
HUB DIAMETER	D2	50	50
PUNCH HOLE POSITION	F	5.5	5.5
MAX REEL WIDTH	W1	18	18
REF (SPACER)	-	FM20N-B	FM20N-B
QUANTITY (PSC)	-	500	4000

ALL DIMENSIONS IN mm.

TopLine®			
TITLE		SMBF FLAT LEAD SPACER	
SCALE	SIZE	DRAWING NO.	REV
1:1	A	121304	A
DO NOT SCALE DRAWING			SHEET 5 OF 7

PC BOARD LAND PATTERN

PCB PAD DIMENSIONS	
SYMBOL	SMBF
A	3.60
B	1.50
C	3.00
D	6.00
∅	4.5
L	5.0 - 5.4
REF SPACER	FM20N-B
REF SPACER	SMBF-ISO

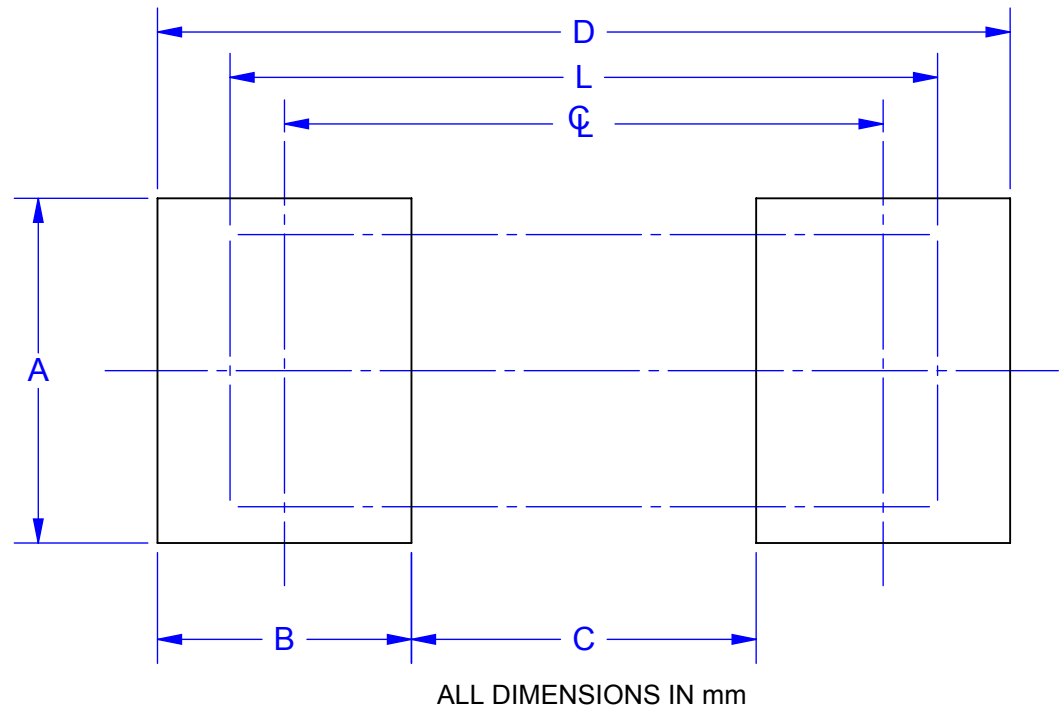

Notes: (Unless Otherwise Specified).

1) DIMENSIONS IN mm.

2) PCB BOARD DIMENSIONS ARE PRESENTED ONLY AS A GUIDELINE.
DESIGNERS SHOULD USE THEIR OWN EXPERIENCE WHEN DESIGNING PCB.

TopLine[®]			
TITLE		SMBF FLAT LEAD SPACER	
SCALE	SIZE	DRAWING NO.	REV
24:1	A	121304	A
DO NOT SCALE DRAWING			SHEET 6 OF 7

LEAD FREE REFLOW PROFILE OF SMD PACKAGE

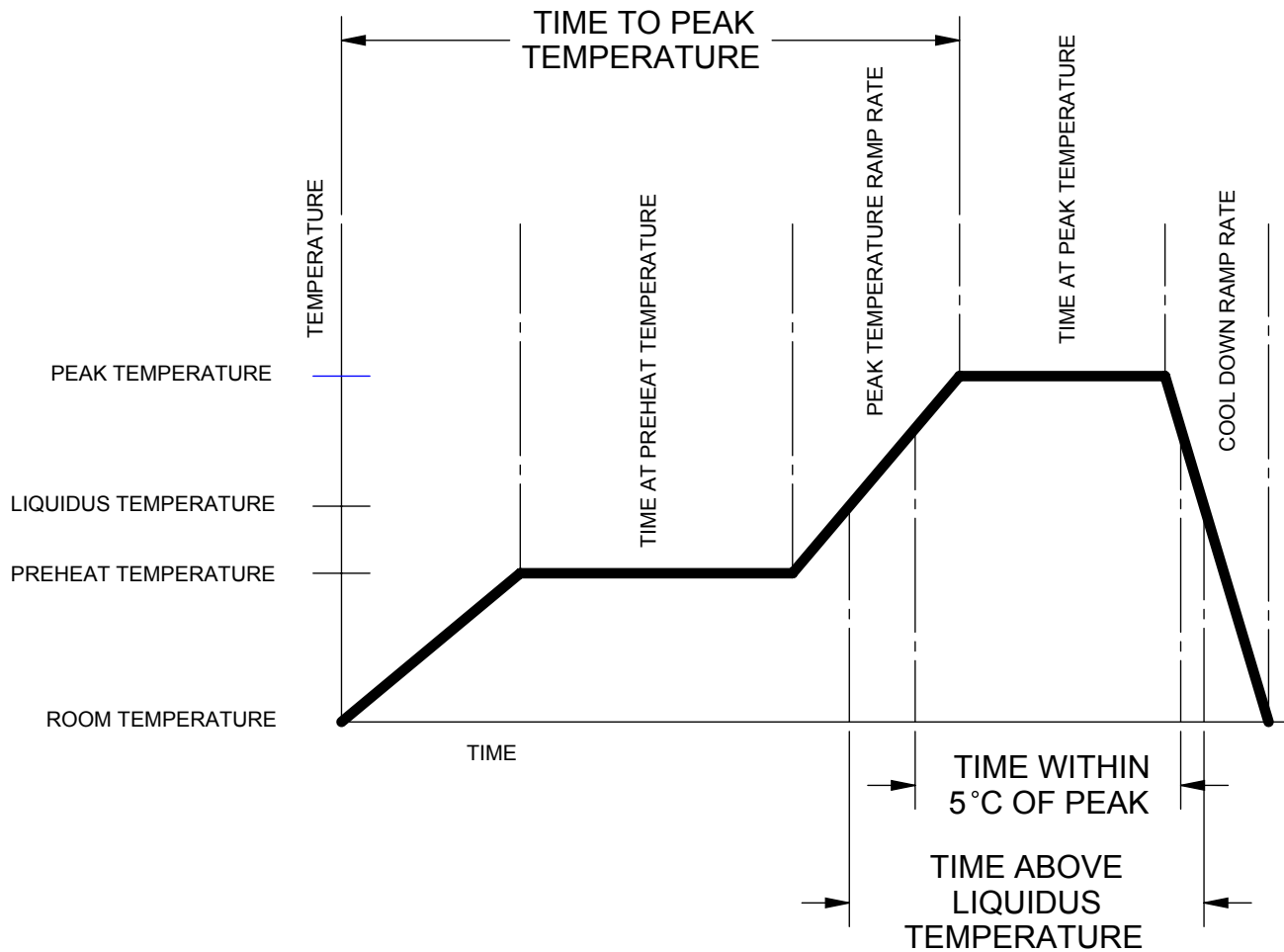

DESCRIPTION	REQUIREMENT
AVERAGE PREHEAT RAMP RATE	3°C /SECOND MAXIMUM
PREHEAT TEMPERATURE	150°C MINIMUM, 200°C MAXIMUM
PREHEAT TIME	60 TO 120 SECONDS
RAMP TO PEAK	3°C /SECOND MAXIMUM
TIME OVER LIQUIDUS (217°C)	60 TO 260 SECONDS
PEAK TEMPERATURE	260°C +0/-5°C
TIME WITHING 5°C OF PEAK	10 TO 30 SECONDS
RAMP - COOL DOWN	6°C /SECONDS MAXIMUM
TIME 25°C TO PEAK	6 MINUTES MAXIMUM

TopLine®			
TITLE		SMBF FLAT LEAD SPACER	
SCALE	SIZE	DRAWING NO.	REV
1:1	A	121304	A
DO NOT SCALE DRAWING			SHEET 7 OF 7