

**TOP**

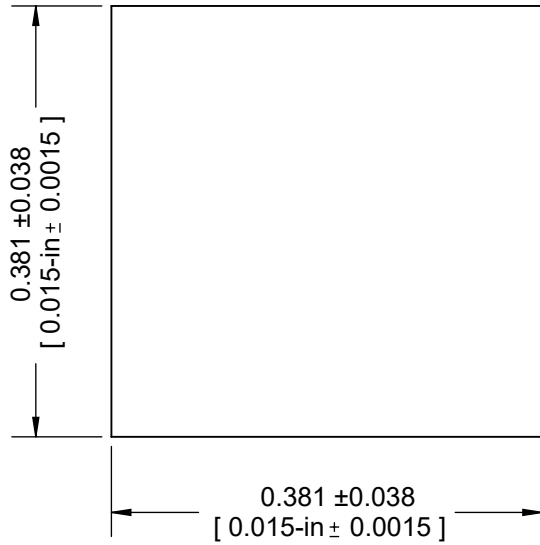

**SIDE**

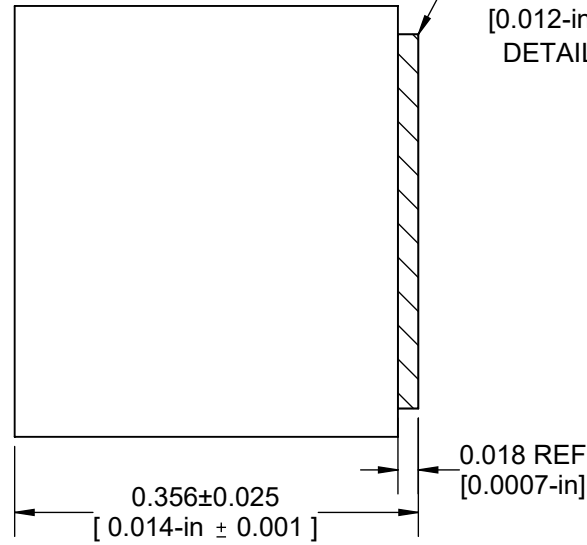

**BOTTOM**

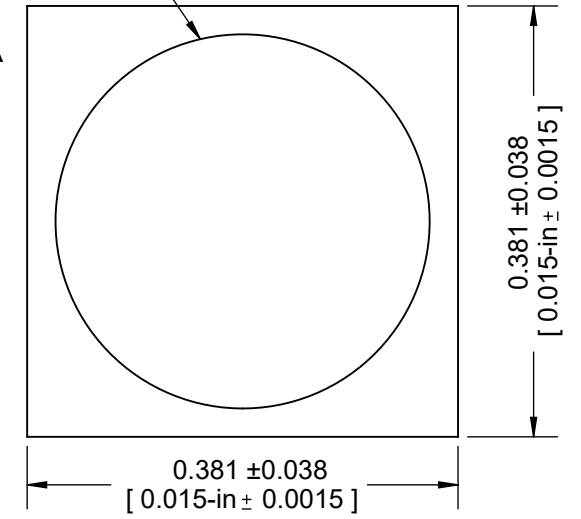

NOTE 9

**MODELS**

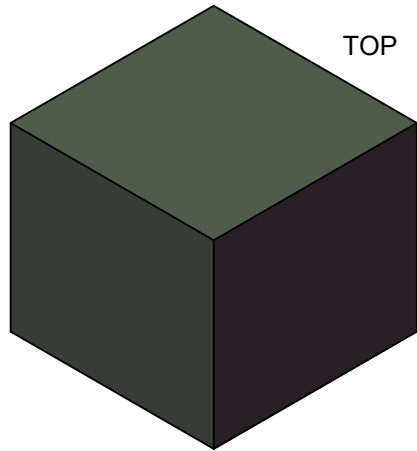

TOP

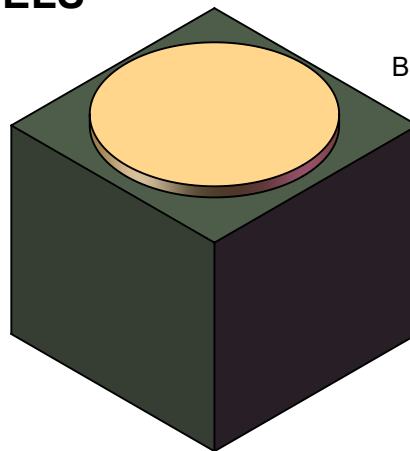

BOTTOM

**PAD DETAIL A  
Not to Scale**

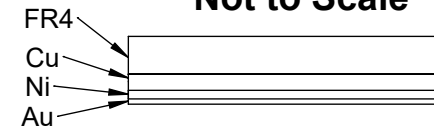

**METALLIZATION  
THICKNESS**

Cu	0.018mm
Ni	4.0µm ± 1.5µm
Au	0.05µm ± 0.02µm

Notes: (Unless Otherwise Specified).

- 1) DIMENSIONS: MM [INCH].
- 2) PAD: COPPER 0.0007-INCH (0.018mm) THICK.
- 3) PLATING: ENIG (ELECTROLESS-NICKEL IMMERSION GOLD)
- 4) NO MARKINGS.
- 5) BOTTOM TERMINAL.
- 6) NO SOLDERMASK.
- 7) LEAD FREE (Pb-FREE)
- 8) BODY: FR4 OR EQUIVALENT.
- 9) TOTAL HEIGHT (INCLUDING PAD) 0.381mm (15 MIL) MAXIMUM.

APPROVALS		DATE				
DRAWN	T.Au	03/09/2023				
ENG	M. Hart	03/09/2023	TITLE SSL01501514-R-G SOLDERABLE SPACER			
MFG			SCALE	SIZE	DRAWING NO.	REV
QA			30:1	A	151514	A
CUST			DO NOT SCALE DRAWING			SHEET 1 OF 5
REVISED						

# PC BOARD LAND PATTERN

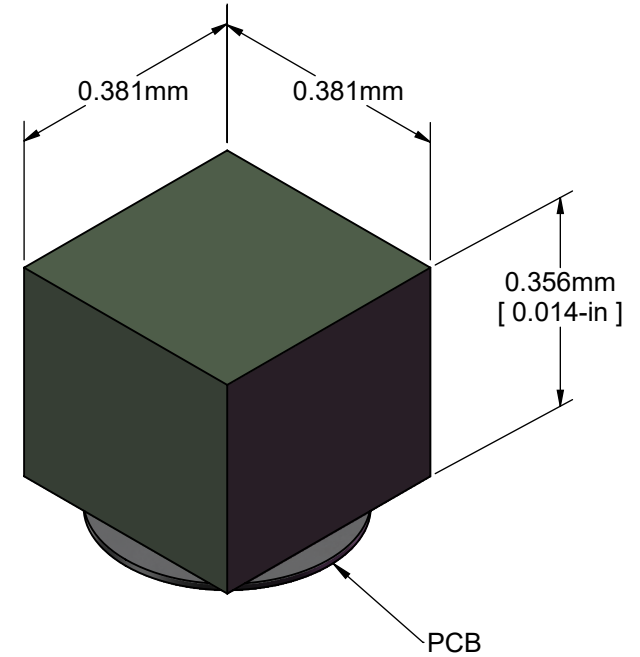
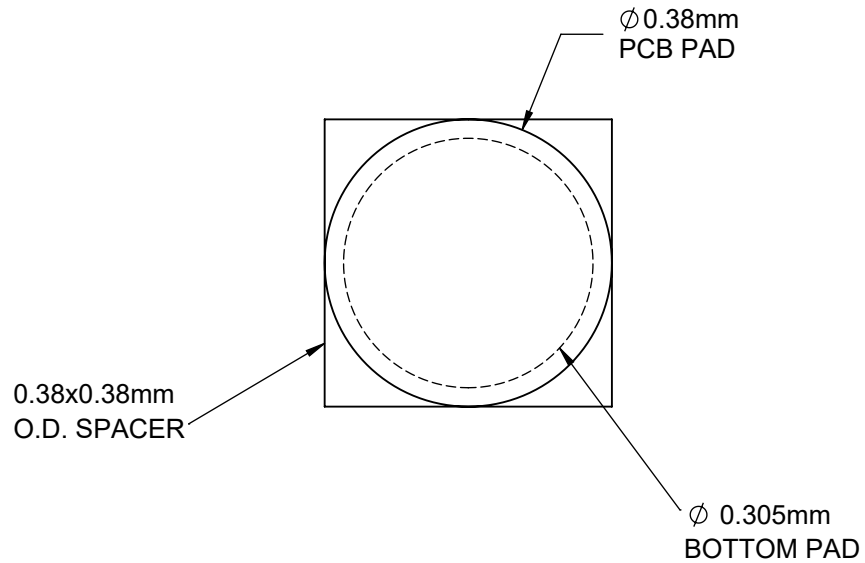

MODEL

Notes: (Unless Otherwise Specified).

1) DIMENSIONS mm [Inch].

2) PCB BOARD DIMENSIONS ARE PRESENTED ONLY AS A GUIDELINE.  
DESIGNERS SHOULD USE THEIR OWN EXPERIENCE WHEN DESIGNING PCB.

<b>TopLine<sup>®</sup></b>			
TITLE		SSL01501514-R-G SOLDERABLE SPACER	
SCALE	SIZE	DRAWING NO.	REV
40:1	A	151514	A
DO NOT SCALE DRAWING			SHEET 2 OF 5

## PART NUMBERING SYSTEM

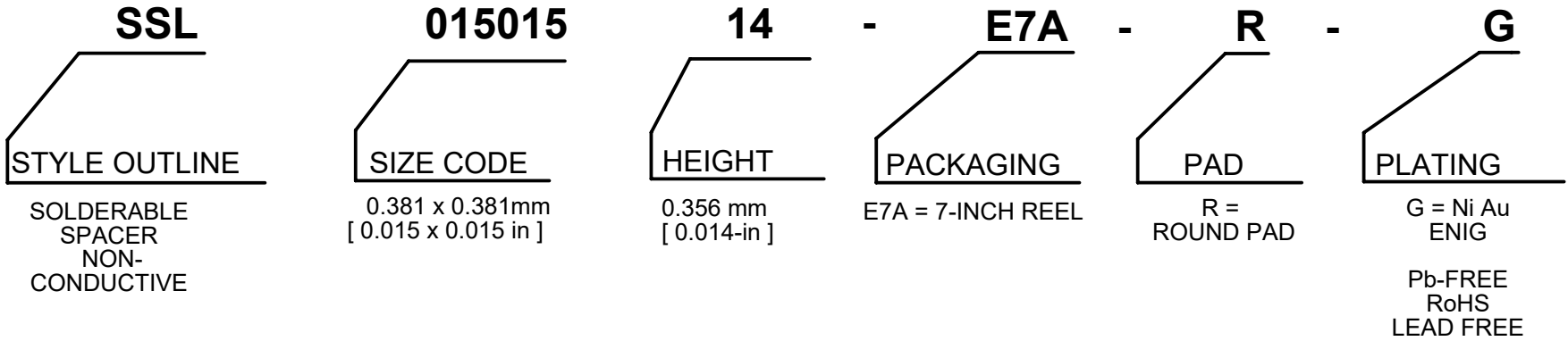

PART NUMBER	PACKAGE QTY	RoHS	PACK	APPLICATION	TOP MARK	DWG
SSL01501514E7A-R-G	3000	YES	REEL	SPACER	NONE	151514

<b>TopLine®</b>			
TITLE SSL01501514-R-G SOLDERABLE SPACER			
SCALE NONE	SIZE A	DRAWING NO. 151514	REV A
DO NOT SCALE DRAWING			SHEET 3 OF 5

## TAPE SPECIFICATION SURFACE MOUNT DEVICE

## 7-INCH REEL

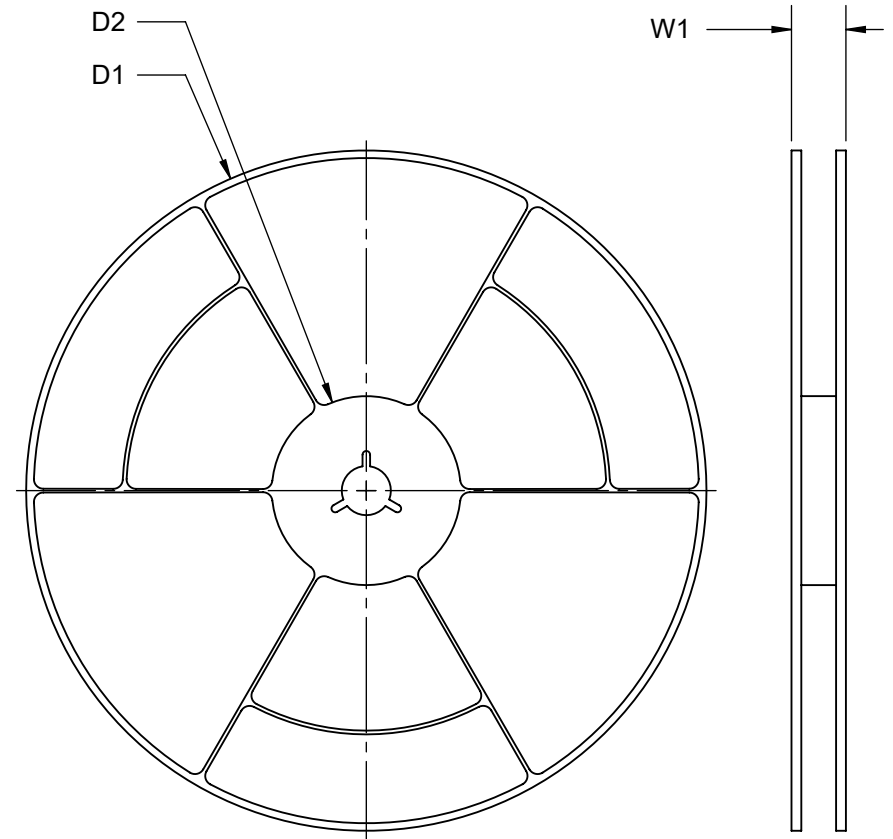
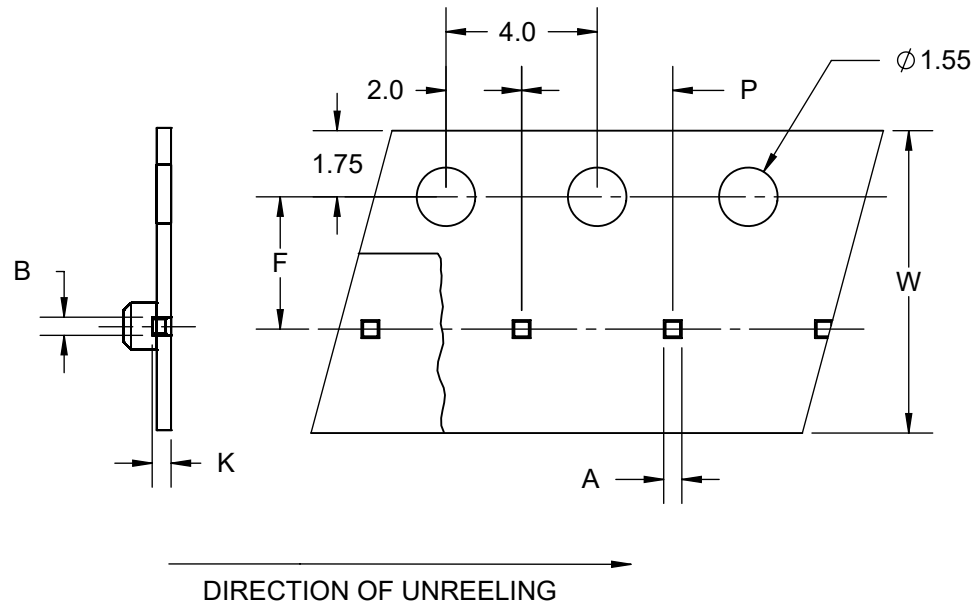

ALL DIMENSIONS IN mm.

# PRELIMINARY

TAPE AND REEL DIMENSIONS		E7A 7-INCH SSL01501514
	SYMBOL	
TAPE WIDTH	W	8
PITCH OF COMPONENTS	P	4
POCKET WIDTH	A	0.48
POCKET LENGTH	B	0.48
POCKET DEPTH	K	.50
CARRIER THICKNESS	C	1.2
REEL DIAMETER	D1	178
HUB DIAMETER	D2	50~60
PUNCH HOLE POSITION	F	3.5
MAX REEL WIDTH	W1	11.4

**TopLine**<sup>®</sup>

TITLE  
SSL01501514-R-G  
SOLDERABLE SPACER

SCALE 5:1	SIZE A	DRAWING NO. 151514	REV A
--------------	-----------	-----------------------	----------

DO NOT SCALE DRAWING

SHEET 4 OF 5

# LEAD FREE REFLOW PROFILE OF SMD PACKAGE

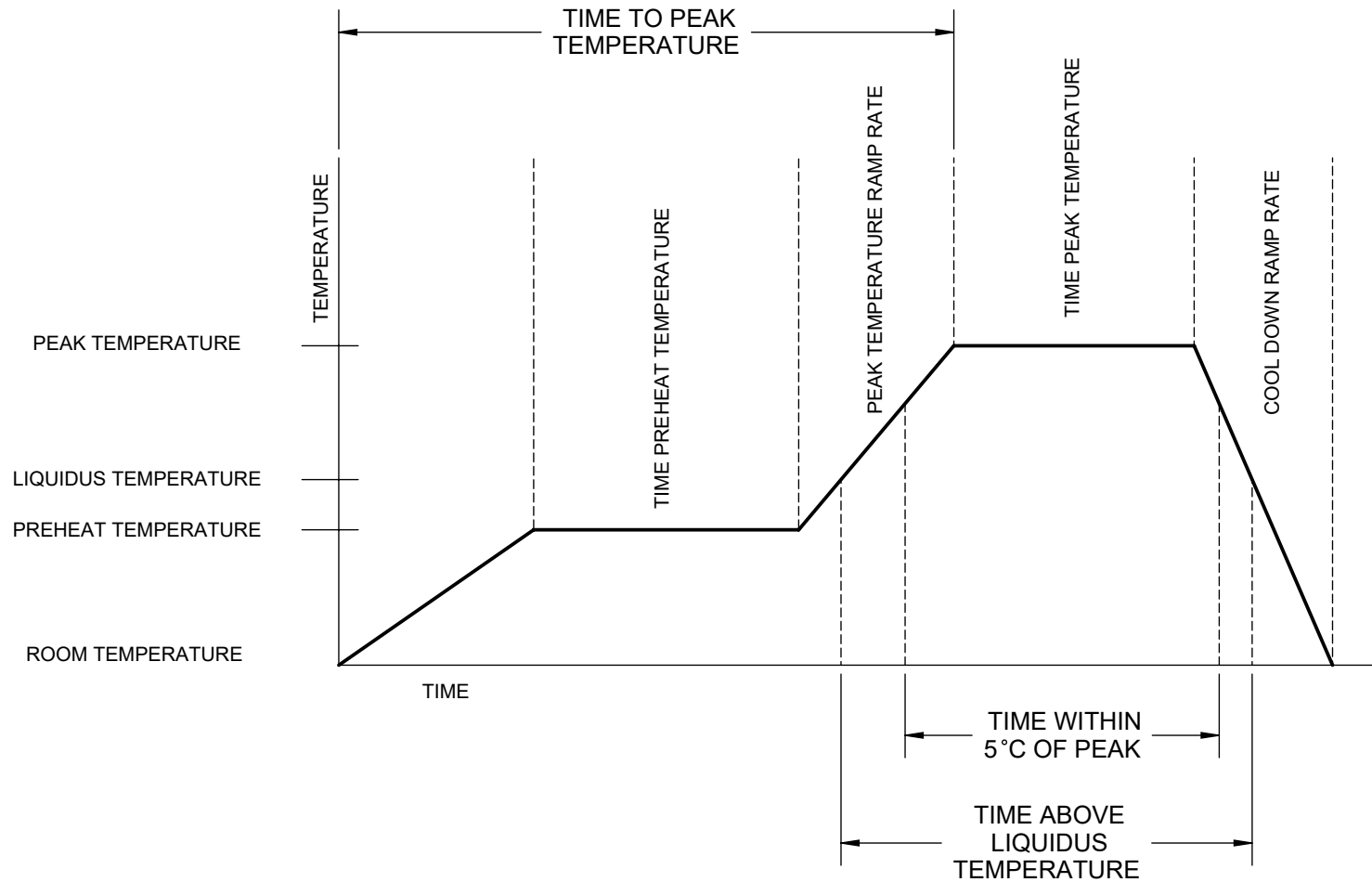

DESCRIPTION	REQUIREMENT
AVERAGE PREHEAT RAMP RATE	3°C /SECOND MAXIMUM
PREHEAT TEMPERATURE	150°C MINIMUM, 200°C MAXIMUM
PREHEAT TIME	60 TO 120 SECONDS
RAMP TO PEAK	3°C /SECOND MAXIMUM
TIME OVER LIQUIDUS (217°C)	60 TO 260 SECONDS
PEAK TEMPERATURE	260°C +0/-5°C
TIME WITHIN 5°C OF PEAK	10 TO 30 SECONDS
RAMP - COOL DOWN	6°C /SECONDS MAXIMUM
TIME 25°C TO PEAK	8 MINUTES MAXIMUM

<b>TopLine®</b>			
TITLE		SSL01501514-R-G SOLDERABLE SPACER	
SCALE	SIZE	DRAWING NO.	REV
NONE	A	151514	A
DO NOT SCALE DRAWING			SHEET 5 OF 5