

SECTION A-A

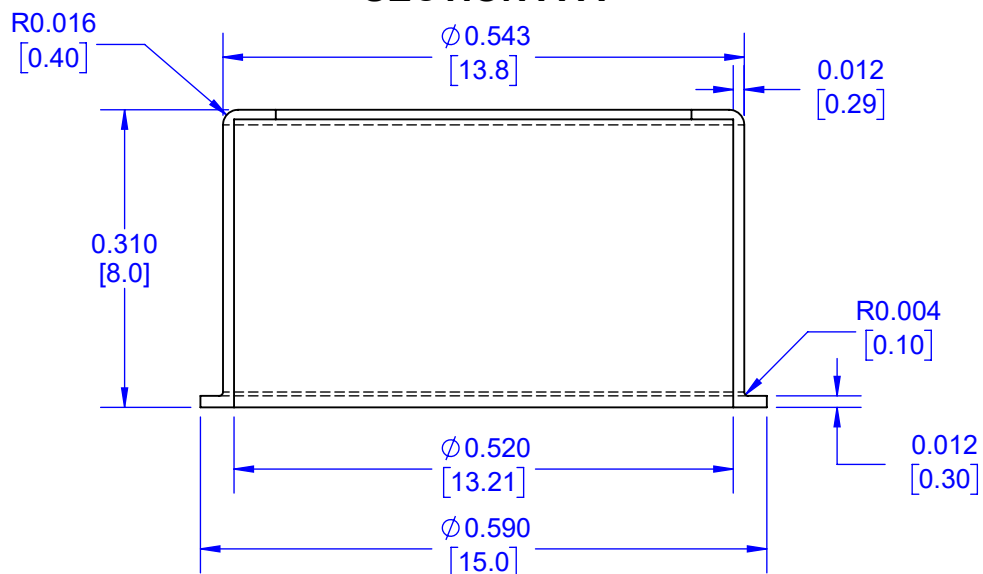

TOP VIEW

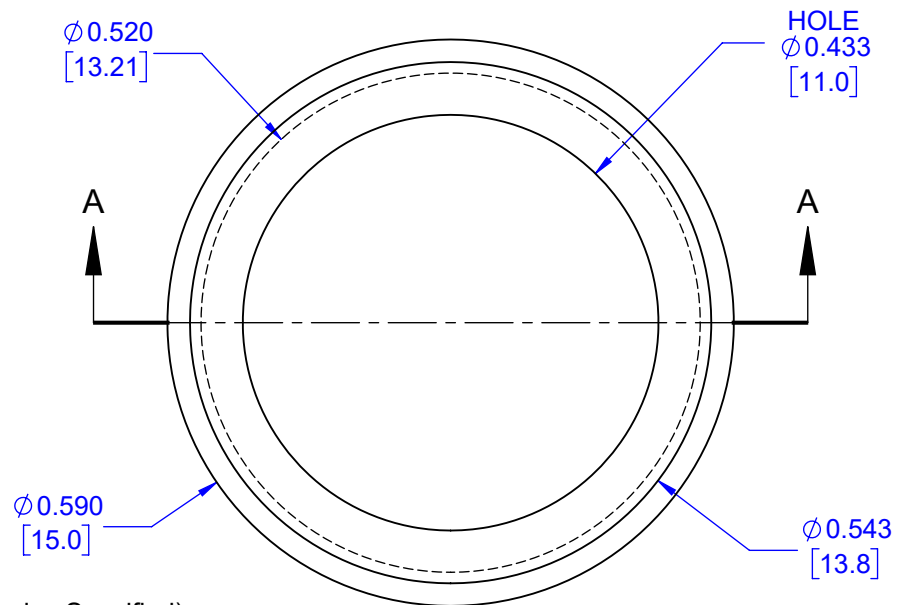

TO-8 CAN (LID / CAP)

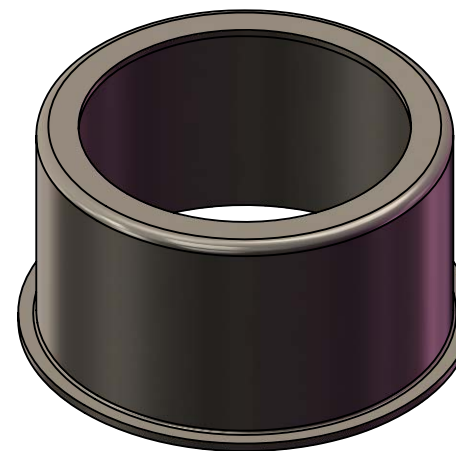

MODEL

Notes: (Unless Otherwise Specified)

- 1) DIMENSIONS: INCH [mm].
- 2) CAN - CAP LID FOR TO-8 HEADER.
- 3) BASIC MATERIAL SPCC.
- 4) PLATING: NICKEL 120~250 micro-inch (3~6um).
- 5) WITHOUT WELD PROJECTION.

APPROVALS	DATE	TopLine®			
DRAWN T. Au	07/20/25				
ENG M. Hart	07/20/25	TITLE TO-8 CAN WITH 11MM HOLE 0.310" (8.0mm) HIGH			
MFG		SCALE	SIZE	DRAWING NO.	REV
QA		5:1	A	171131	A
CUST		DO NOT SCALE DRAWING			SHEET 1 OF 1
REVISED					