

ITEM	NAME	MATERIAL / COMPOSED PARTS	QTY
1	LID	Fe-Ni-Co ALLOY	1

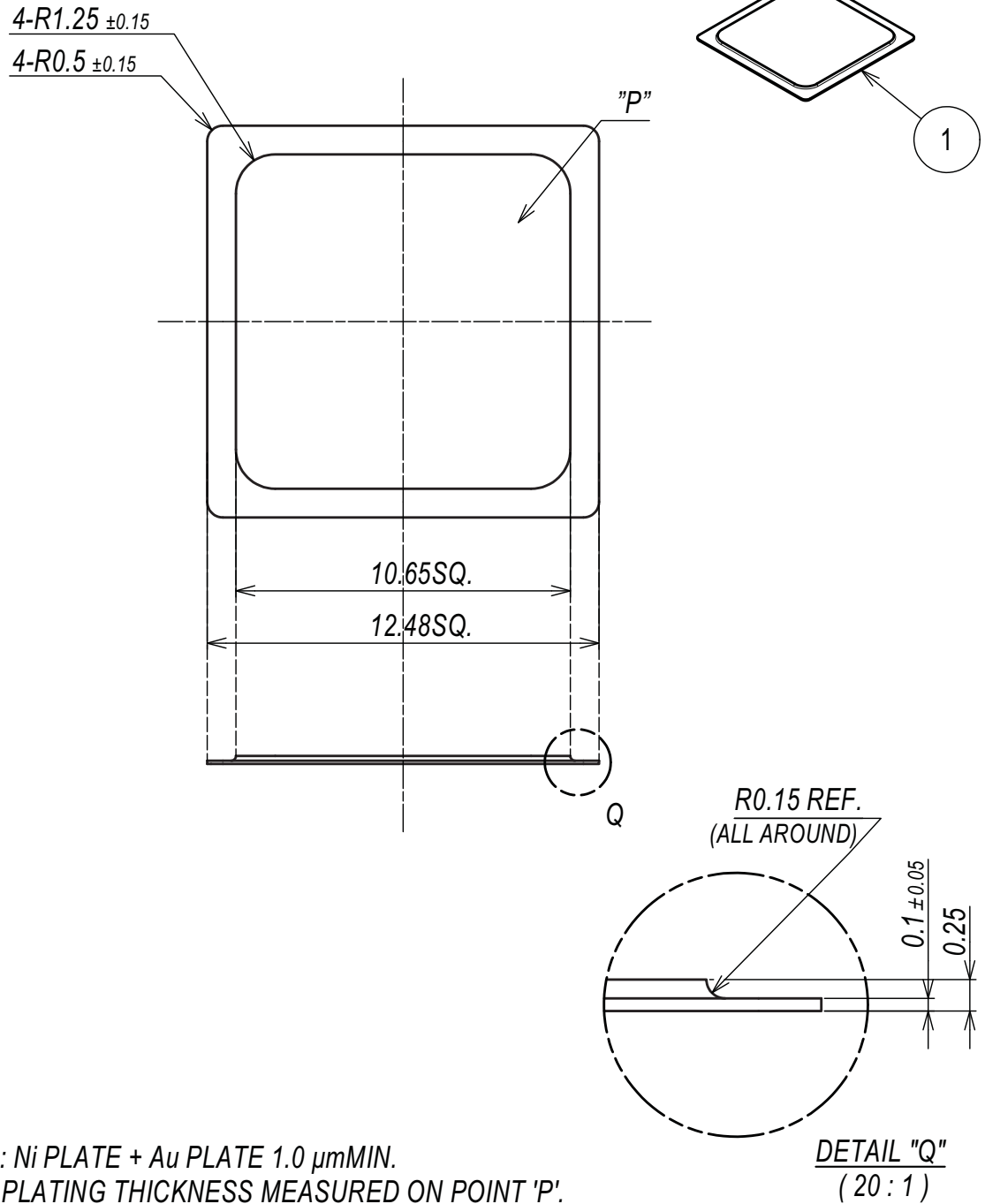

**NOTES**

1. FINISH: Ni PLATE + Au PLATE 1.0 μmMIN.  
PLATING THICKNESS MEASURED ON POINT 'P'.
2. NO BLISTERS ON Au AFTER 3MINUTES (IN AIR OVEN) AT 400°C AS SEEN UNDER 10X MAGNIFICATION.
3. PLATING RACK POINT MARKS TO BE PERMITTED ON ALL AROUND EDGES. (NOT APPLY NOTE.1,2)

NAME <b>LID FOR 6140</b>		UNITS mm
TOLERANCES UNLESS OTHERWISE SPECIFIED <b>±0.12</b>	DWG No. <b>PGMR-A9388</b>	1 1