

TOP VIEW

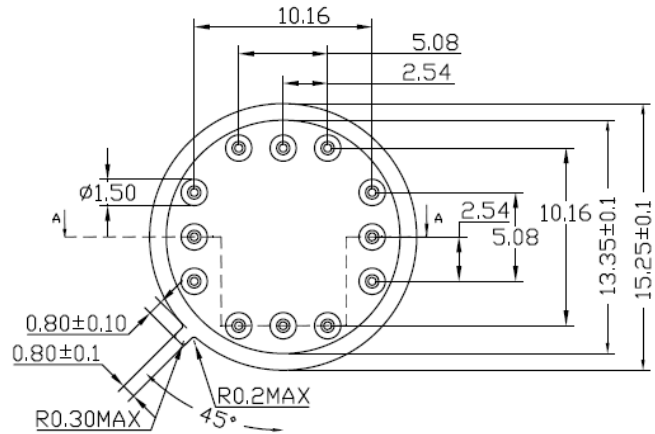

NOTES:

1. MATERIAL: SEE TABLE 1.
2. FINISH: GOLD PLATED 50 MICROINCHES OVER
100-150 MICROINCHES NICKEL PLATED
3. HERMETICITY: 1×10^{-8} He/sec
4. PARTS TO BE FREE FROM OIL, GREASE AND OTHER CONTAMINATES.
5. CERTIFICATE OF COMPLIANCE SHALL ACCOMPANY EACH SHIPMENT.
6. SHIPPING CONTAINER SHALL BE MARKED WITH P/N, P.O NO AND VENDOR LOT NO.

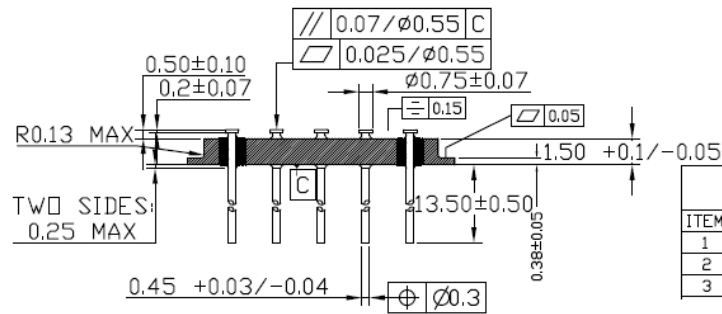

SECTION A-A
SIDE VIEW

NOTES:
1) DIMENSIONS IN MM

BILL OF MATERIAL			
ITEM	P/N	DESCRIPTION	QTY
1	050-01788-01	BASE 4J29 NI-FE-CO, KOVAR	1
2	050-01788-02	PIN 4J29 NI-FE-CO, KOVAR	12
3	050-01788-03	GLASS PREFORM	12

APPROVALS	DATE	TopLine®			
DRAWN T. Au	09/23/12				
ENG M. Hart	09/23/12	TITLE TO-8 HEADER12L			
MFG		SCALE 50:1	SIZE A	DRAWING NO. 150822	REV A
QA					
CUST		DO NOT SCALE DRAWING			
REVISED					