

### TOP VIEW

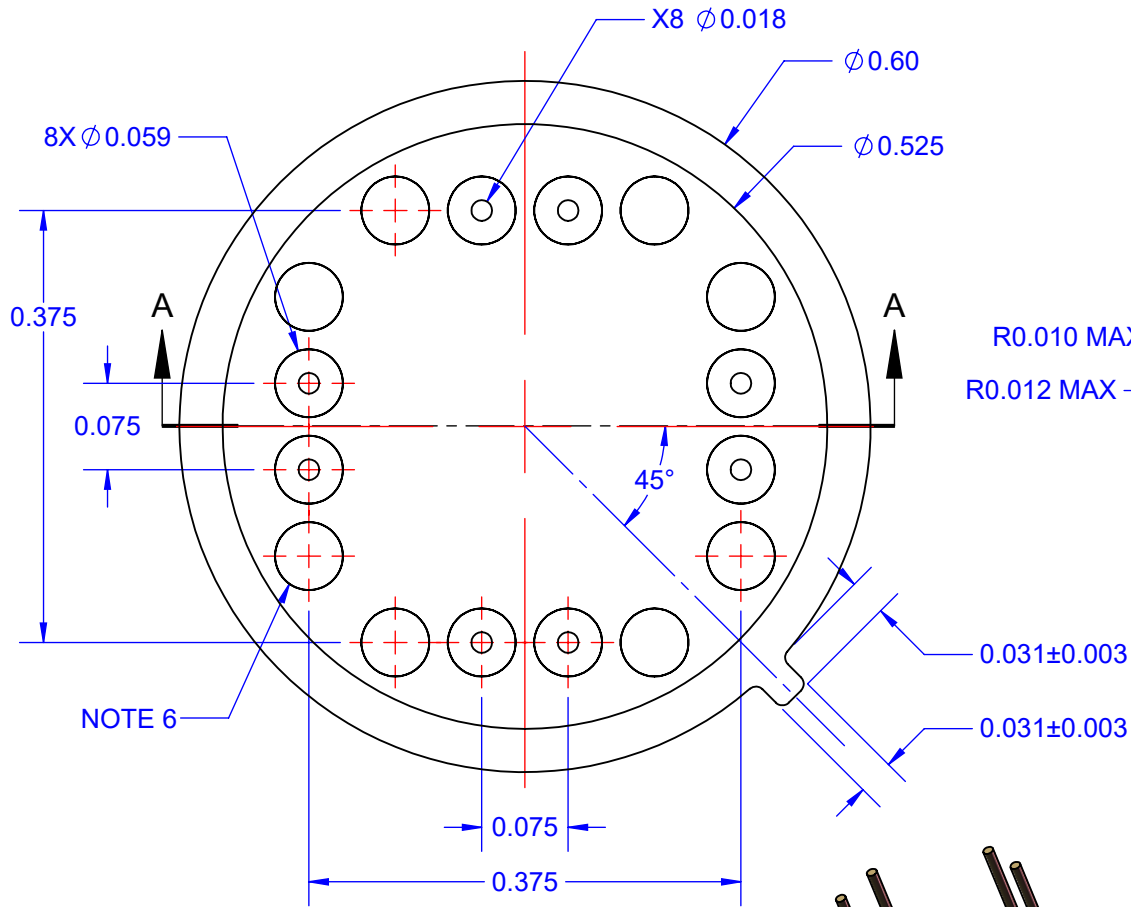

### SECTION VIEW A-A

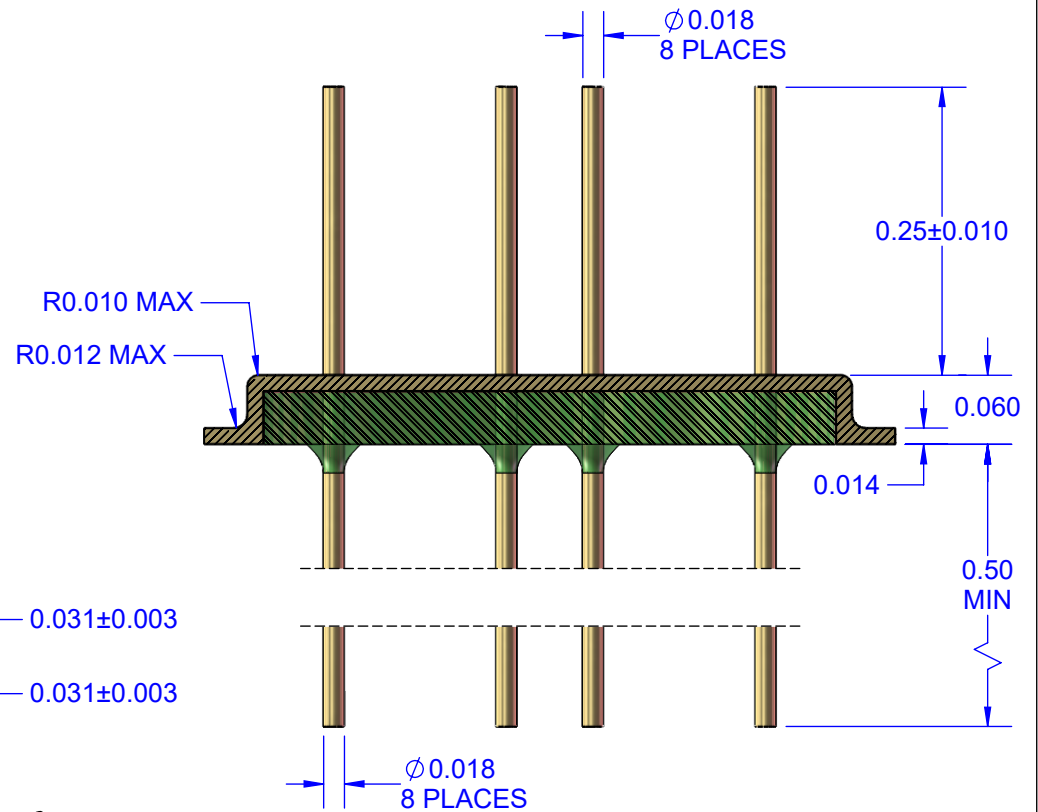

SECTION A-A  
SCALE 6 : 1

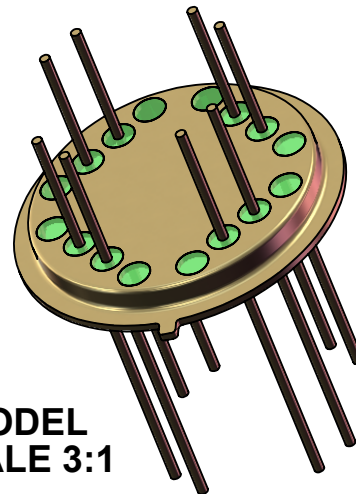

**NOTES:**

1. DIMENSIONS: INCH (Unless Otherwise Specified).
2. BODY KOVAR ASTM F45 ALLOY 42.
3. LEADS KOVAR ASTM F15.
4. GLASS 7052 OR EQUIVALENT.
5. PLATING: Ni 100~300 Micro-inch  
Au 50 Micro-inch MIN
6. UNUSED PINS ARE PLUGGED WITH GLASS-FILLED HOLES (8X).

APPROVALS	DATE	<b>TopLine®</b>			
DRAWN T.Au	7/5/2025				
ENG M. Hart	7/5/2025	TITLE TO-8 HEADER 8L NAIL HEAD ISOLATED			
MFG		SCALE	SIZE	DRAWING NO.	REV
QA		6:1	A	108080	A
CUST		DO NOT SCALE DRAWING			SHEET 1 OF 1
REVISED					