

TOP VIEW

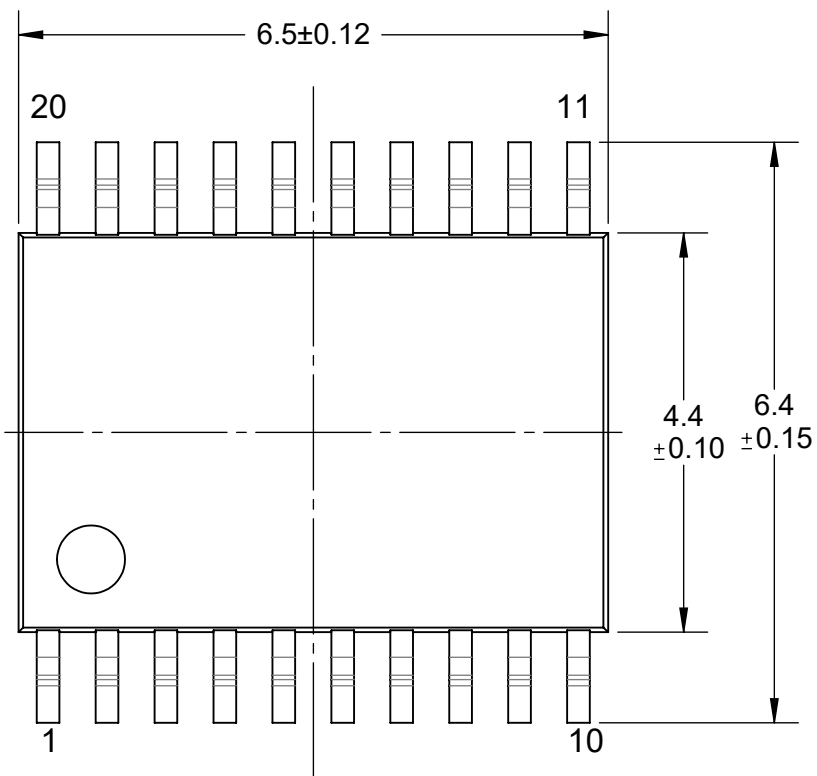

DETAIL A

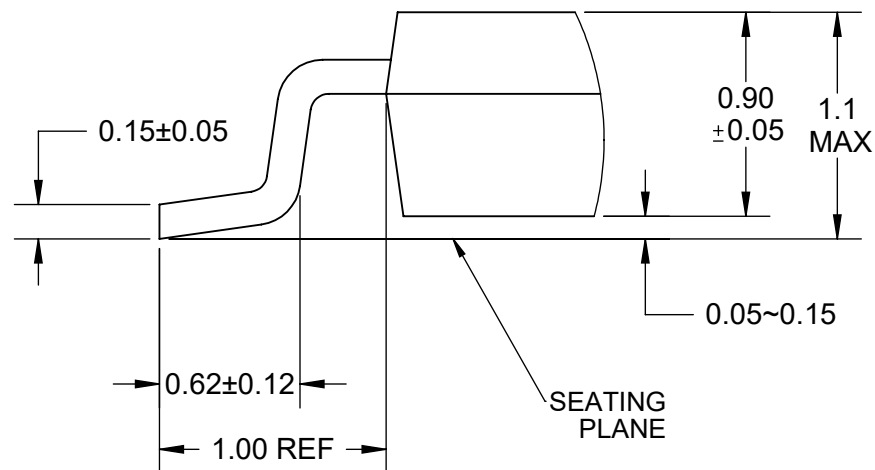

SIDE VIEW

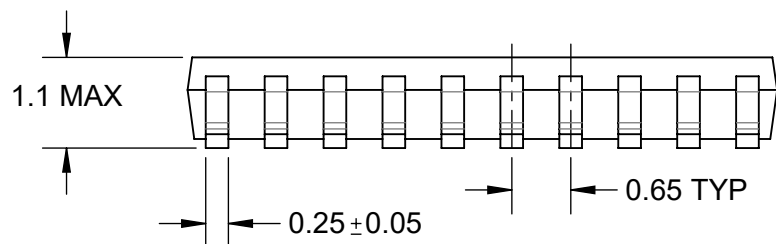

END VIEW

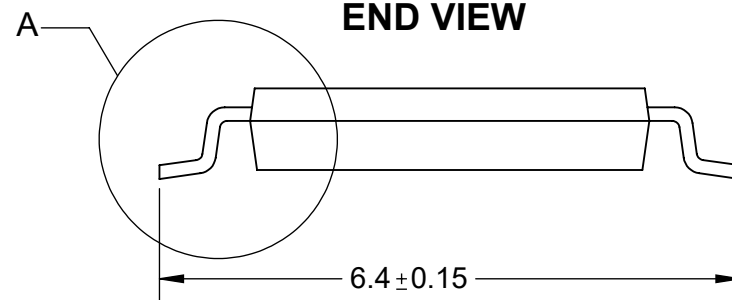

Notes: (Unless Otherwise Specified)

1. DIMENSIONS mm.
2. SEE DAISY CHAIN JUMPER DIAGRAMS (PAGE 2).
3. SEE PART NUMBER CONFIGURATION (PAGE 3).
4. RECOMMENDED PC BOARD LAYOUT PATTERN (PAGE 5).

APPROVALS	DATE	TopLine®			
DRAWN T.Au	9/12/2020				
ENG M. Hart	9/12/2020	TITLE TSSOP20 OUTLINE PACKAGE			
MFG		SCALE	SIZE	DRAWING NO.	REV
QA		10:1	A	122006	A
CUST		DO NOT SCALE DRAWING			SHEET 1 OF 6
REVISED					

INTERNAL WIRING CIRCUIT (JUMPER) DAISY CHAIN PART NUMBER SUFFIX TOP VIEW

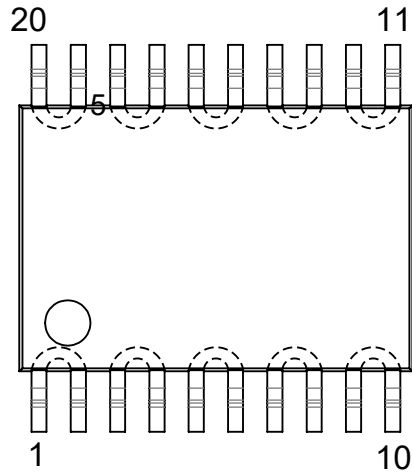

DE
DAISY CHAIN
EVEN

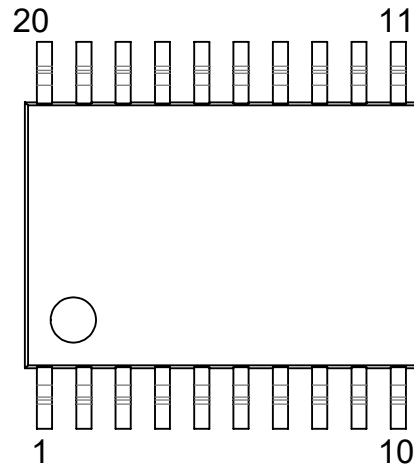

ISO
ISOLATED CIRCUIT
NO INTERNAL
CONNECTIONS

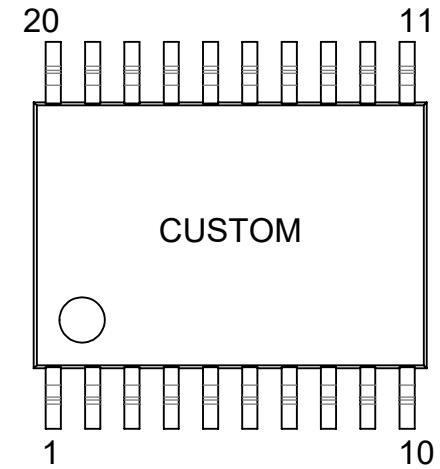

DC##
CUSTOM JUMPER
CONTACT TOPLINE

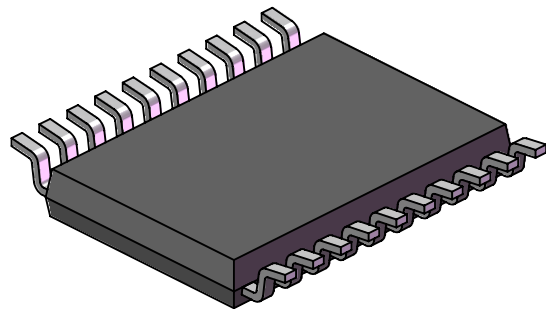

BOTTOM

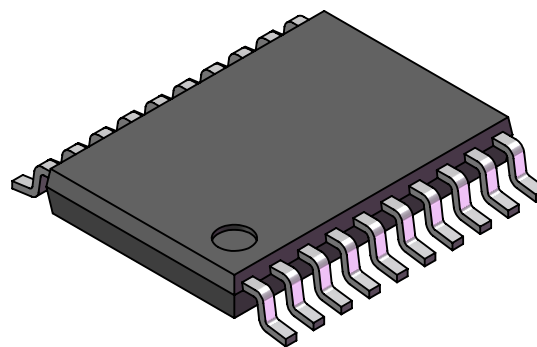

TOP

MODEL

TopLine®			
TITLE TSSOP20 OUTLINE PACKAGE			
SCALE 10:1	SIZE A	DRAWING NO. 122006	REV A
DO NOT SCALE DRAWING			SHEET 2 OF 6

PART NUMBERING SYSTEM

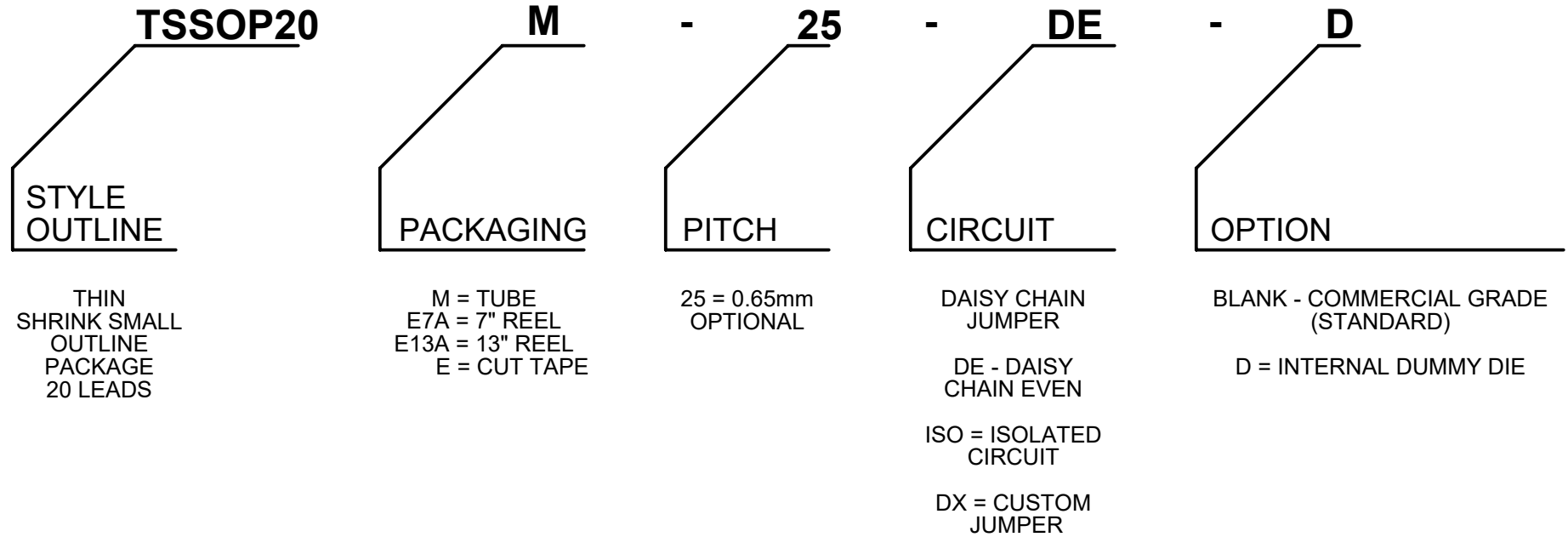

PART NUMBER	SHORTED PINS	NOTES	RoHS Pb-FREE	MSL LEVEL
TSSOP20E13A25-T	N/A	DUMMY	YES	1
TSSOP20E13A25-T-ISO	NONE	ISOLATED	YES	1
TSSOP20E13A25-T-DE-D	1~2, 3~4 5~6, 7~8, 9~10, 11~12, 13~14, 15~16, 17~18, 19~20	DAISY CHAIN	YES	1
TSSOP20M25-T-DE-D	1~2, 3~4 5~6, 7~8, 9~10, 11~12, 13~14, 15~16, 17~18, 19~20	DAISY CHAIN	YES	1

TopLine®			
TITLE TSSOP20 OUTLINE PACKAGE			
SCALE NONE	SIZE A	DRAWING NO. 122006	REV A
DO NOT SCALE DRAWING			SHEET 3 OF 6

TAPE SPECIFICATION TSSOP20 SURFACE MOUNT DEVICE

TAPE DIMENSIONS

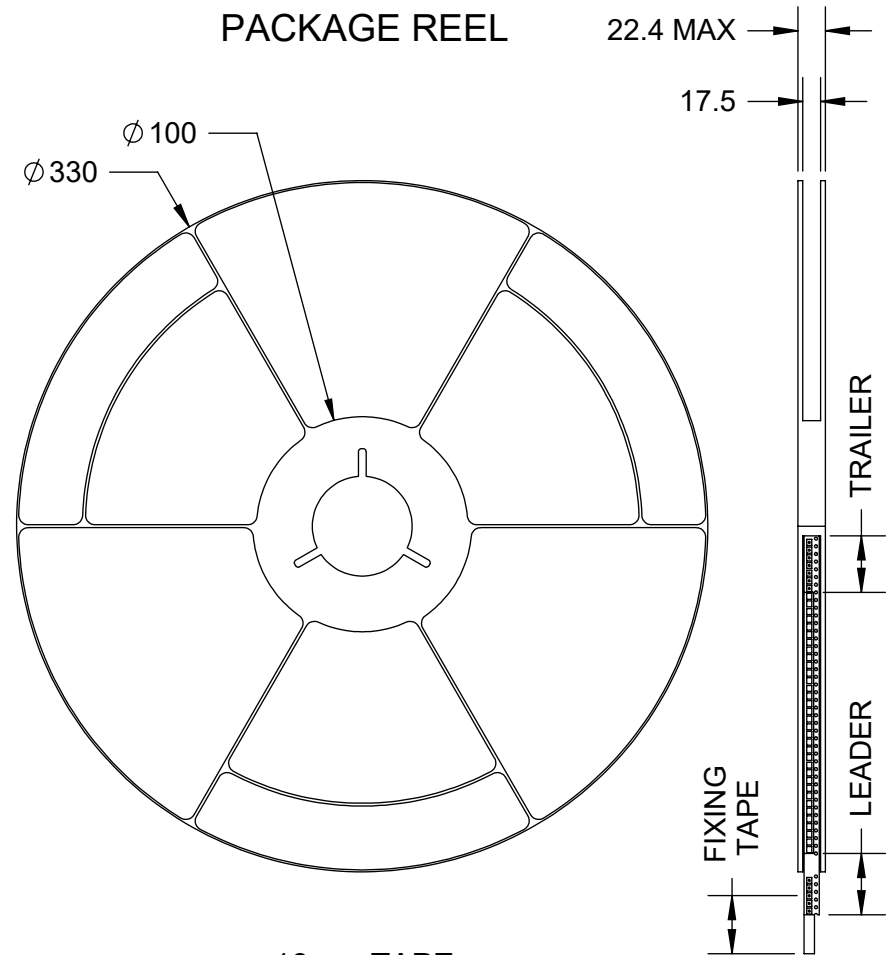
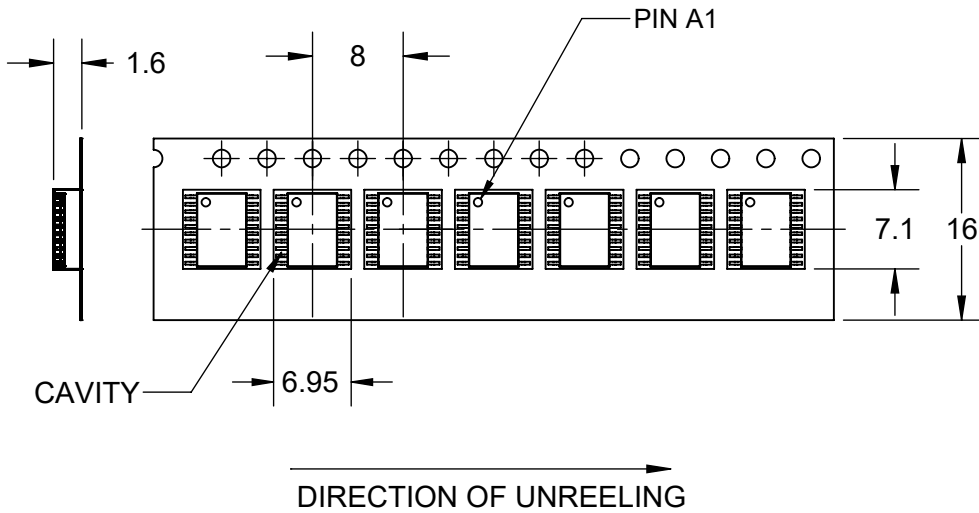

16mm TAPE
1000~2500 PCS

ALL DIMENSIONS IN mm.

TopLine®			
TITLE TSSOP20 OUTLINE PACKAGE			
SCALE 3:2	SIZE A	DRAWING NO. 122006	REV A
DO NOT SCALE DRAWING			SHEET 4 OF 6

PCB BOARD LAND PATTERN

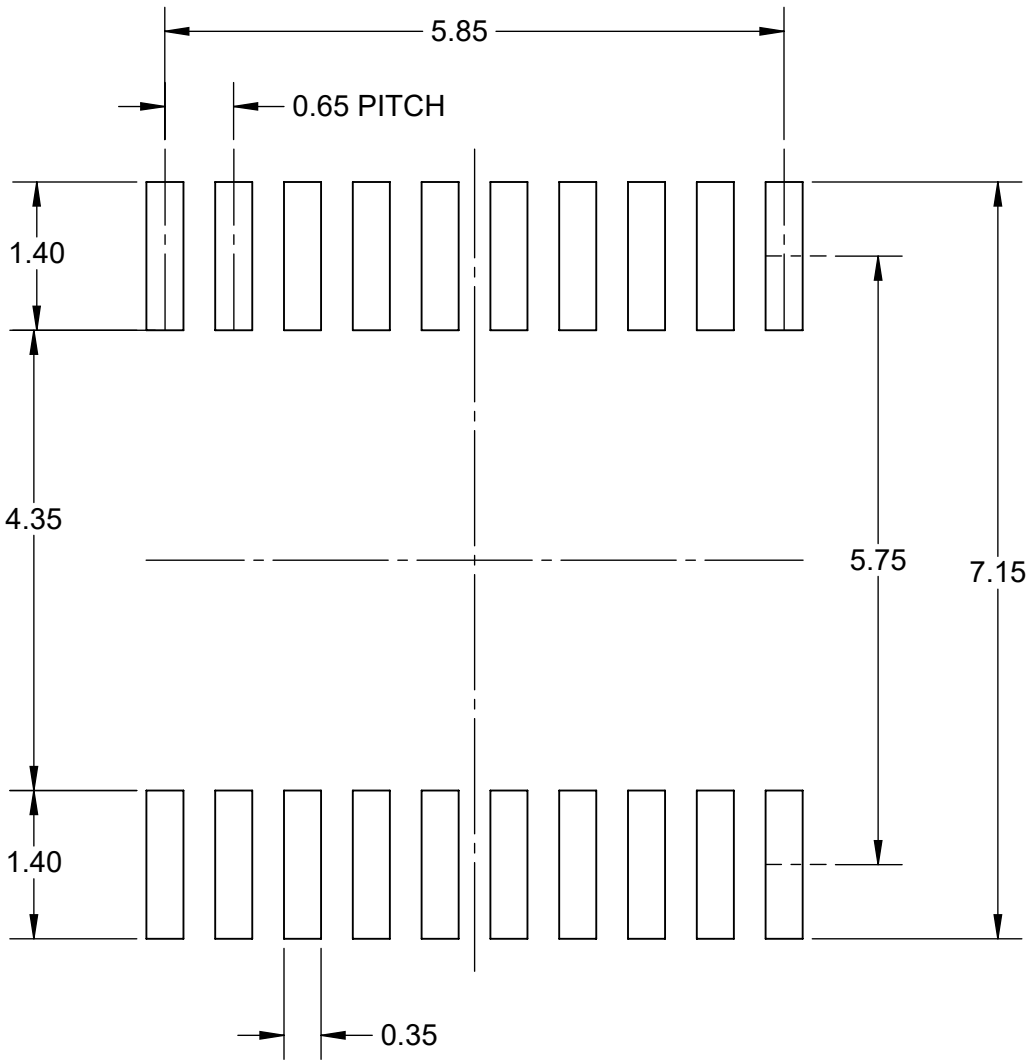

Notes: (Unless Otherwise Specified)

1. DIMENSIONS ARE IN mm.
2. PCB BOARD DIMENSIONS ARE PRESENTED ONLY AS A GUIDELINE.
3. DESIGNERS SHOULD USE THEIR OWN EXPERIENCE WHEN DESIGNING PCB.

TopLine®			
TITLE		TSSOP20 OUTLINE PACKAGE	
SCALE	SIZE	DRAWING NO.	REV
12:1	A	122006	A
DO NOT SCALE DRAWING			SHEET 5 OF 6

LEAD FREE REFLOW PROFILE OF SMD PACKAGE

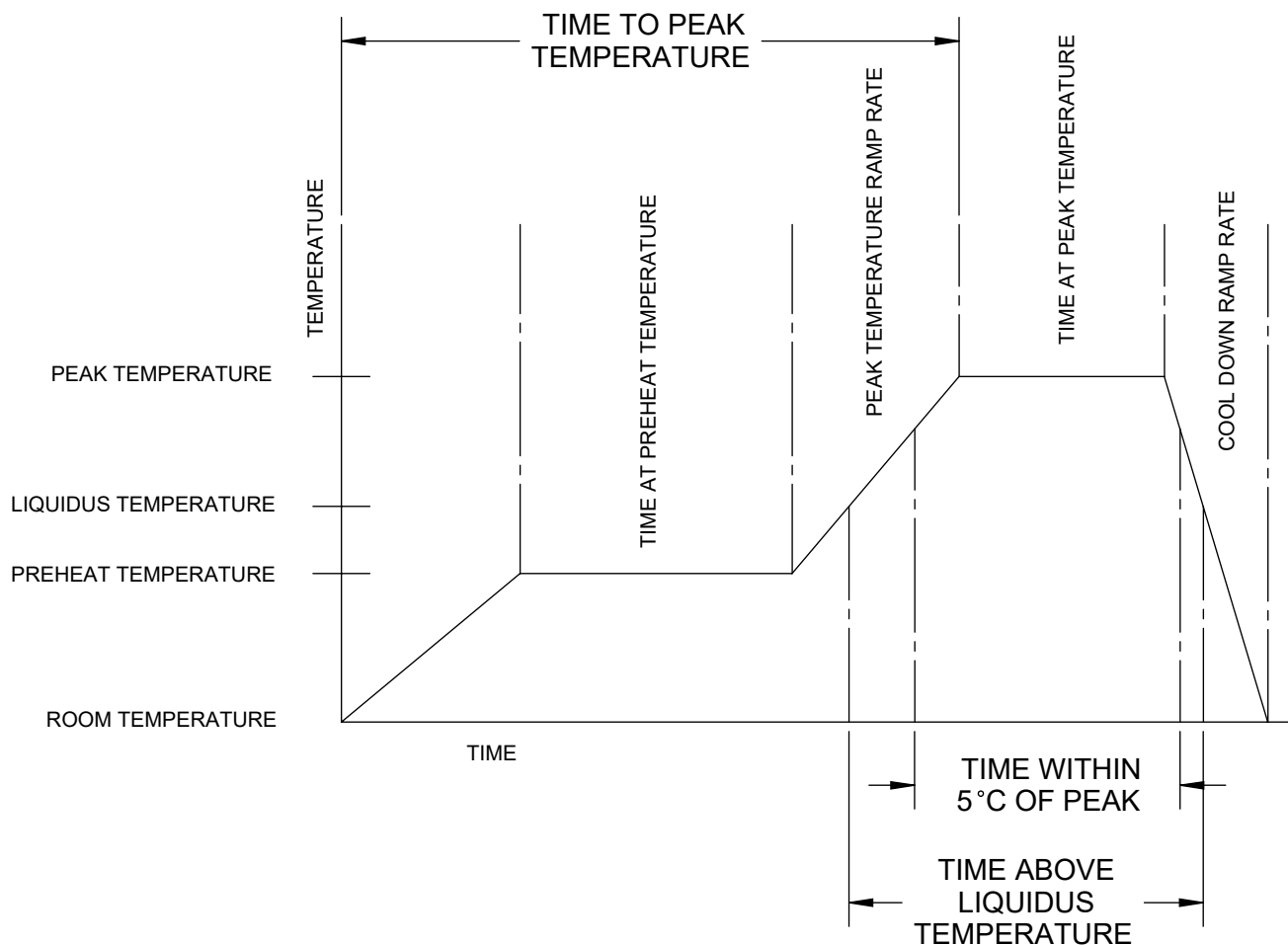

DESCRIPTION	REQUIREMENT
AVERAGE PREHEAT RAMP RATE	3°C /SECOND MAXIMUM
PREHEAT TEMPERATURE	150°C MINIMUM, 200°C MAXIMUM
PREHEAT TIME	60 TO 80 SECONDS
RAMP TO PEAK	3°C /SECOND MAXIMUM
TIME OVER LIQUIDUS (217°C)	60 TO 150 SECONDS
PEAK TEMPERATURE	260°C +0/-5°C
TIME WITHING 5°C OF PEAK	20 TO 40 SECONDS
RAMP - COOL DOWN	6°C /SECONDS MAXIMUM
TIME 25°C TO PEAK	6 MINUTES MAXIMUM

TopLine®

TITLE TSSOP20
OUTLINE PACKAGE

SCALE NONE	SIZE A	DRAWING NO. 122006	REV A
---------------	-----------	-----------------------	----------

DO NOT SCALE DRAWING

SHEET 6 OF 6