

SIDE VIEW

.095
.162
.250
.025

SECTION A-A
TOP GRAPHITE

P SEE SHEET 3
.031 X 45°
CHAMFER

ALIGNMENT PIN DETAIL
SCALE = 2:1

R.050
.500
.030 X 15°
CHAMFER
 $\phi .2502^{+.0000}_{-.0002}$

4X $\phi .221$ THRU

2.000

8X $\phi .063$ THRU

8X R.047

.030 X 15°
CHAMFER

TOPLINE

$\phi .026$ THRU ALL
 $\phi .043$ X 90°, NEAR SIDE

4X R.500

3.378
3.878
2.150
2.343^{+.004}_{-.000}
3.0

.500
TYP

.009
45°
.063
.088

DETAIL B
SCALE 10:1

$\phi .156 \nabla .039$
FLAT BOTTOM

.050
PITCH
TYP

.050 TYP
2.150
2.343^{+.004}_{-.000}
2.600 SQ
3.012
3.390
3.878

APPROVALS		DATE				
DRAWN	J. Hines	1/4/2018	TITLE C7-GRAPHITE-1752-RU GRAPHITE TOOL			
ENG	M. Hart	1/4/2018				
MFG			SCALE 1:1	SIZE A	DRAWING NO. 724482	REV A
QA						
CUST			DO NOT SCALE DRAWING		SHEET 1 OF 14	
REVISED						

BOTTOM VIEW
TOP GRAPHITE

4X ϕ .209 THRU ALL
 \checkmark ϕ .221 X 90°, NEAR SIDE

ϕ .188 THRU ALL
 ϕ .2503^{+.0002}_{-.0000} ∇ .138

4X ϕ .063 THRU

4X R.047

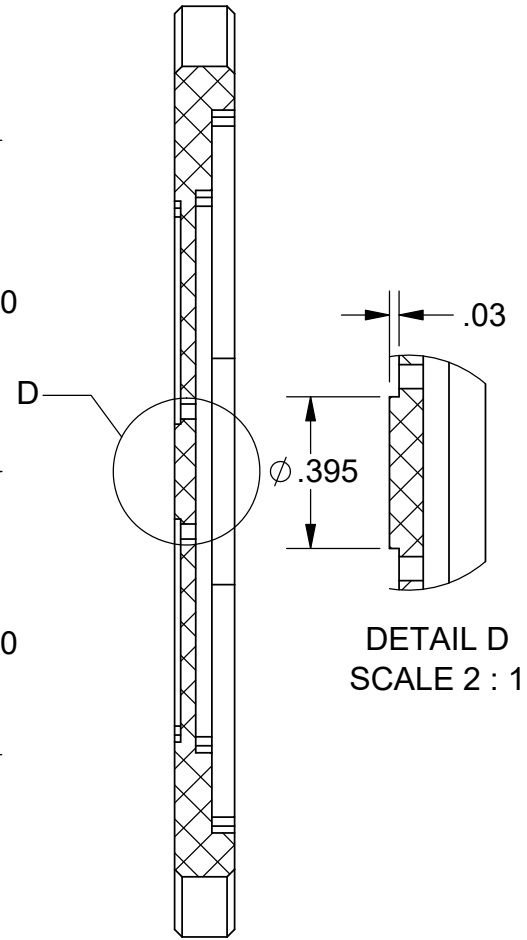
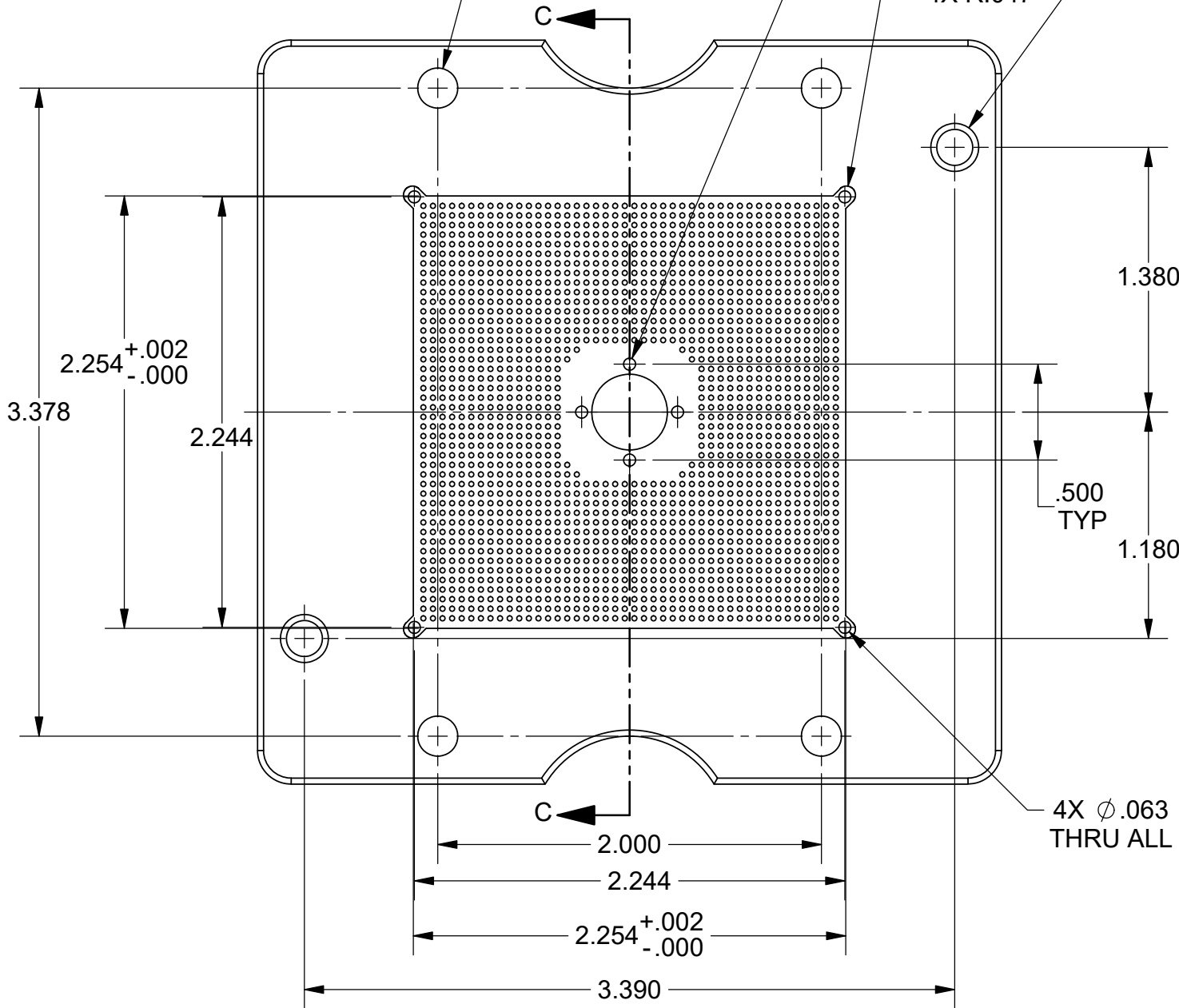

DETAIL D
SCALE 2 : 1

SECTION C-C

TopLine [®]			
TITLE C7-GRAPHITE-1752-RU GRAPHITE TOOL			
SCALE 1.25:1	SIZE A	DRAWING NO. 724482	REV A
DO NOT SCALE DRAWING			SHEET 2 OF 14

ALIGNMENT PIN
DWG 702562

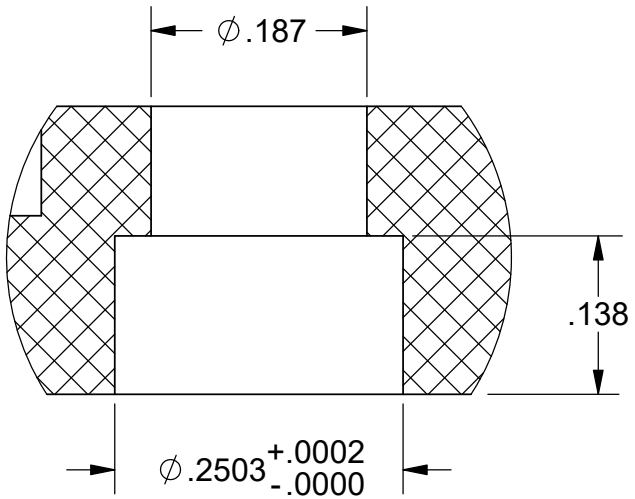

DETAIL P
SEE SHEET 1

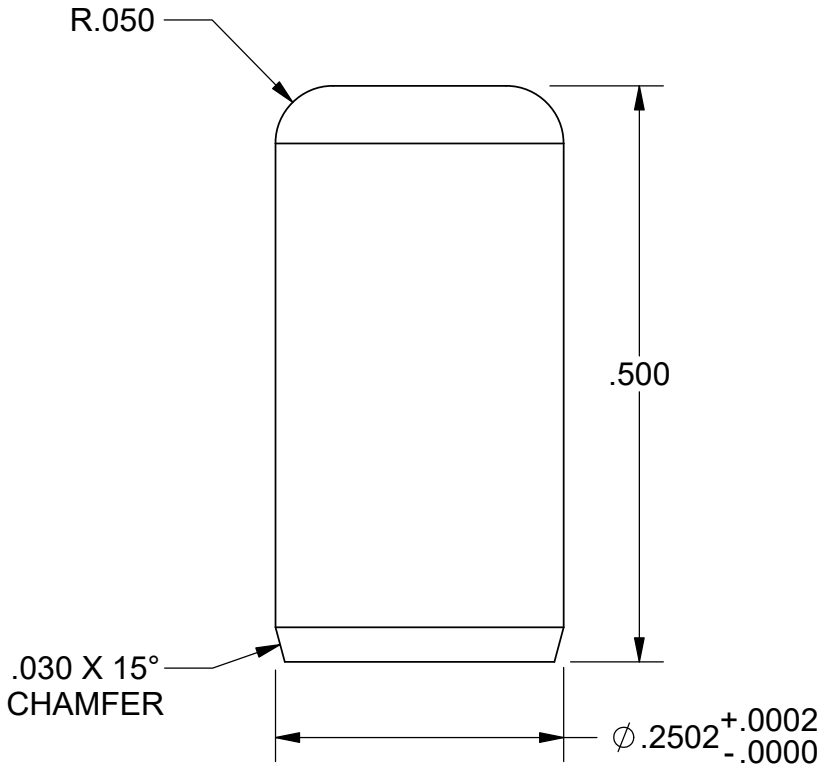

NOTES: (UNLESS OTHERWISE SPECIFIED).
1) DIMENSIONS: MM [INCH].

TopLine [®]			
TITLE C7-GRAPHITE-1752-RU GRAPHITE TOOL			
SCALE 6:1	SIZE A	DRAWING NO. 724482	REV A
DO NOT SCALE DRAWING		SHEET 3 OF 14	

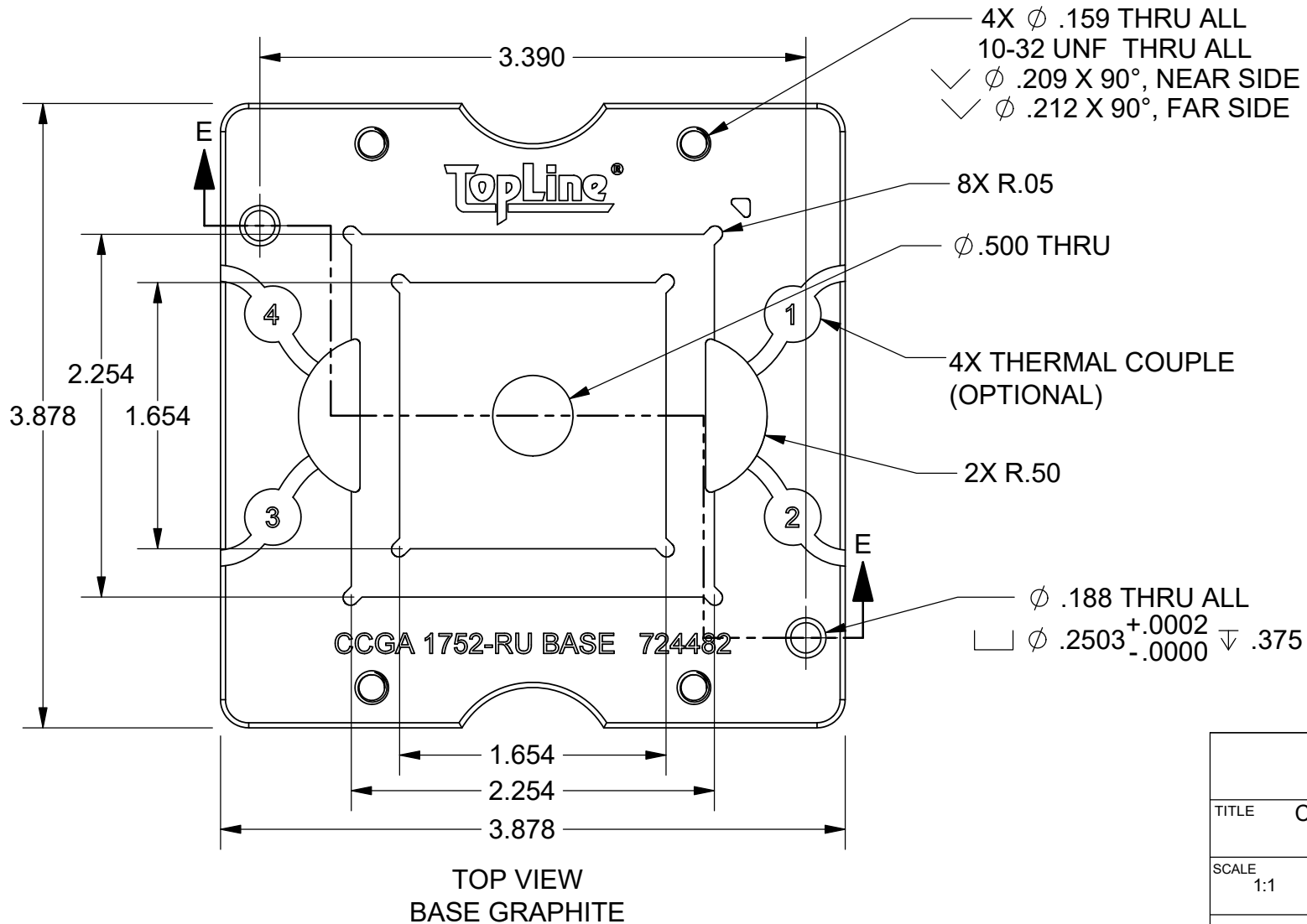
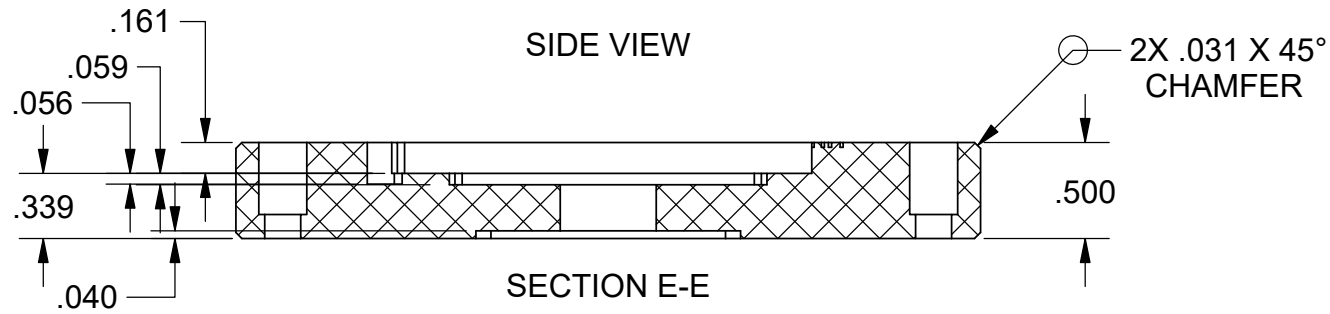

TopLine®			
TITLE C7-GRAPHITE-1752-RU GRAPHITE TOOL			
SCALE 1:1	SIZE A	DRAWING NO. 724482	REV A
DO NOT SCALE DRAWING		SHEET 4 OF 14	

BOTTOM VIEW
BASE GRAPHITE

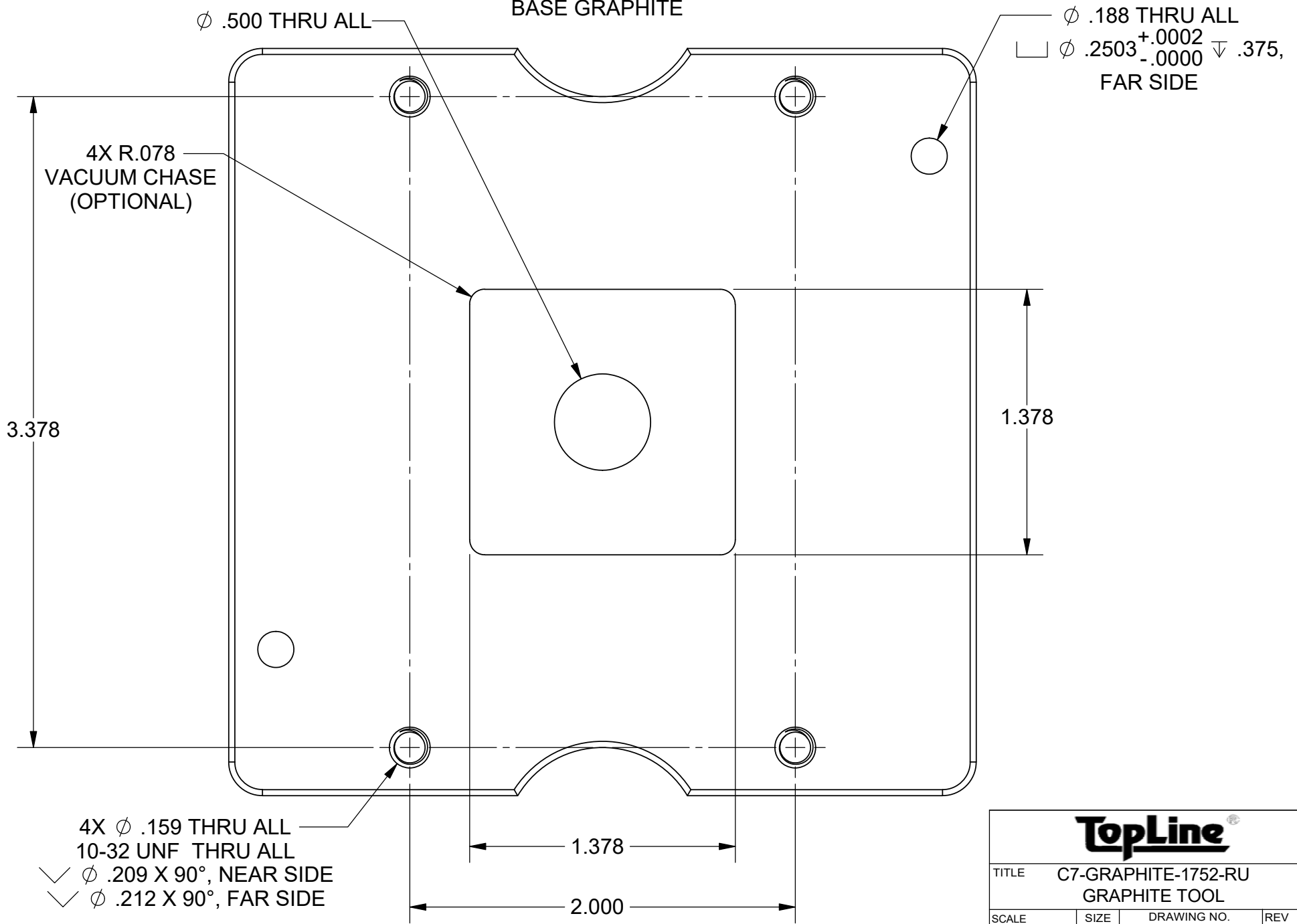

TopLine[®]

TITLE C7-GRAPHITE-1752-RU GRAPHITE TOOL			
SCALE 1.5:1	SIZE A	DRAWING NO. 724482	REV A
DO NOT SCALE DRAWING		SHEET 5 OF 14	

GRAPHITE CAP
700160

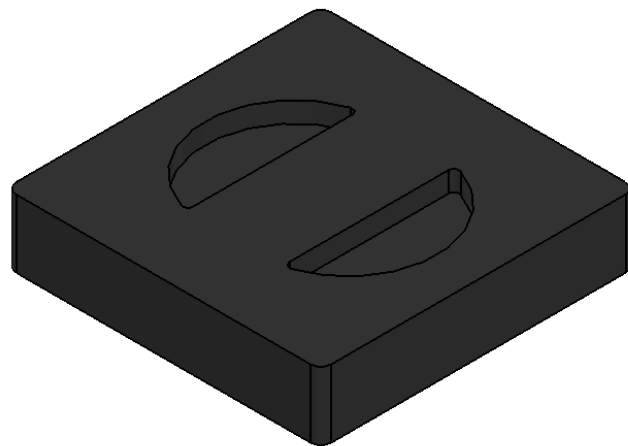
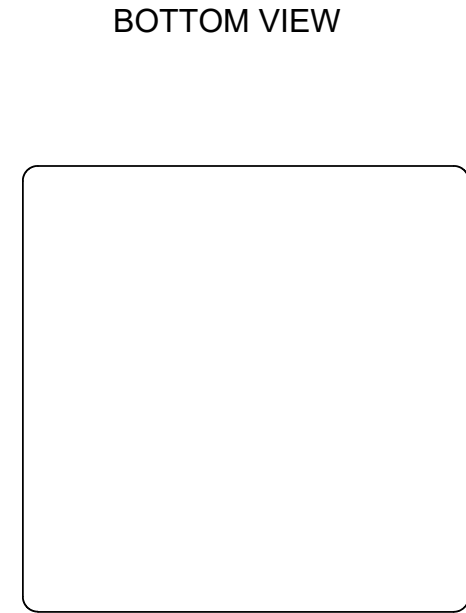
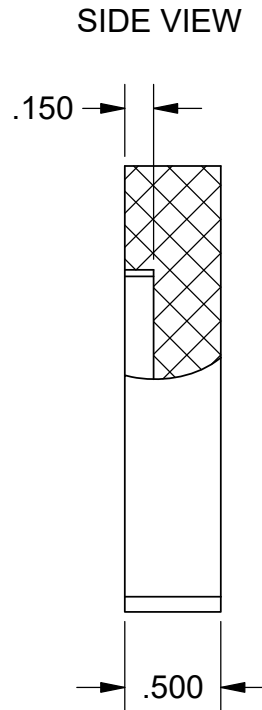
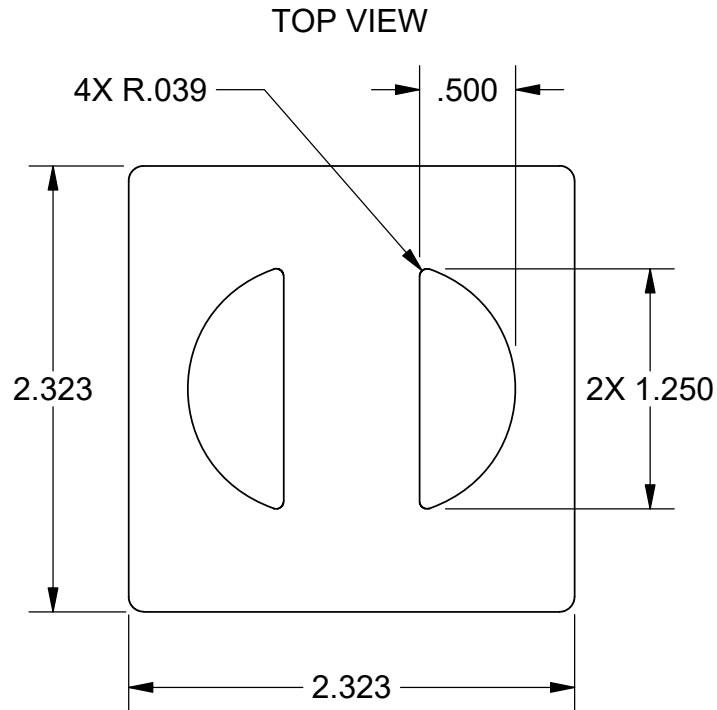

MODEL
DWG 700160

NOTES: (UNLESS OTHERWISE SPECIFIED).

- 1) DIMENSIONS: MM.
- 2) MATERIAL: GRAPHITE.
- 3) OMNI-DIRECTIONAL.
- 4) APPLICATION: APPLIES PRESSURE TO COLUMNS.

TopLine [®]			
TITLE C7-GRAPHITE-1752-RU GRAPHITE TOOL			
SCALE 1:1	SIZE A	DRAWING NO. 724482	REV A
DO NOT SCALE DRAWING		SHEET 6 OF 14	

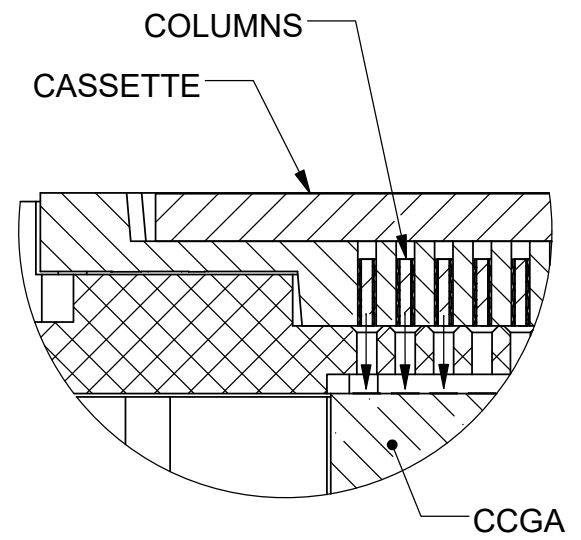
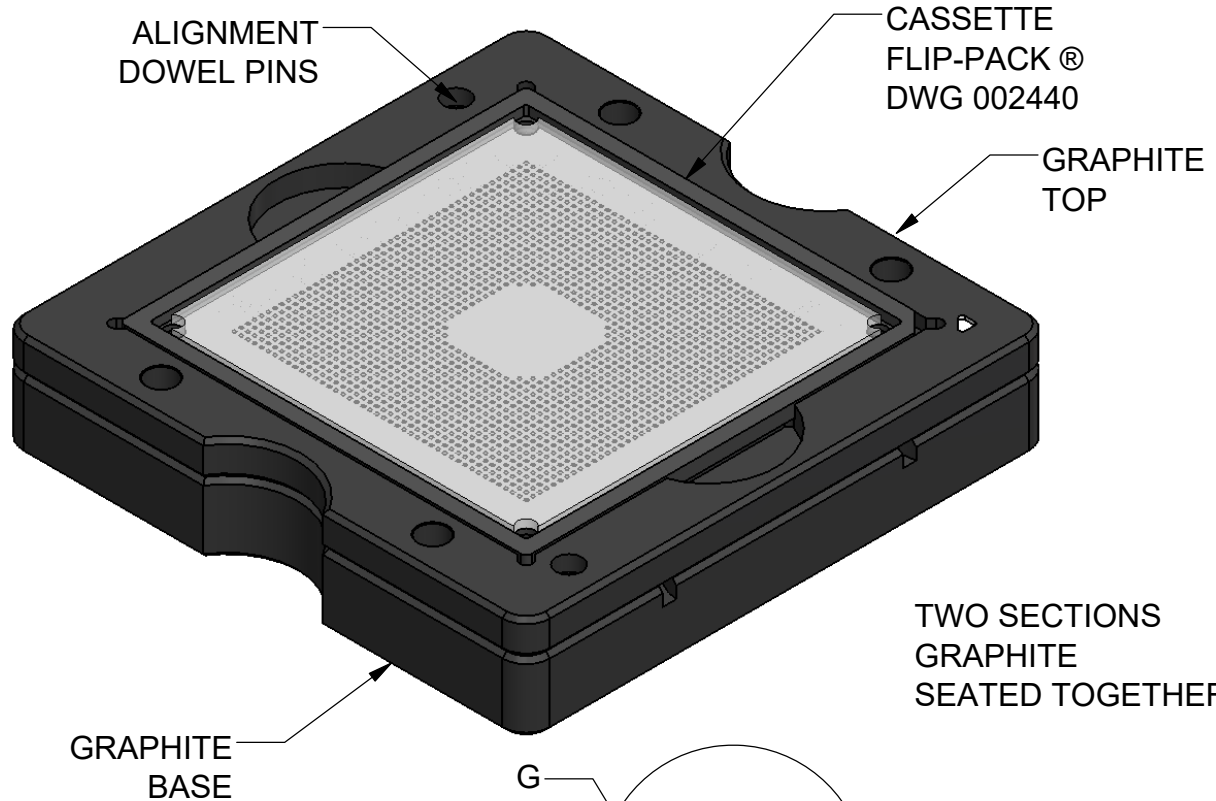

DETAIL G
SCALE 4 : 1

TWO SECTIONS
GRAPHITE
SEATED TOGETHER

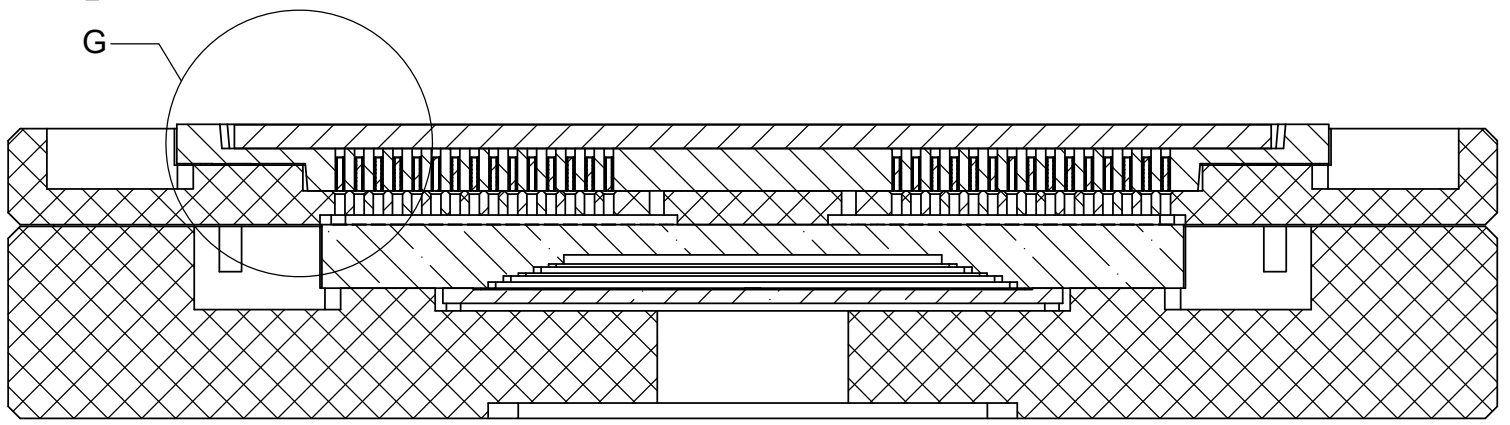

SECTION F-F
SCALE 2 : 1

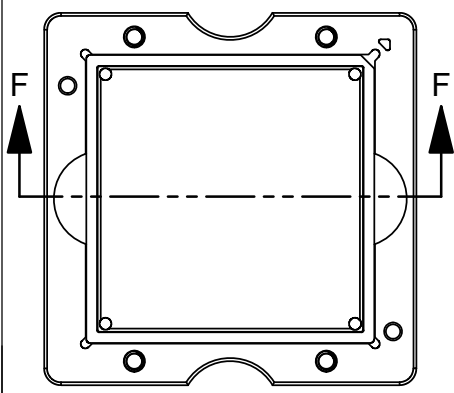

SCALE= 1:2

TopLine®			
TITLE C7-GRAPHITE-1752-RU GRAPHITE TOOL			
SCALE 1:1	SIZE A	DRAWING NO. 724482	REV A
DO NOT SCALE DRAWING			SHEET 7 OF 14

STACK-UP DIAGRAM

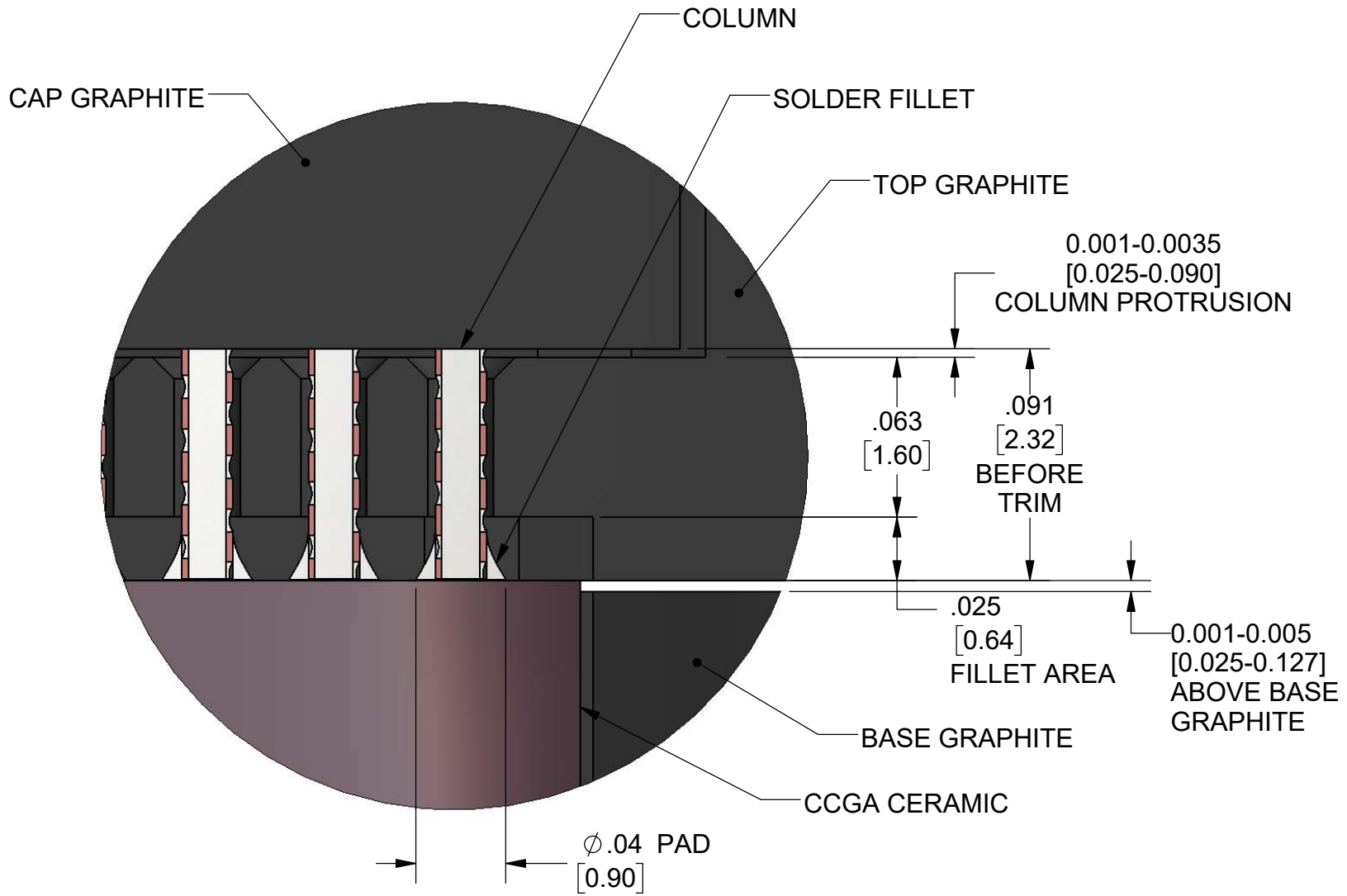

DETAIL Q
SEE SHEET 11

NOTES:
1) DIMENSIONS: MM [INCH].

TopLine®			
TITLE C7-GRAPHITE-1752-RU GRAPHITE TOOL			
SCALE 16:1	SIZE A	DRAWING NO. 724482	REV A
DO NOT SCALE DRAWING			SHEET 8 OF 14

EXPLODED SIDE VIEW

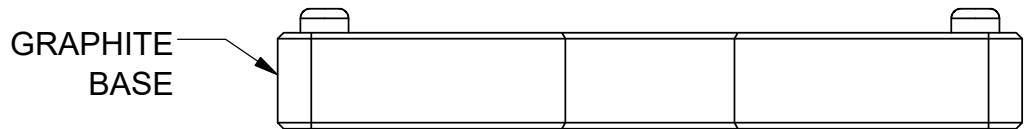
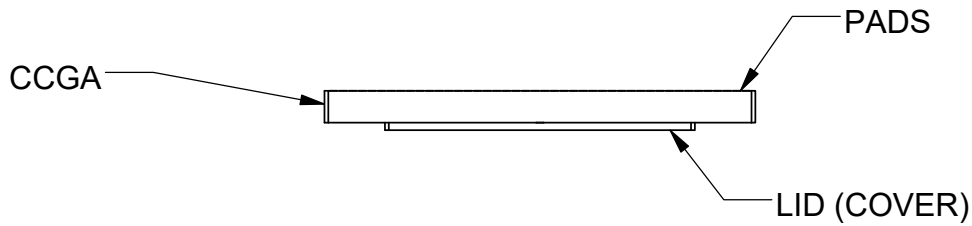
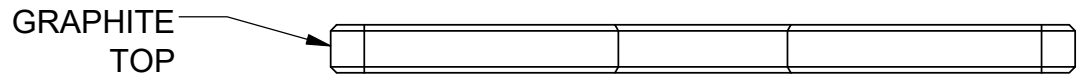
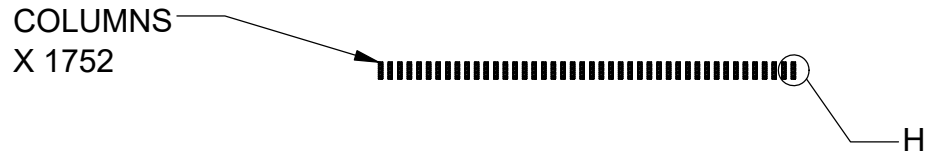
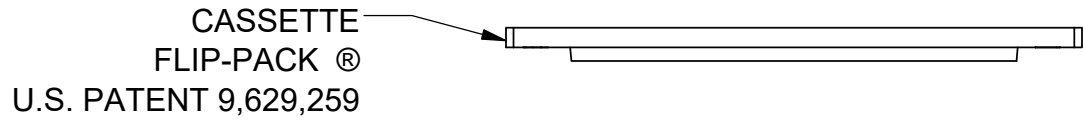

DETAIL H
SCALE 25 : 1

TopLine ®			
TITLE C7-GRAPHITE-1752-RU GRAPHITE TOOL			
SCALE 1:1	SIZE A	DRAWING NO. 724482	REV A
DO NOT SCALE DRAWING		SHEET 9 OF 14	

EXPLODED ISOMETRIC VIEW

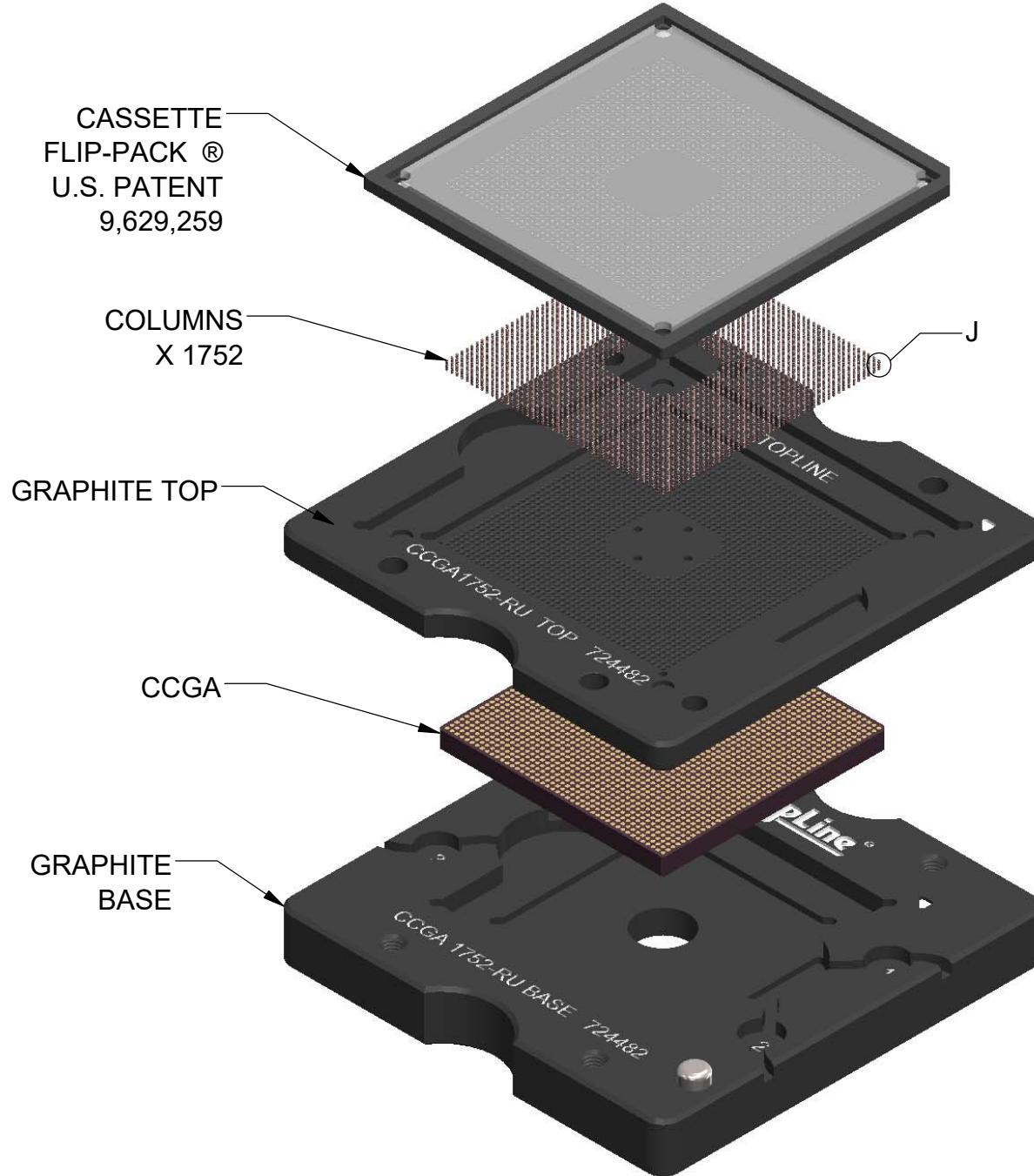

DETAIL J
SCALE 25 : 1

TopLine®			
TITLE C7-GRAPHITE-1752-RU GRAPHITE TOOL			
SCALE 0.85:1	SIZE A	DRAWING NO. 724482	REV A
DO NOT SCALE DRAWING			SHEET 10 OF 14

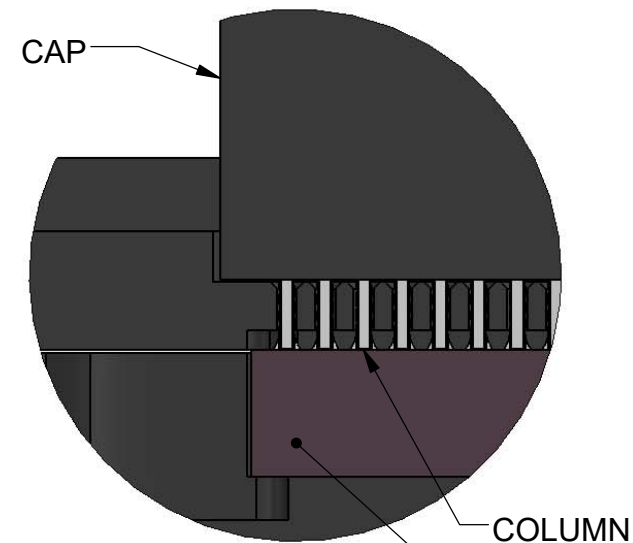
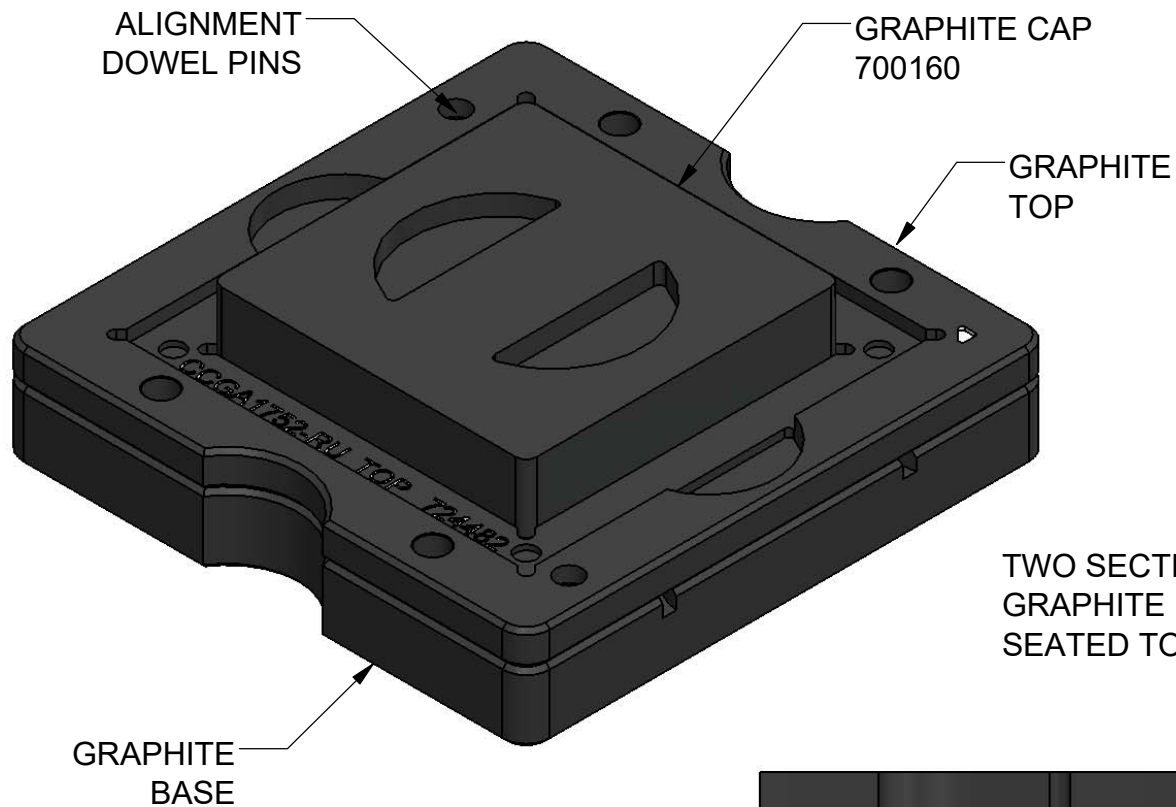

TWO SECTIONS
GRAPHITE
SEATED TOGETHER

DETAIL L
SCALE 4 : 1

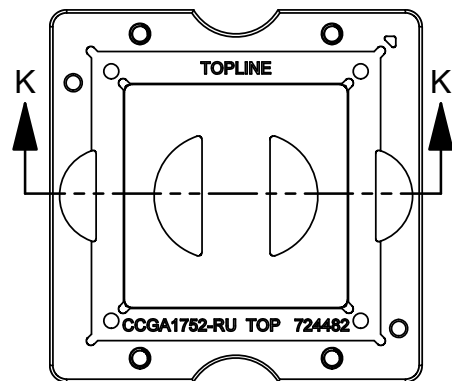

SCALE= 1:2

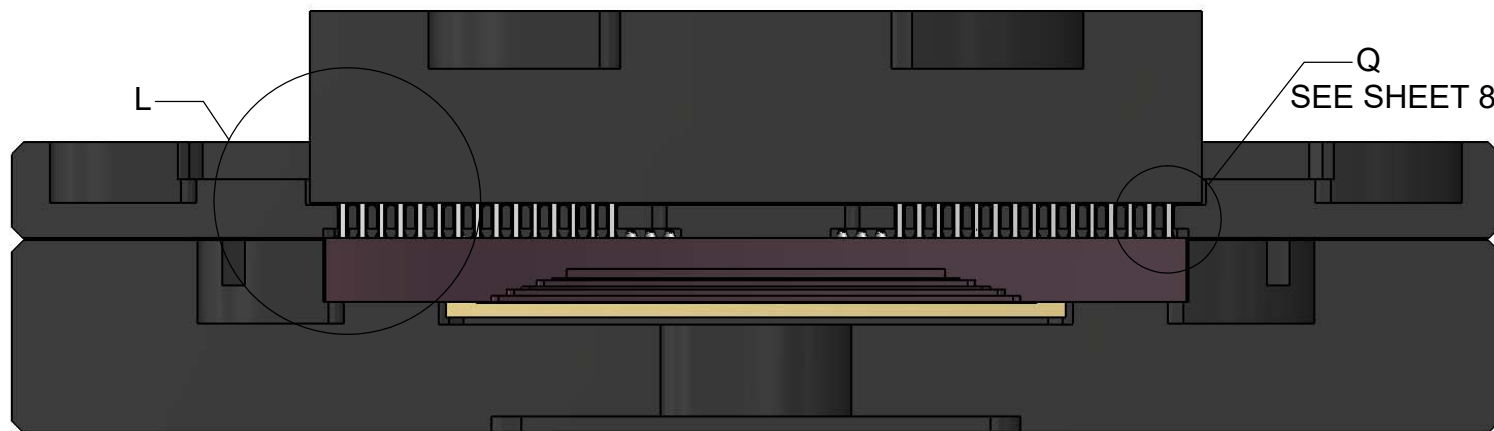

SECTION K-K
SCALE 2 : 1

TopLine [®]			
TITLE C7-GRAPHITE-1752-RU GRAPHITE TOOL			
SCALE 1:1	SIZE A	DRAWING NO. 724482	REV A
DO NOT SCALE DRAWING			SHEET 11 OF 14

EXPLODED SIDE VIEW

GRAPHITE CAP
700160



GRAPHITE
TOP

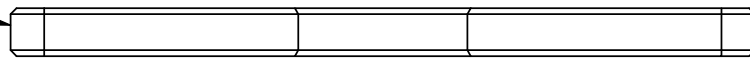

COLUMNS
X 1752

CCGA

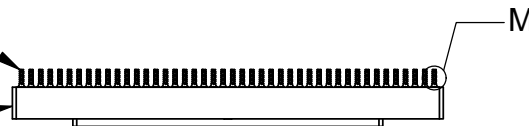

GRAPHITE
BASE

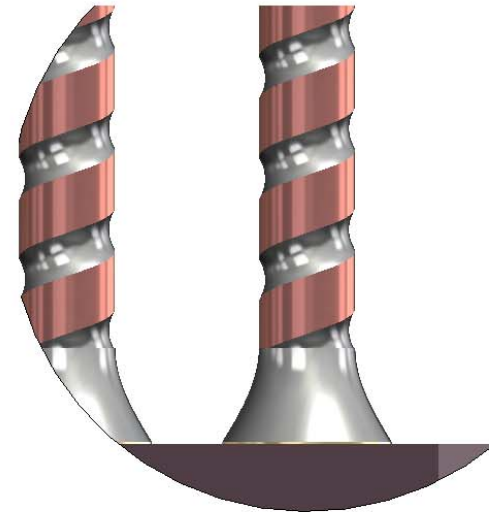
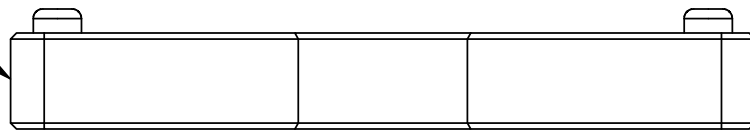

DETAIL M
SCALE 25 : 1

Sn63Pb37 FILLET
AFTER REFLOW

TopLine [®]			
TITLE C7-GRAPHITE-1752-RU GRAPHITE TOOL			
SCALE 1:1	SIZE A	DRAWING NO. 724482	REV A
DO NOT SCALE DRAWING			SHEET 12 OF 14

EXPLODED ISOMETRIC VIEW

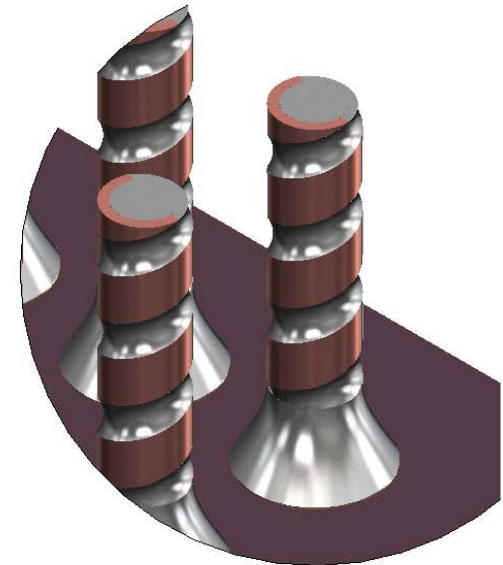
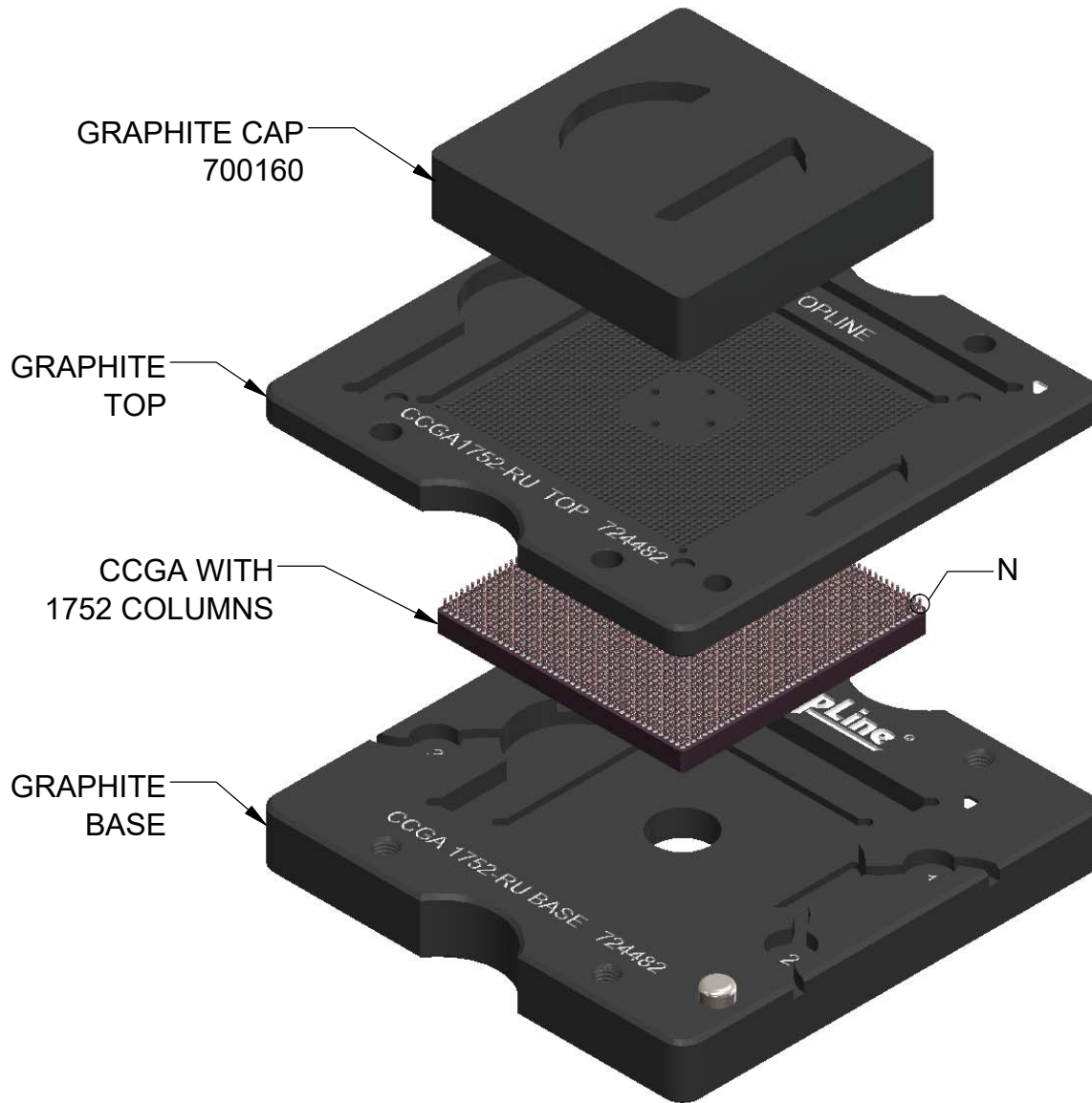

DETAIL N
SCALE 25 : 1
Sn63Pb37 FILLET
AFTER REFLOW

TopLine[®]			
TITLE C7-GRAPHITE-1752-RU GRAPHITE TOOL			
SCALE 0.85:1	SIZE A	DRAWING NO. 724482	REV A
DO NOT SCALE DRAWING			SHEET 13 OF 14

CAP SCREW DWG 704051

MODELS

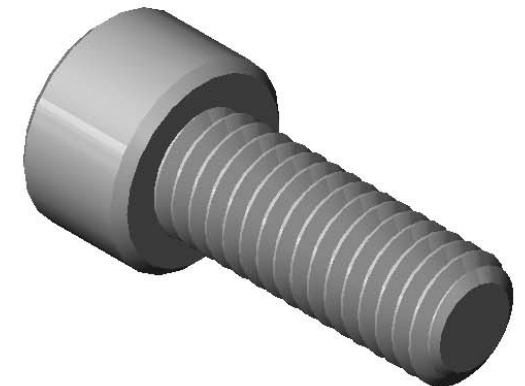
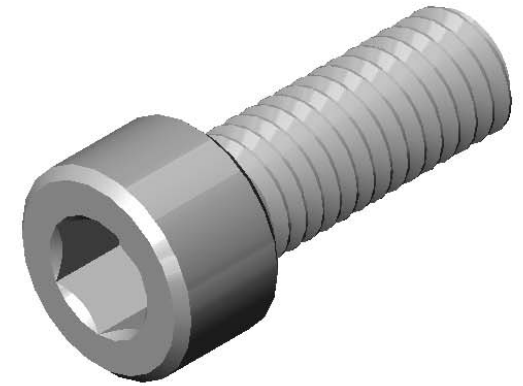
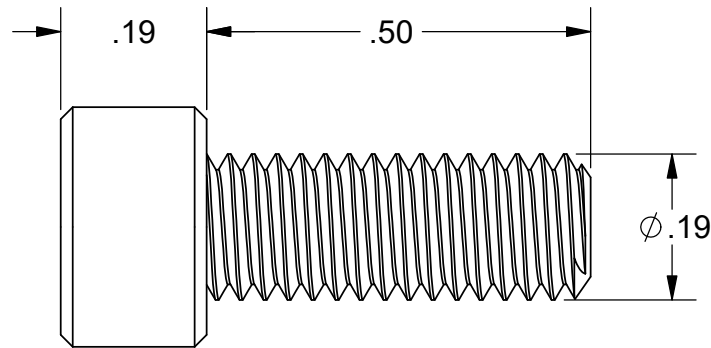
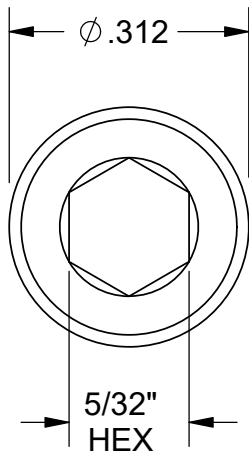

NOTES:

- 1) DIMENSIONS: INCH (UNLESS OTHERWISE SPECIFIED).
- 2) MATERIAL: SEE TABLE.
- 3) THREAD: SEE TABLE.
- 4) COLOR: STAINLESS.

DRILL TABLE

MATERIAL	THREAD	MAX OD	TAP DRILL START HOLE	CL HOLE CLOSE FIT	DWG
STAINLESS	10-32	0.190"	0.156"	0.206"	704051

TopLine[®]

TITLE C7-GRAPHITE-1752-RU GRAPHITE TOOL			
SCALE 4:1	SIZE A	DRAWING NO. 724482	REV A
DO NOT SCALE DRAWING			SHEET 14 OF 14