

# EXPLODED VIEW

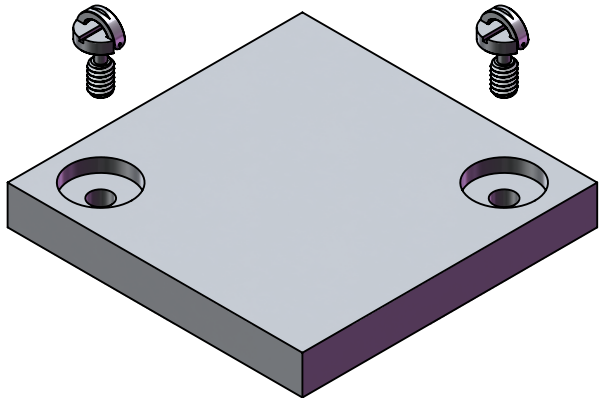

D-RING SCREW (SEE PAGE 8)

TOP COVER (SEE PAGE 3)

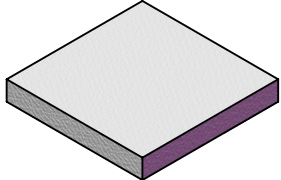

FOAM CUSHION (SEE PAGE 5)

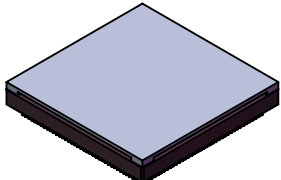

CCGA (SEE PAGE 7)

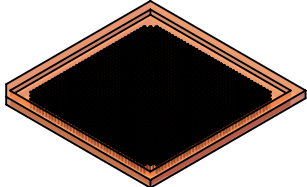

EMPTY PIN-PACK™ INSERT (SEE PAGE 6)

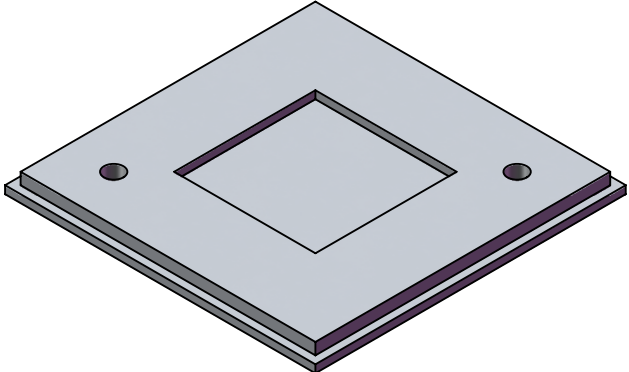

BASE (SEE PAGE 4)

APPROVALS	DATE	<b>TopLine®</b>			
DRAWN T. Au	11/05/14				
ENG M. Hart	11/05/14	TITLE WP4-CCGA1752 4" TRAY VAULT			
MFG					
QA		SCALE	SIZE	DRAWING NO.	REV
CUST		1:1.75	A	140040	A
REVISED		DO NOT SCALE DRAWING			SHEET 1 OF 8

# SIDE VIEW ELEVATION

CCGA 1752

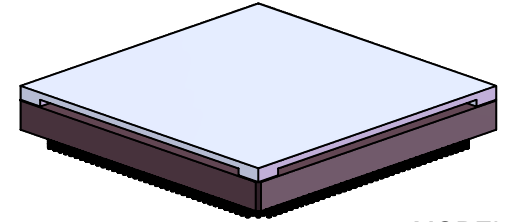

MODEL

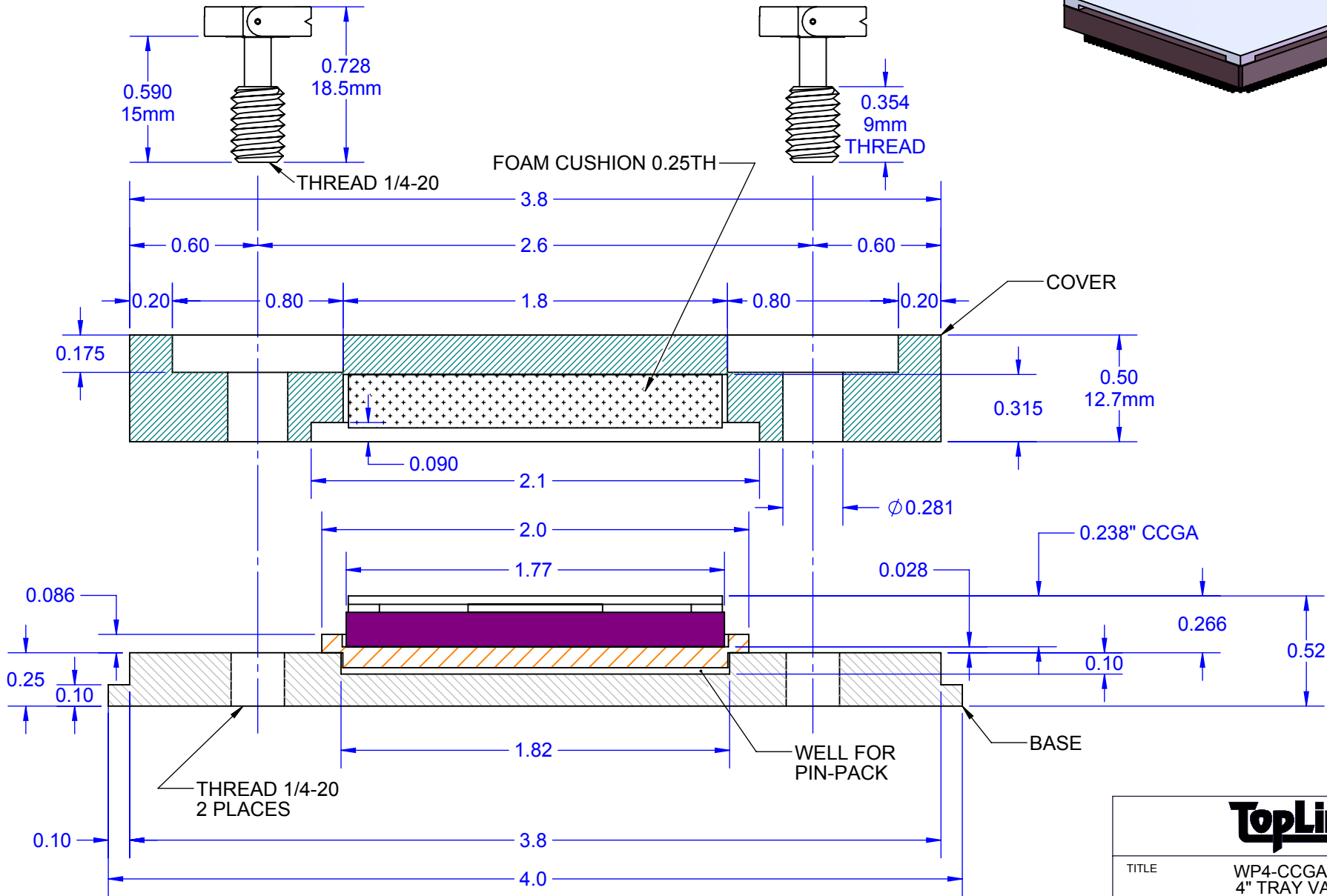

<b>TopLine®</b>			
TITLE		WP4-CCGA1752 4" TRAY VAULT	
SCALE	SIZE	DRAWING NO.	REV
1:1	A	140040	A
DO NOT SCALE DRAWING			SHEET 2 OF 8

**TOP**

**COVER**

**BOTTOM**

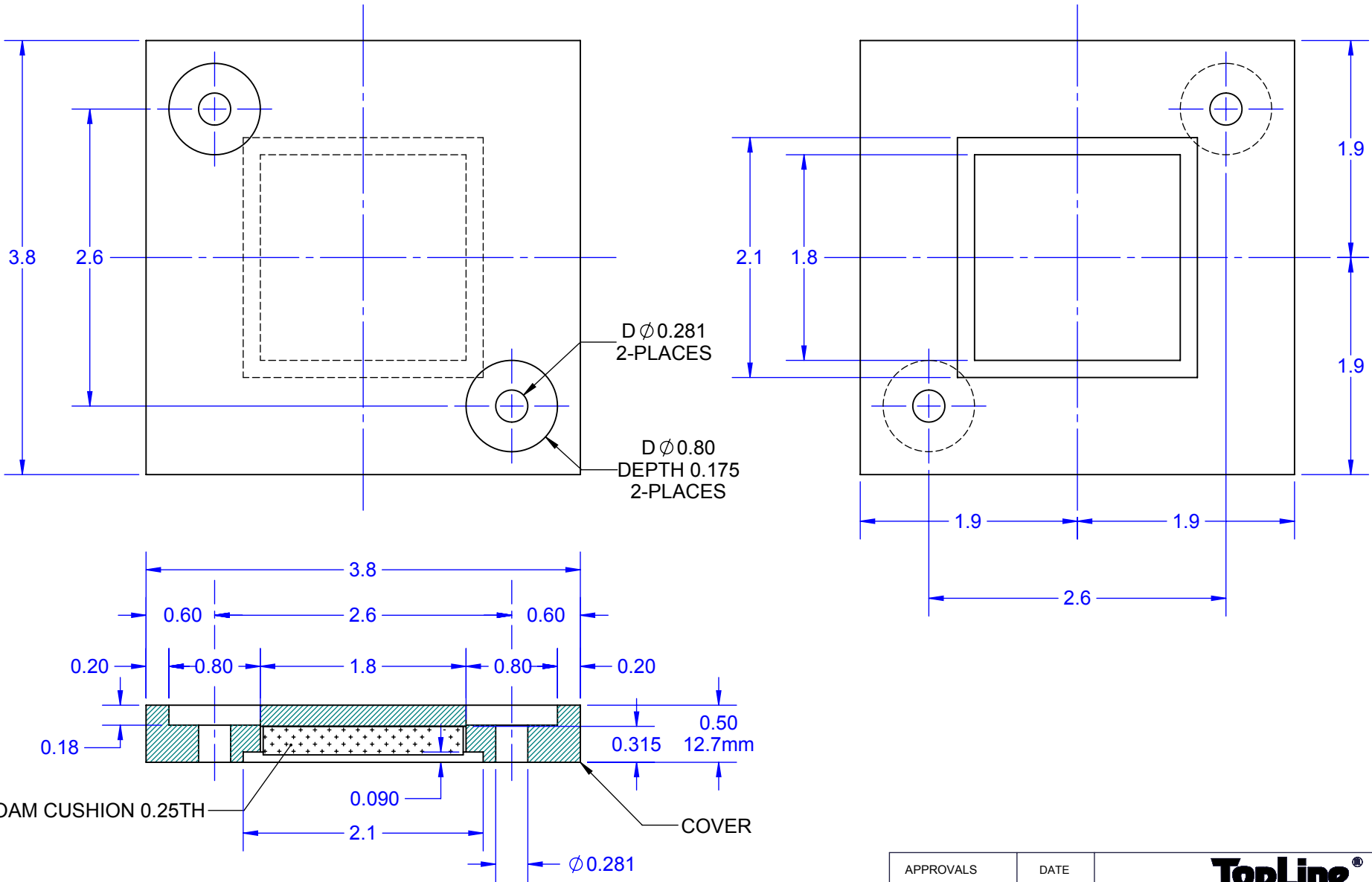

- NOTES:**  
 1. DIMENSIONS in INCHES UNLESS OTHERWISE SHOWN.  
 2. MATERIAL: ALUMINUM.

APPROVALS	DATE	<b>TopLine®</b>			
DRAWN T.Au	11/05/14				
ENG M. Hart	11/05/14	TITLE		WP4-CCGA1752 4" TRAY VAULT	
MFG		SCALE	SIZE	DRAWING NO.	REV
QA		1:1.25	A	140040	A
CUST		DO NOT SCALE DRAWING			SHEET 3 OF 8
REVISED					

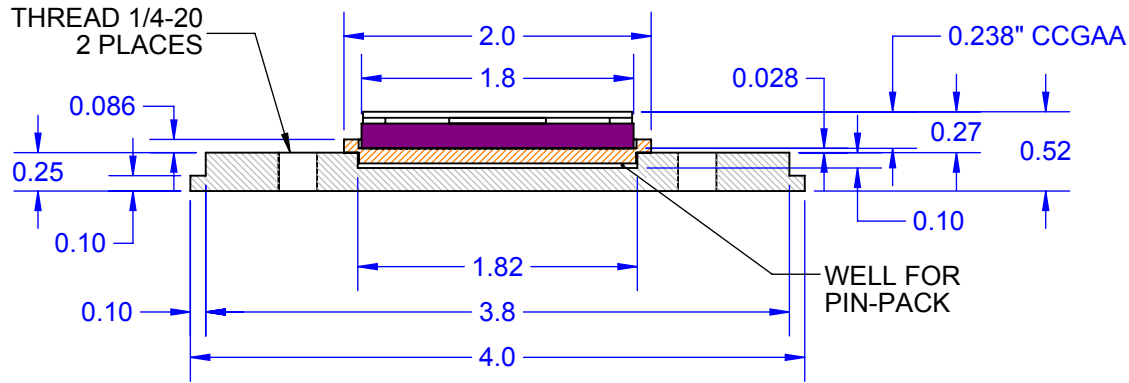
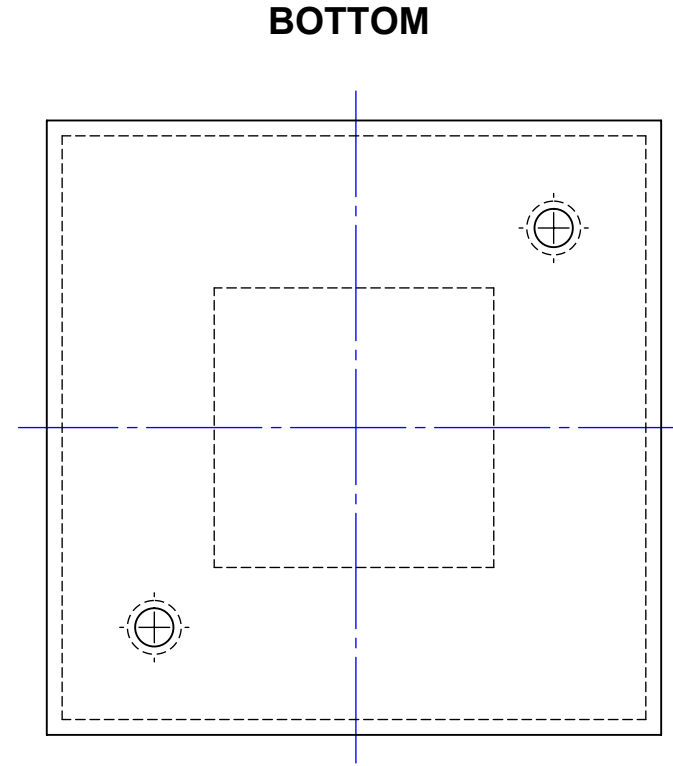
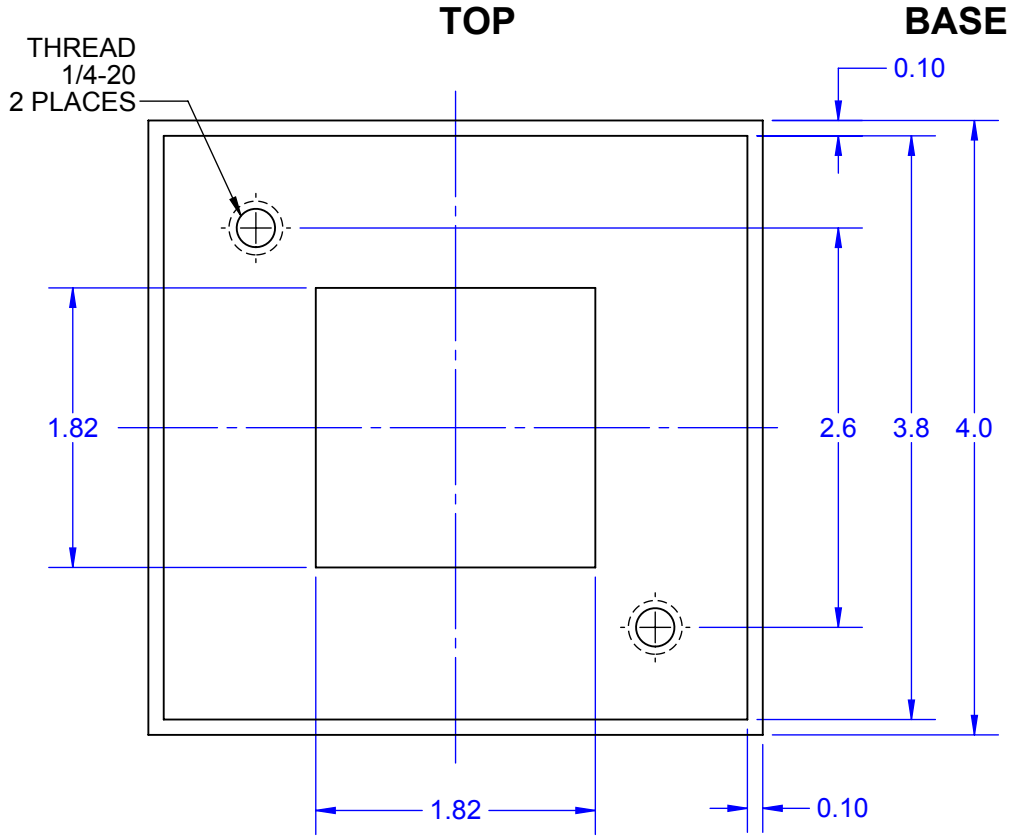

- NOTES:  
 1. DIMENSIONS in INCHES UNLESS OTHERWISE SHOWN.  
 2. MATERIAL: ALUMINUM.

<b>TopLine®</b>			
TITLE		WP4-CCGA1752 4" TRAY VAULT	
SCALE	SIZE	DRAWING NO.	REV
1:1.5	A	140040	A
DO NOT SCALE DRAWING			SHEET 4 OF 8

**FOAM CUSHION**

**TOP**

**BOTTOM**

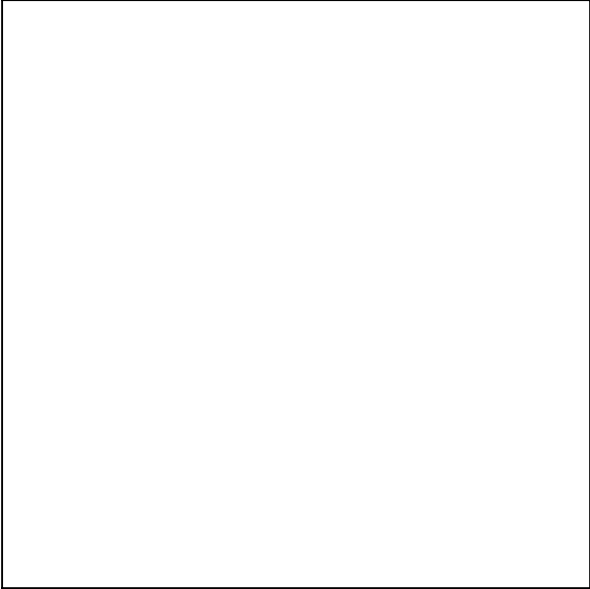
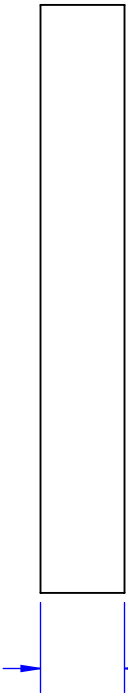
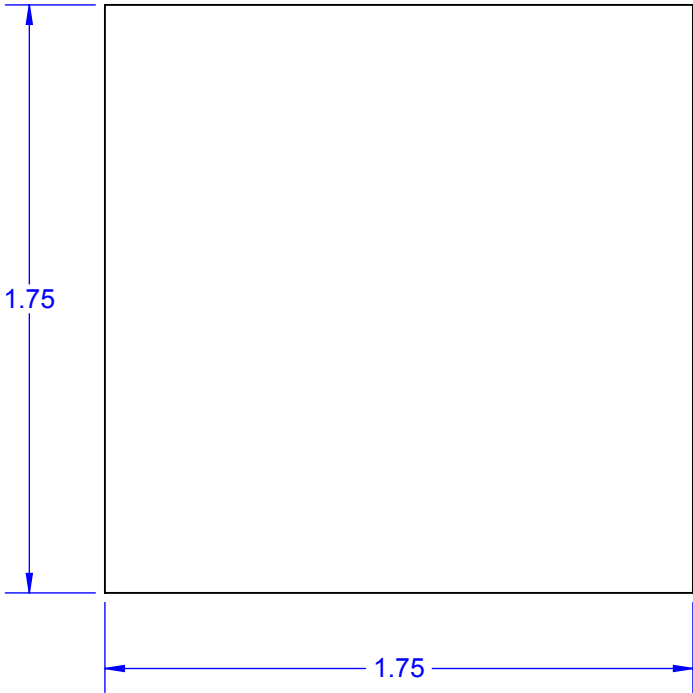

NOTES:  
1. DIMENSIONS in INCHES.  
2. MATERIAL: ESD FOAM CUSHION.

<b>TopLine®</b>			
TITLE		WP4-CCGA1752 4" TRAY VAULT	
SCALE	SIZE	DRAWING NO.	REV
1:1.5	A	140040	A
DO NOT SCALE DRAWING			SHEET 5 OF 8

**SIDE**

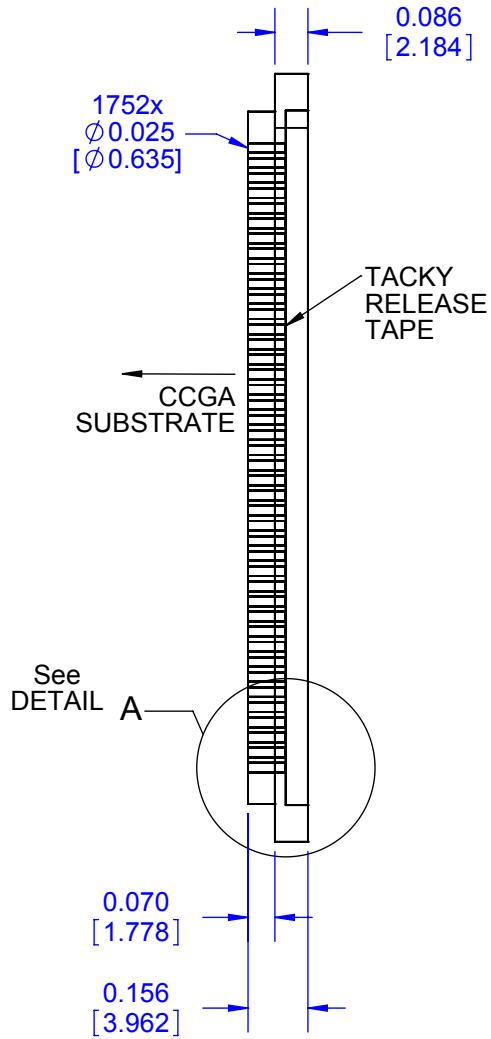

**TOP VIEW**

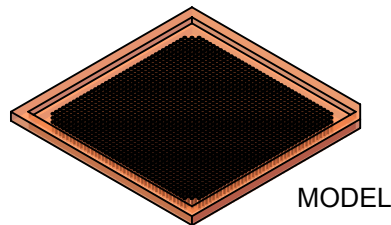
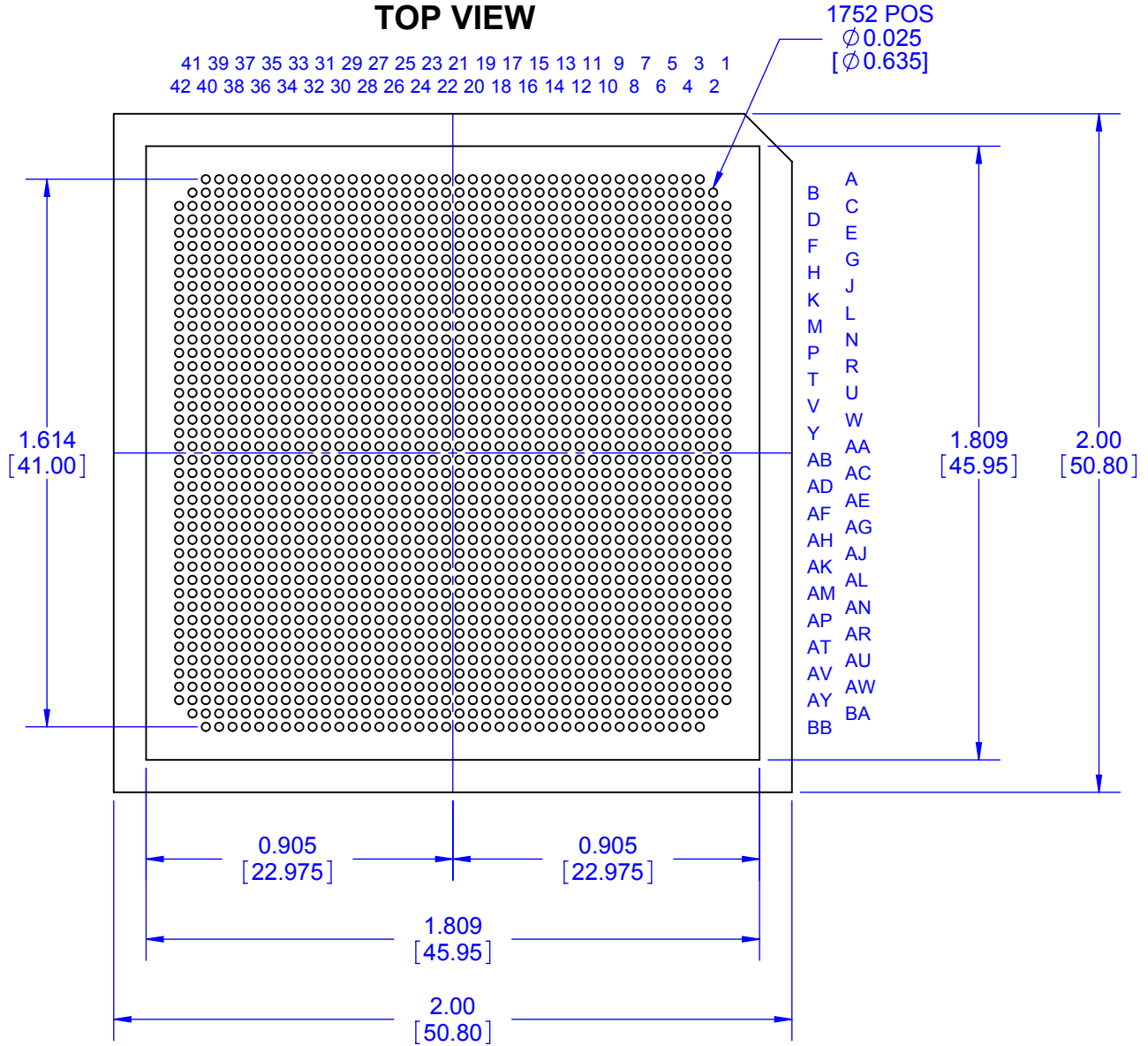

NOTES:  
1. DIMENSIONS INCHES [MM].  
2. SHOWN WITH MAXIMUM ARRAY.

<b>TopLine®</b>			
TITLE PP1752 PIN-PACK™ CCGA COLUMN CARRIER			
SCALE 2:1	SIZE A	DRAWING NO. 140040	REV A
DO NOT SCALE DRAWING			SHEET 6 OF 8

### BOTTOM VIEW

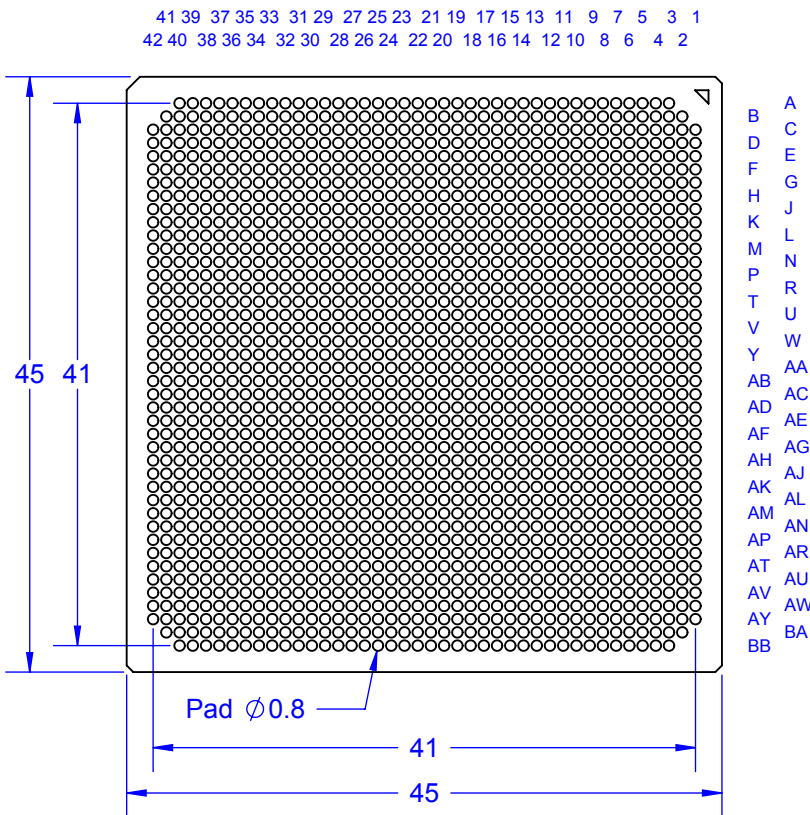

A  
B  
C  
D  
E  
F  
G  
H  
J  
K  
L  
M  
N  
P  
R  
T  
U  
V  
W  
Y  
AA  
AB  
AD  
AE  
AF  
AG  
AH  
AJ  
AK  
AL  
AM  
AN  
AR  
AU  
AV  
AW  
AY  
BA

Pb80/Sn20  
Cu RIBBON  
COLUMNS

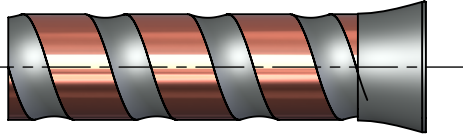

### TOP VIEW

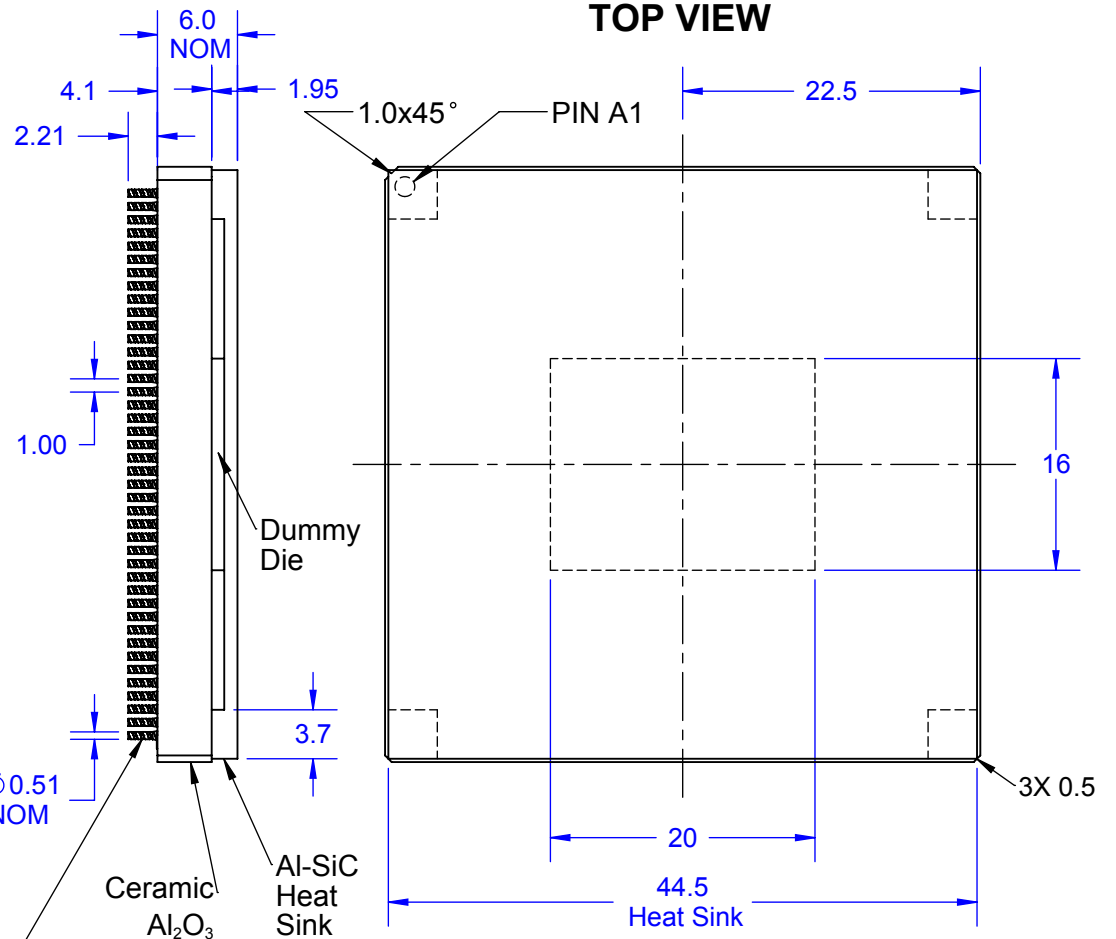

Notes: (Unless Otherwise Specified).

- 1) DIMENSIONS ARE IN mm.
- 2) SHOWN WITH Pb80/Sn20 Cu RIBBON COLUMNS.
- 3) PART NUMBER CCGA1752T1.0-DC427CN.

#### PART NUMBER OPTIONS

PART NUMBER	DUMMY DIE	SOLDER PIN
CCGA1752T1.0-DC427CN	YES	Pb80/Sn20 Cu RIBBON
CCGA1752T1.0A-DC427CN	YES	Pb90/Sn10
CCGA1752T1.0M-DC427CN	YES	Micro-Coil
CLGA1752T1.0-DC427CN	YES	NONE
CLGA1752T1.0-DC427	NO	NONE

APPROVALS	DATE				
DRAWN T.Au	11/05/14				
ENG M. Hart	11/05/14	TITLE CCGA1752T1.0-DC427CN DUMMY COLUMN GRID ARRAY			
MFG		SCALE 1.75:1	SIZE A	DRAWING NO. 140040	REV A
QA		DO NOT SCALE DRAWING			SHEET 7 OF 8
CUST					
REVISED					

# D-RING THUMB SCREW

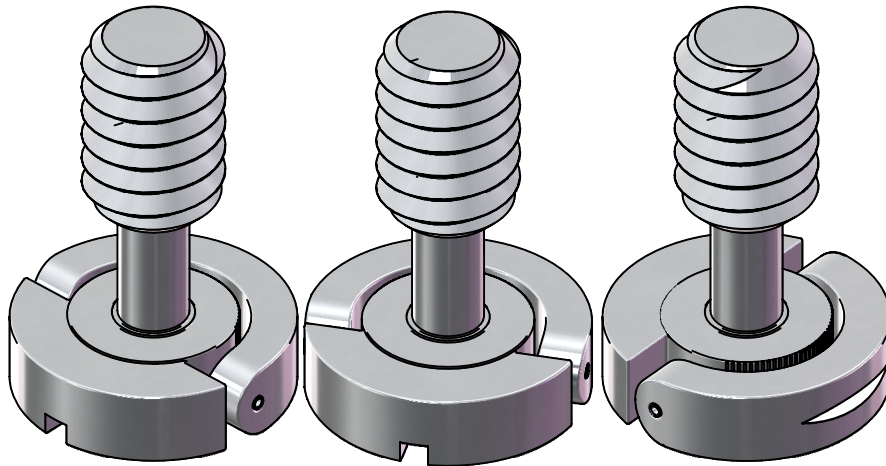
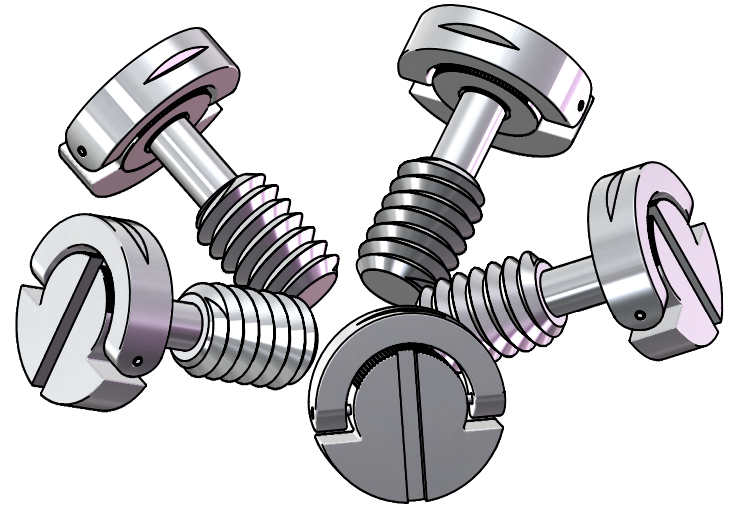
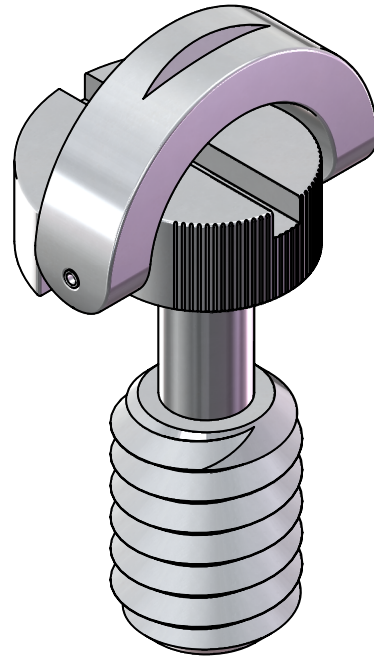
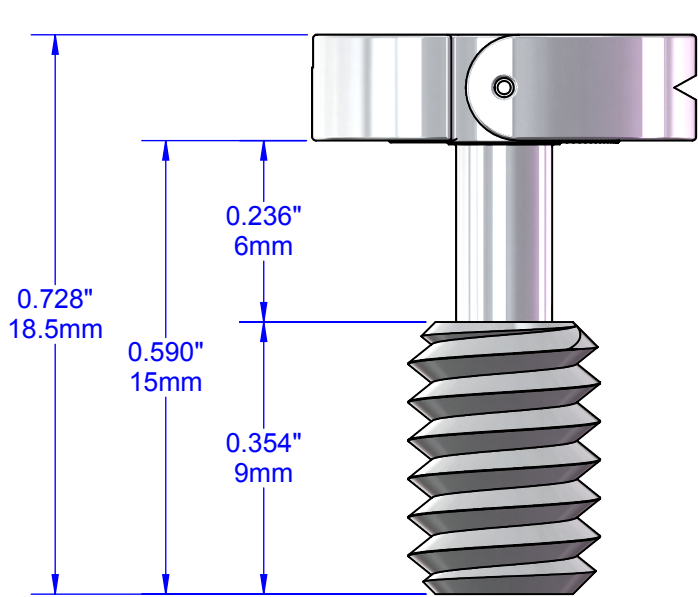

<b>TopLine®</b>			
TITLE		WP4-CCGA1752 4" TRAY VAULT	
SCALE	SIZE	DRAWING NO.	REV
1:1.5	A	140040	A
DO NOT SCALE DRAWING			SHEET 8 OF 8