

EXPLODED VIEW CCGA TRAY BOX SYSTEM 1.0MM PITCH

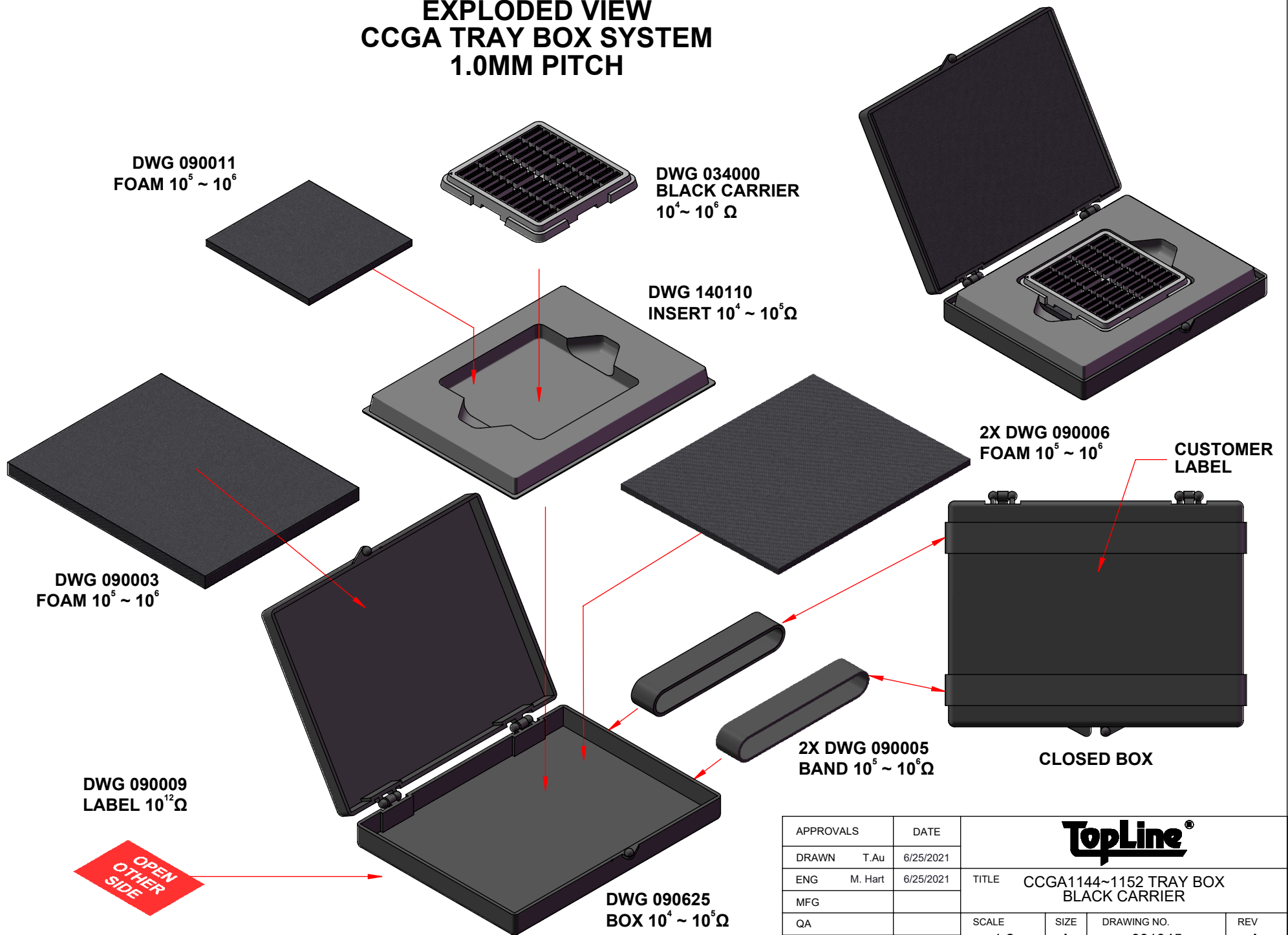

APPROVALS	DATE	TopLine®			
DRAWN T. Au	6/25/2021				
ENG M. Hart	6/25/2021	TITLE CCGA1144~1152 TRAY BOX BLACK CARRIER			
MFG		SCALE	SIZE	DRAWING NO.	REV
QA		1:2	A	931345	A
CUST		DO NOT SCALE DRAWING			SHEET 1 OF 13
REVISED					

**EXPLODED SIDE VIEW
PITCH 1.0mm**

CUSTOMER LABEL

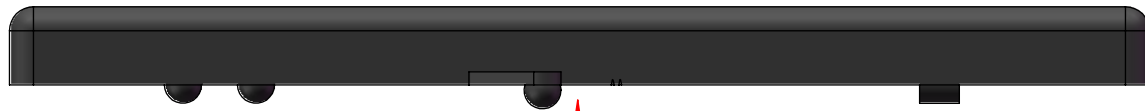

DWG 090625 BOX TOP



DWG 090003 FOAM (LOW PROFILE CCGA)
DWG 090006 FOAM (HIGH PROFILE CCGA)



CCGA COMPONENT



DWG 034000 CARRIER



DWG 090011 FOAM (OPTIONAL LOW PROFILE CCGA)



DWG 140110 INSERT



DWG 090006 FOAM
2X - LOW PROFILE CCGA
1X - HIGH PROFILE CCGA



DWG 090625
BOX BOTTOM

DWG 090009 LABEL

TopLine®

TITLE CCGA1144~1152 TRAY BOX
BLACK CARRIER

SCALE 1:2	SIZE A	DRAWING NO. 931345	REV A
--------------	-----------	-----------------------	----------

DO NOT SCALE DRAWING

SHEET 2 OF 13

MODEL
TOP

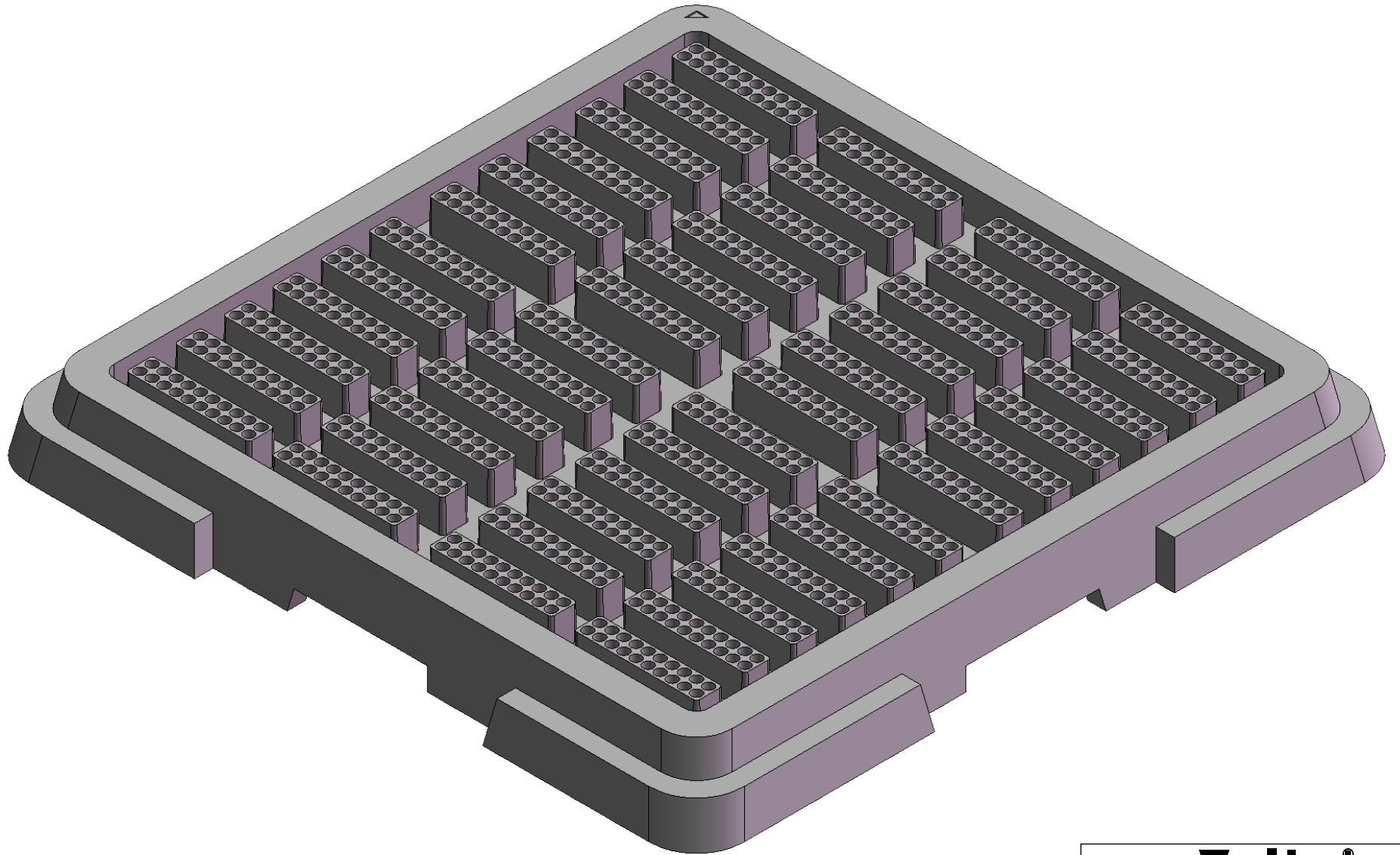

TopLine[®]

TITLE CCGA1144~1152 TRAY BOX
BLACK CARRIER

SCALE	SIZE	DRAWING NO.	REV
3:1	A	931345	A

DO NOT SCALE DRAWING

SHEET 3 OF 13

TOP

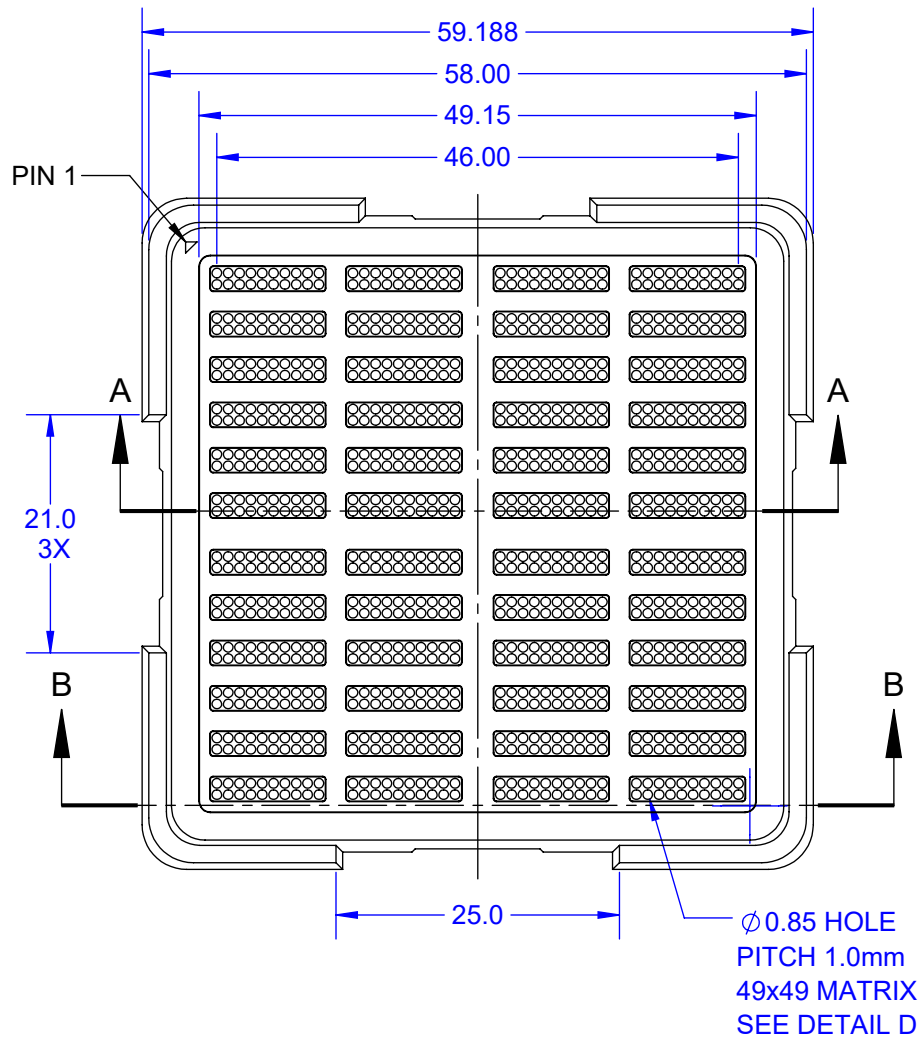

SIDE

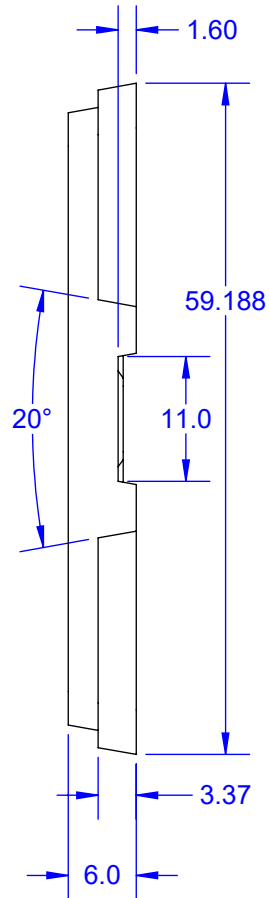

BOTTOM

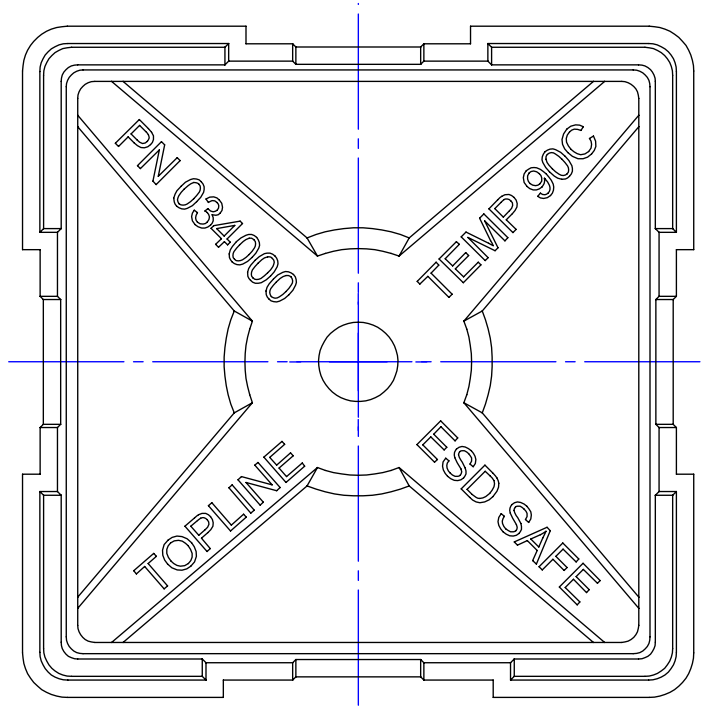

NOTES:

1. DIMENSION MM.
2. MATERIAL: CONDUCTIVE POLYCARBONATE.
3. TEMPERATURE 90°C MAX.
4. COLOR: BLACK.
5. PERMANENT ESD SAFE
SURFACE RESISTIVITY $10^4 \sim 10^6 \Omega$.

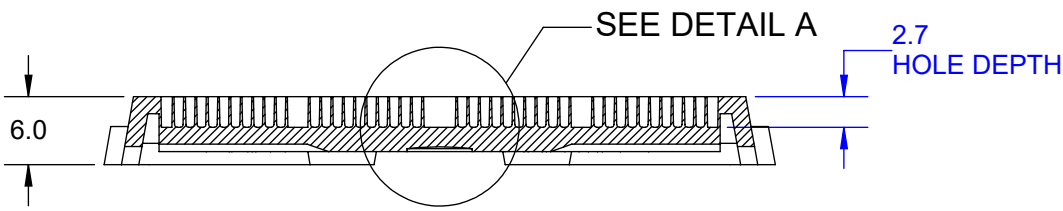

SECTION A-A

APPROVALS	DATE	TopLine®			
DRAWN T. Au	9/17/2021				
ENG M. Hart	9/17/2021	TITLE CCGA1144~1152 TRAY BOX BLACK CARRIER			
TOLERANCE	MFG	SCALE	SIZE	DRAWING NO.	REV
[X] MM	QA	3:2	A	931345	A
X.X = ±0.2	CUST	DO NOT SCALE DRAWING			SHEET 4 OF 13
X.XX = ±0.1	REVISED				

CCGA1140~1152
 COLUMNS 34x34
 35x35mm

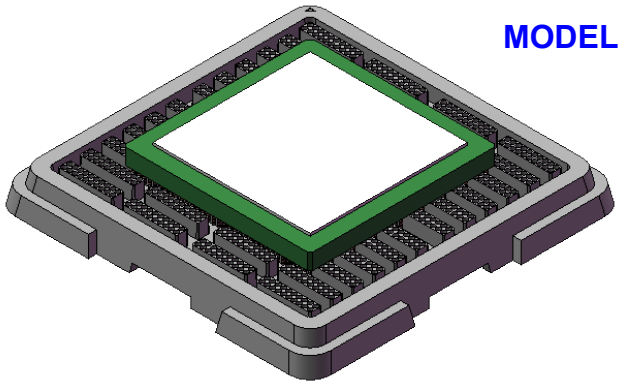
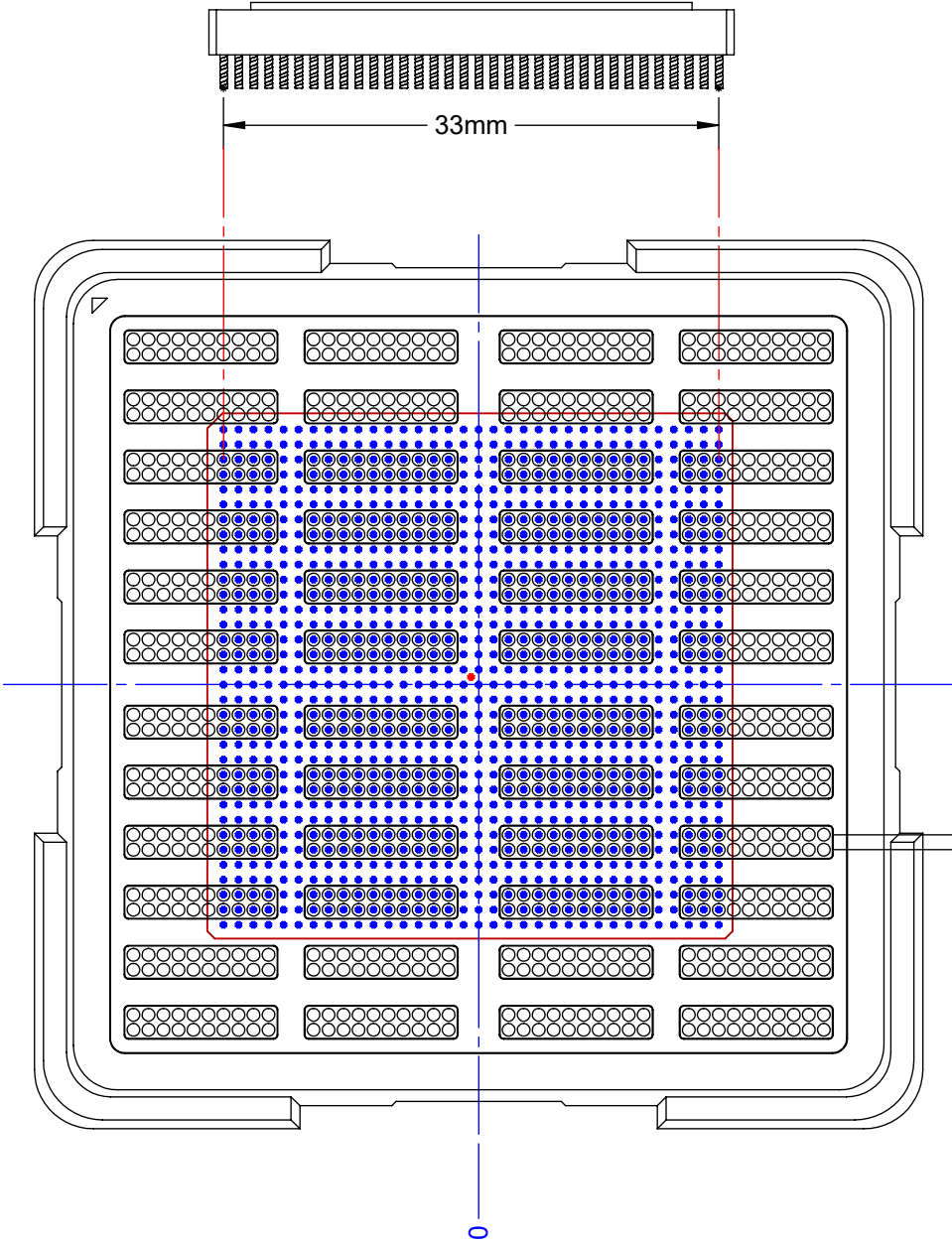

PITCH
 1.0mm TYP.

TopLine®			
TITLE CCGA1144~1152 TRAY BOX BLACK CARRIER			
SCALE 2:1	SIZE A	DRAWING NO. 931345	REV A
DO NOT SCALE DRAWING			SHEET 5 OF 13

TOP (OPEN)

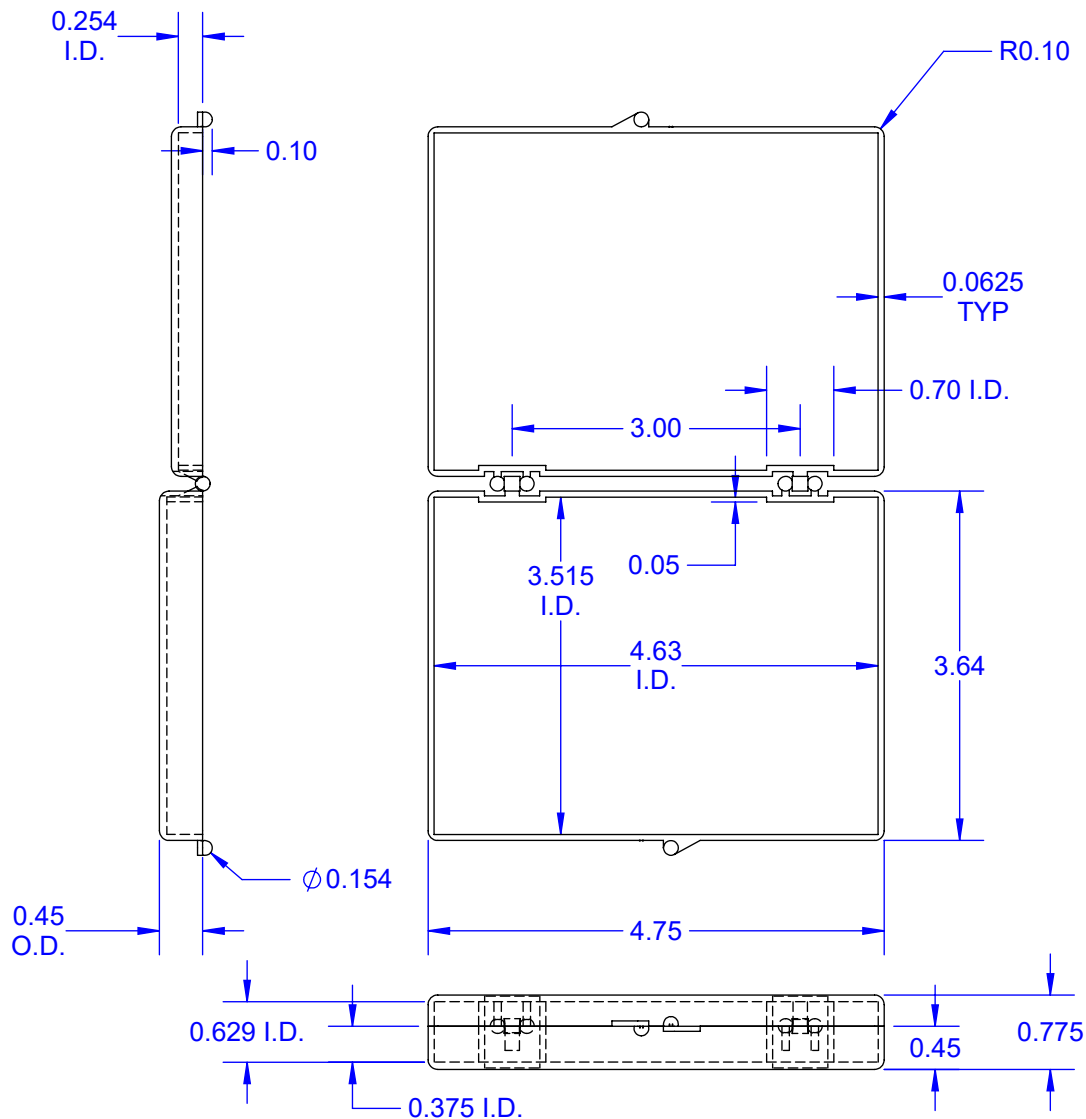

FRONT (CLOSED)

SIDE VIEW (OPEN)

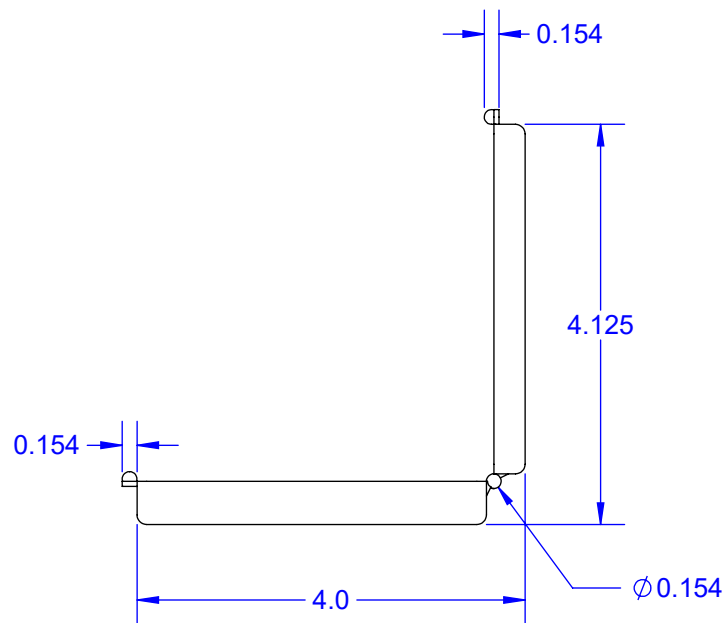

MODEL

Notes: (Unless Otherwise Specified).

- 1) SURFACE RESISTIVITY: $10^4 \sim 10^5 \Omega$.
- 2) MATERIAL: CARBON FILLED POLYPROPYLENE.
- 3) DIMENSIONS IN INCHES.

TopLine®			
TITLE		EC1-15mm EMPTY HINGE BOX	
SCALE	SIZE	DRAWING NO.	REV
1:2	A	090625	A
DO NOT SCALE DRAWING			SHEET 6 OF 13

TOP VIEW

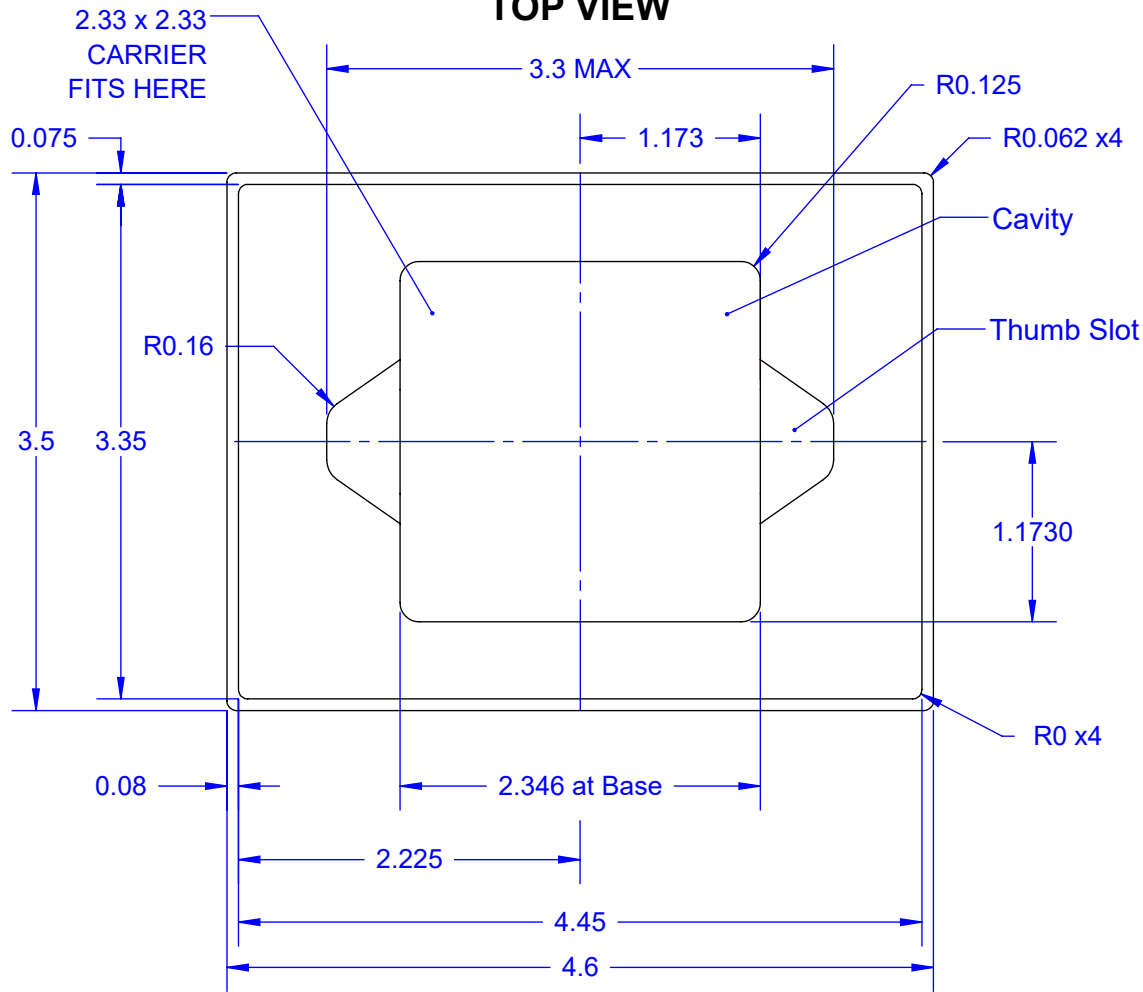

BOTTOM VIEW

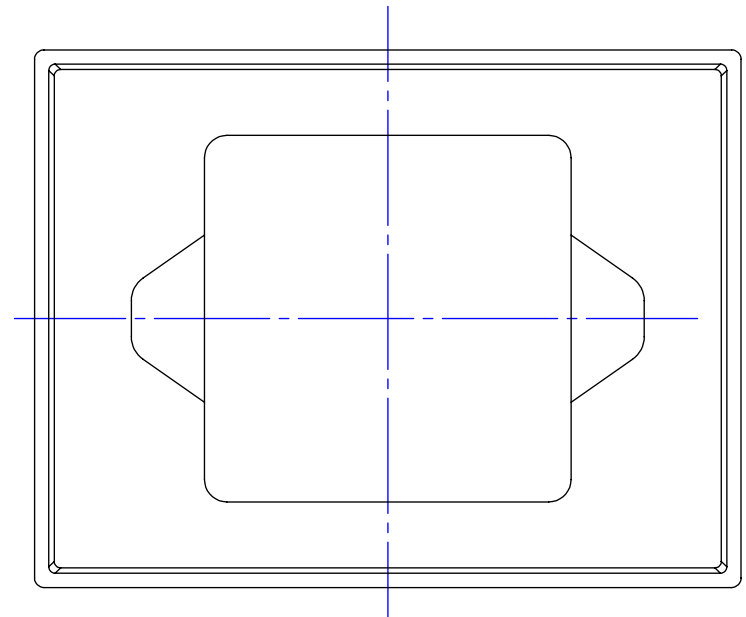

SIDE VIEW

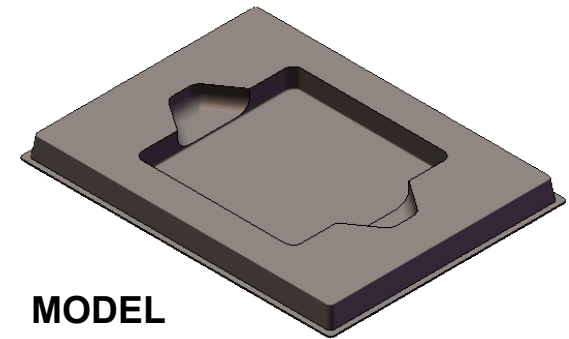
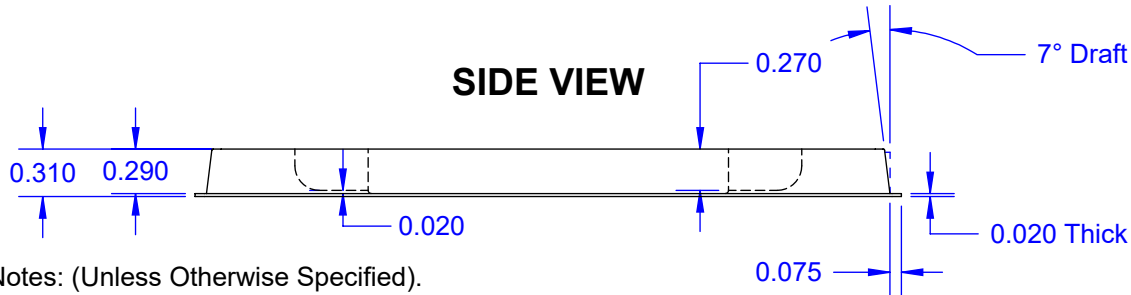

MODEL

Notes: (Unless Otherwise Specified).

- 1) DIMENSIONS: INCHES.
- 2) MATERIAL: CONDUCTIVE STYRENE.
- 3) SURFACE RESISTIVITY <math>< 10^4 \Omega</math>.

TopLine®

TITLE CCGA TRAY INSERT
FOR 4.625 x 3.5 HINGE BOX

SCALE	SIZE	DRAWING NO.	REV
2:2.5	A	140110	A

DO NOT SCALE DRAWING

SHEET 7 OF 13

TOP

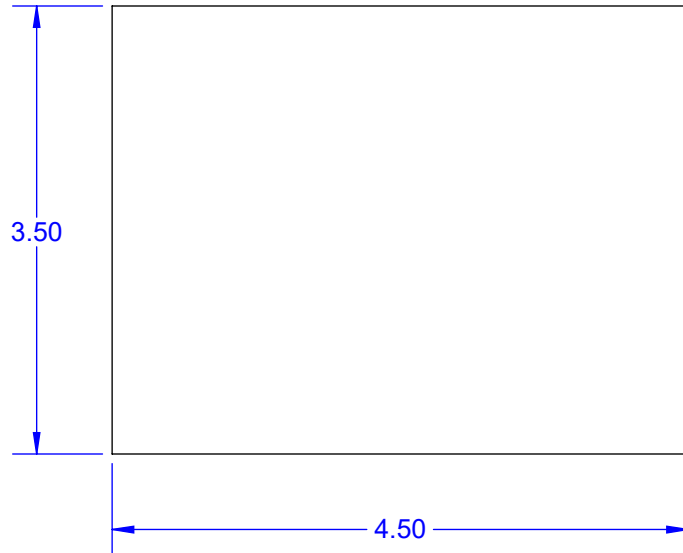

EDGE

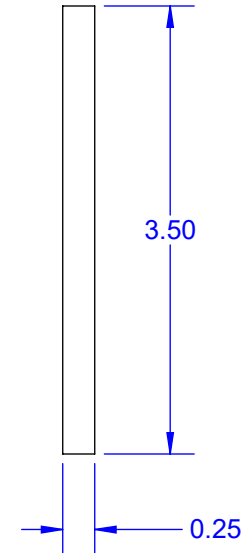

SIDE

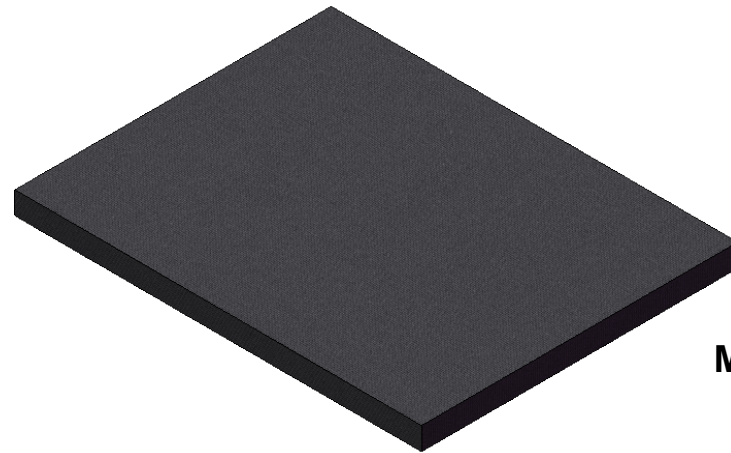
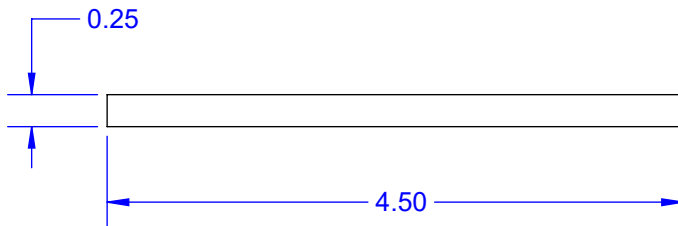

MODEL

- Notes: (Unless Otherwise Specified).
- 1) SURFACE RESISTIVITY: $10^5 \sim 10^6 \Omega$
 - 3) DENSITY 1.7 PFC Min.
 - 4) DIMENSIONS IN INCHES.

TopLine®			
TITLE		EC1-FOAM-SOFT-.25-A LOW DENSITY FOAM	
SCALE	SIZE	DRAWING NO.	REV
1:1.5	A	090003	A
DO NOT SCALE DRAWING			SHEET 8 OF 13

TOP

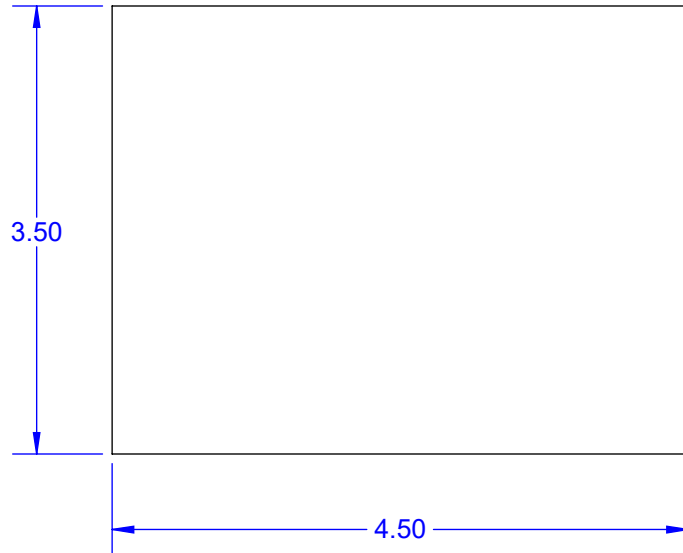

EDGE

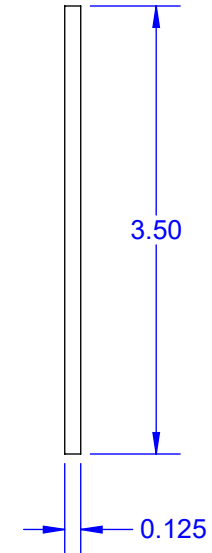

SIDE

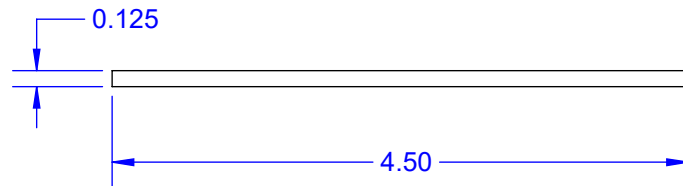

MODEL

- Notes: (Unless Otherwise Specified).
1) SURFACE RESISTIVITY: $10^5 \sim 10^6 \Omega$
3) DENSITY 1.7 PFC Min.
4) DIMENSIONS IN INCHES.

TopLine®			
TITLE EC1-FOAM-SOFT-.125-A LOW DENSITY FOAM			
SCALE 1:1.5	SIZE A	DRAWING NO. 090006	REV A
DO NOT SCALE DRAWING			SHEET 9 OF 13

TOP

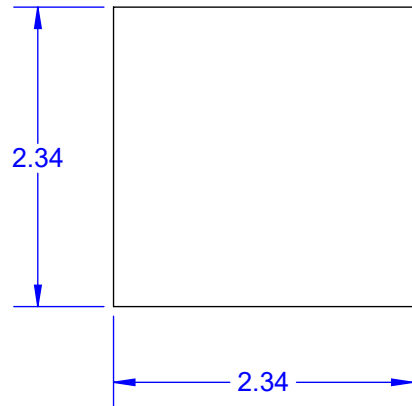

EDGE

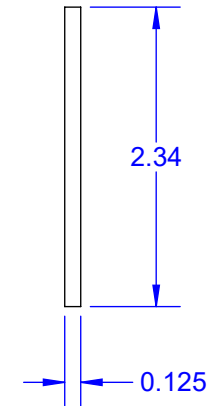

SIDE

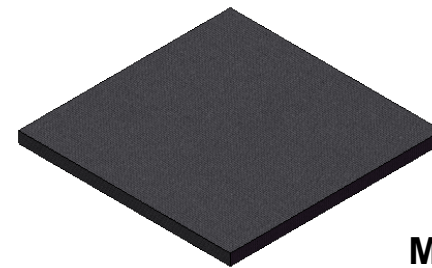
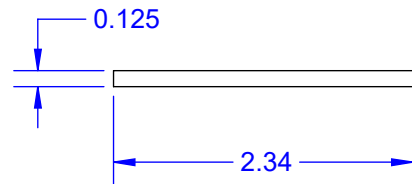

MODEL

- Notes: (Unless Otherwise Specified).
- 1) SURFACE RESISTIVITY: $10^5 \sim 10^6 \Omega$.
 - 2) SOFT CONDUCTIVE FOAM.
 - 3) DENSITY 1.7 PFC Min.

TopLine®			
TITLE		LOW DENSITY FOAM FOAM-SOFT-2.34A	
SCALE	SIZE	DRAWING NO.	REV
1:1.5	A	090011	A
DO NOT SCALE DRAWING			SHEET 10 OF 13

TOP

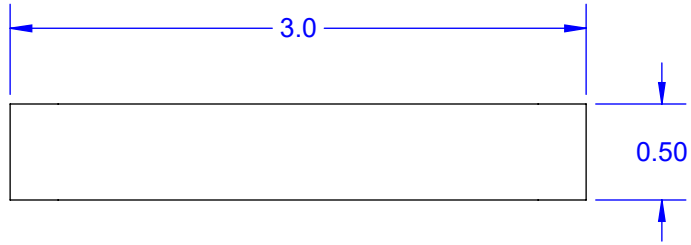

EDGE

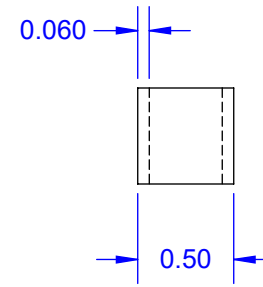

SIDE

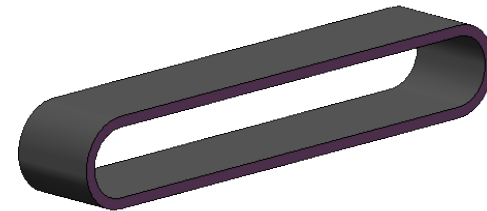
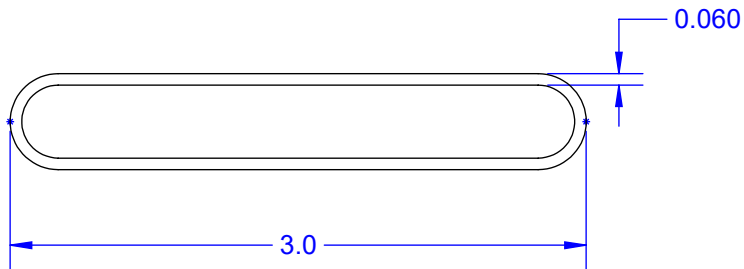

MODEL

Notes: (Unless Otherwise Specified).

1) SURFACE RESISTIVITY: $10^5 \sim 10^6$.

2) DIMENSIONS IN INCHES (RESTING POSITION).

TopLine®			
TITLE		RUBBER BAND-3.0-C BLACK CONDUCTIVE	
SCALE	SIZE	DRAWING NO.	REV
1:1	A	090005	A
DO NOT SCALE DRAWING			SHEET 11 OF 13

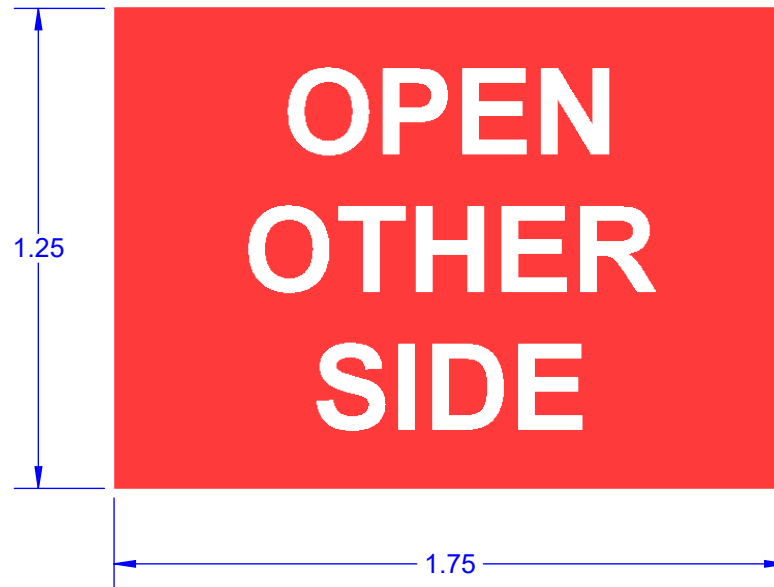

Notes: (Unless Otherwise Specified).

1. DIMENSIONS INCHES.
2. MATERIAL: PAPER LABEL WITH ADHESIVE.
3. COLOR: RED.
4. PURPOSE: IDENTIFY BOTTOM OF HINGE BOX.

TopLine®			
TITLE		LABEL FOR BOTTOM OF HINGE BOX	
SCALE	SIZE	DRAWING NO.	REV
2:1	A	090009	A
DO NOT SCALE DRAWING			SHEET 12 OF 13

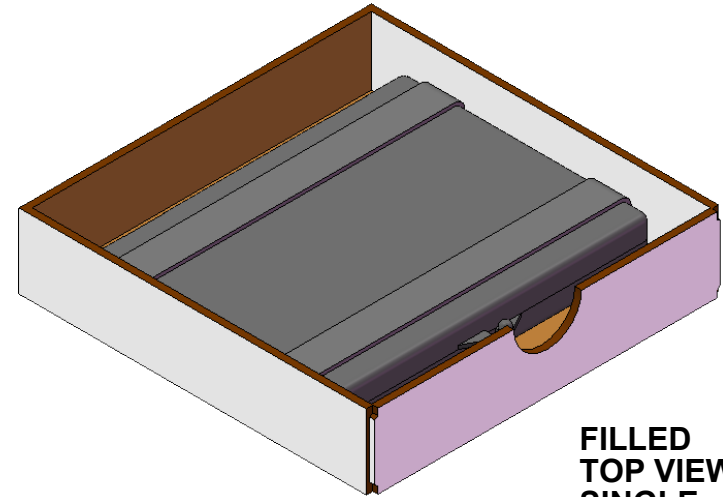
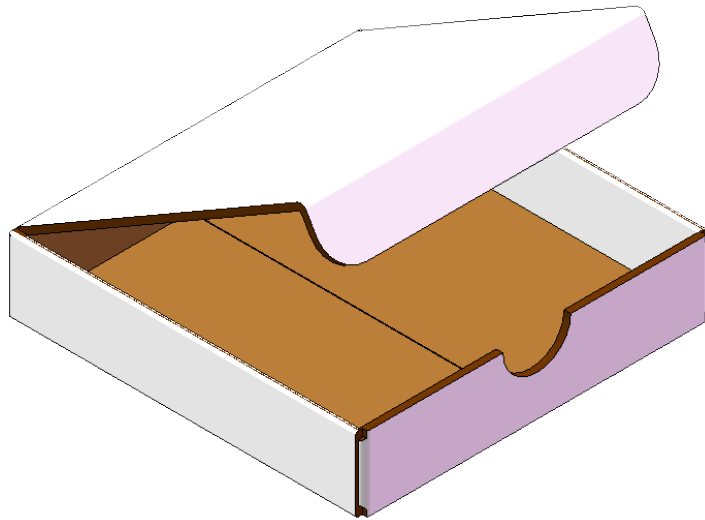

**FILLED
TOP VIEW
SINGLE**

Notes: (Unless Otherwise Specified).

1. DIMENSIONS INCHES.
2. MEASUREMENT INCLUDES RUBBER BANDS.
3. BOX SIZE SUBJECT TO CHANGE.

TopLine®

TITLE CCGA TRAY BOX CARRIER
CARTON

SCALE 1:2	SIZE A	DRAWING NO. 900001	REV A
--------------	-----------	-----------------------	----------

DO NOT SCALE DRAWING

SHEET 13 OF 13