

# EXPLODED VIEW CCGA TRAY BOX SYSTEM 1.0MM PITCH

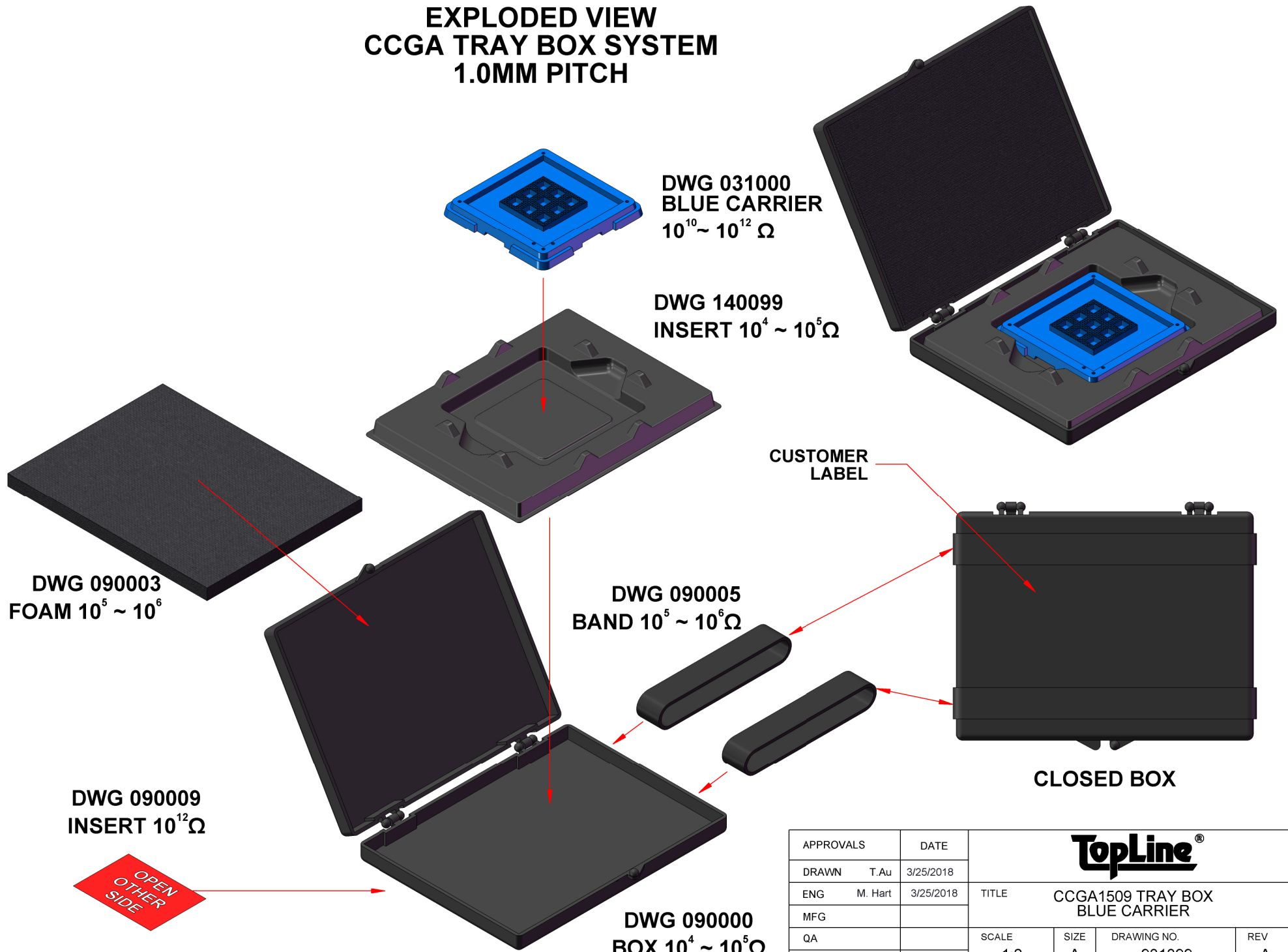

APPROVALS	DATE	<b>TopLine®</b>		
DRAWN T. Au	3/25/2018			
ENG M. Hart	3/25/2018	TITLE CCGA1509 TRAY BOX BLUE CARRIER		
MFG		SCALE	SIZE	DRAWING NO.
QA		1:2	A	931399
CUST				REV A
REVISED		DO NOT SCALE DRAWING		SHEET 1 OF 10

MODEL  
TOP

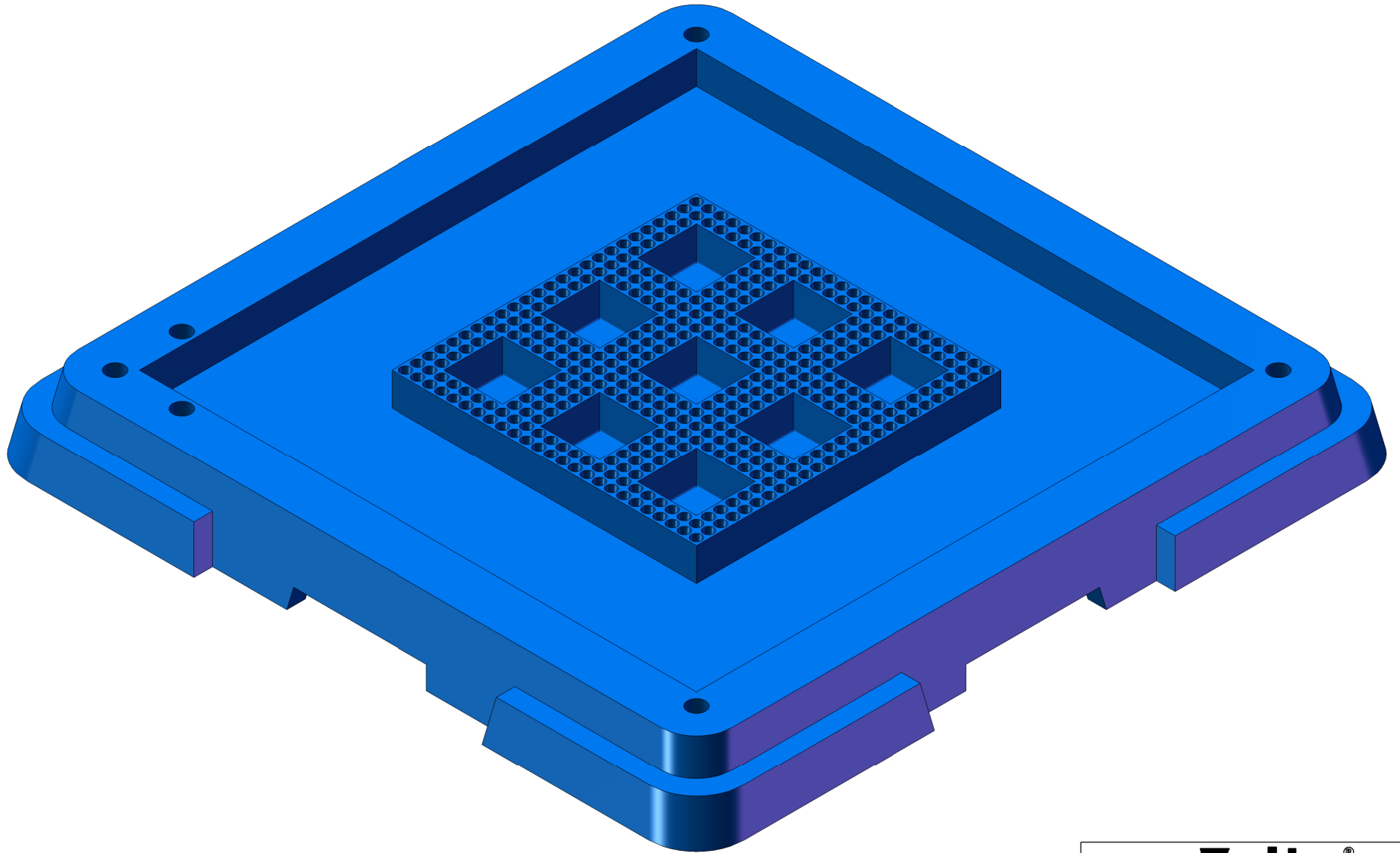

**TopLine**<sup>®</sup>

TITLE CCGA1509 TRAY BOX  
BLUE CARRIER

SCALE 3:1	SIZE A	DRAWING NO. 931399	REV
--------------	-----------	-----------------------	-----

DO NOT SCALE DRAWING SHEET 2 OF 10

**TOP**

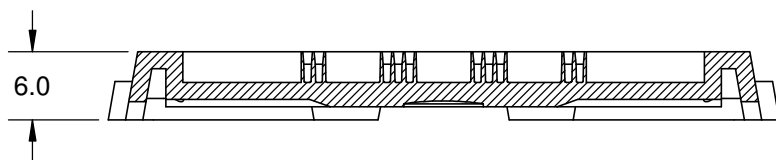
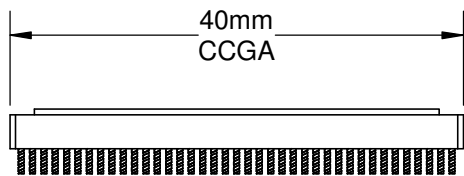
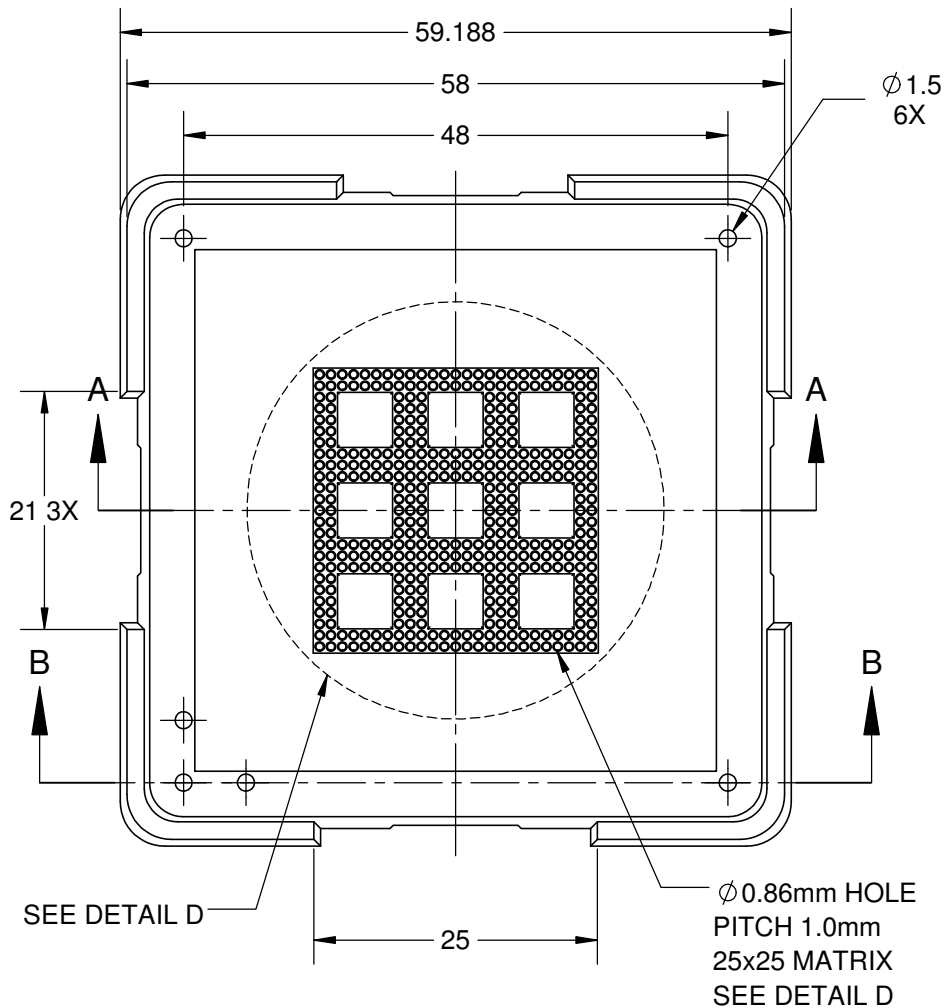

**SECTION A-A**

**SIDE**

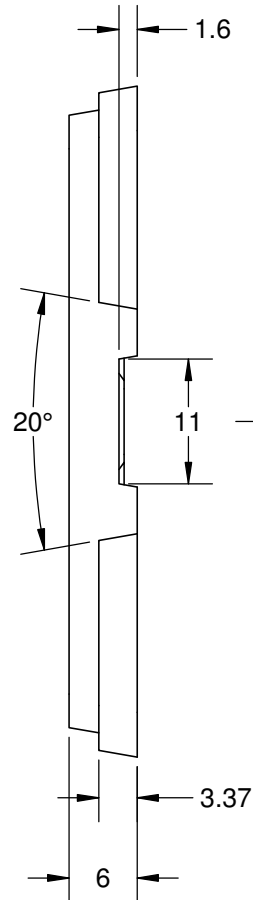

**BOTTOM**

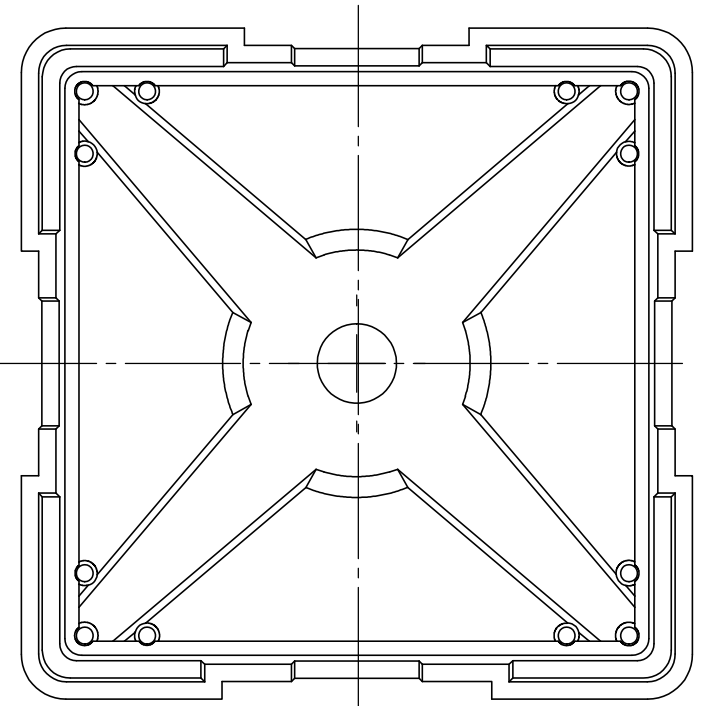

**NOTES:**

1. DIMENSION MM.
2. MATERIAL: BLUE ABS PERMASTAT® 600.
3. TEMPERATURE 60° MAX.
4. MASS 10.3 GRAMS.
5. PERMANENT ESD ANTI-STATIC
6. SURFACE RESISTIVITY  $10^{10} \sim 10^{12} \Omega$

**TopLine®**

TITLE			
CCGA1509-1517 TRAY BOX BLUE CARRIER			
SCALE	SIZE	DRAWING NO.	REV
3:2	A	931399	
DO NOT SCALE DRAWING			SHEET 3 OF 10

# DETAIL D

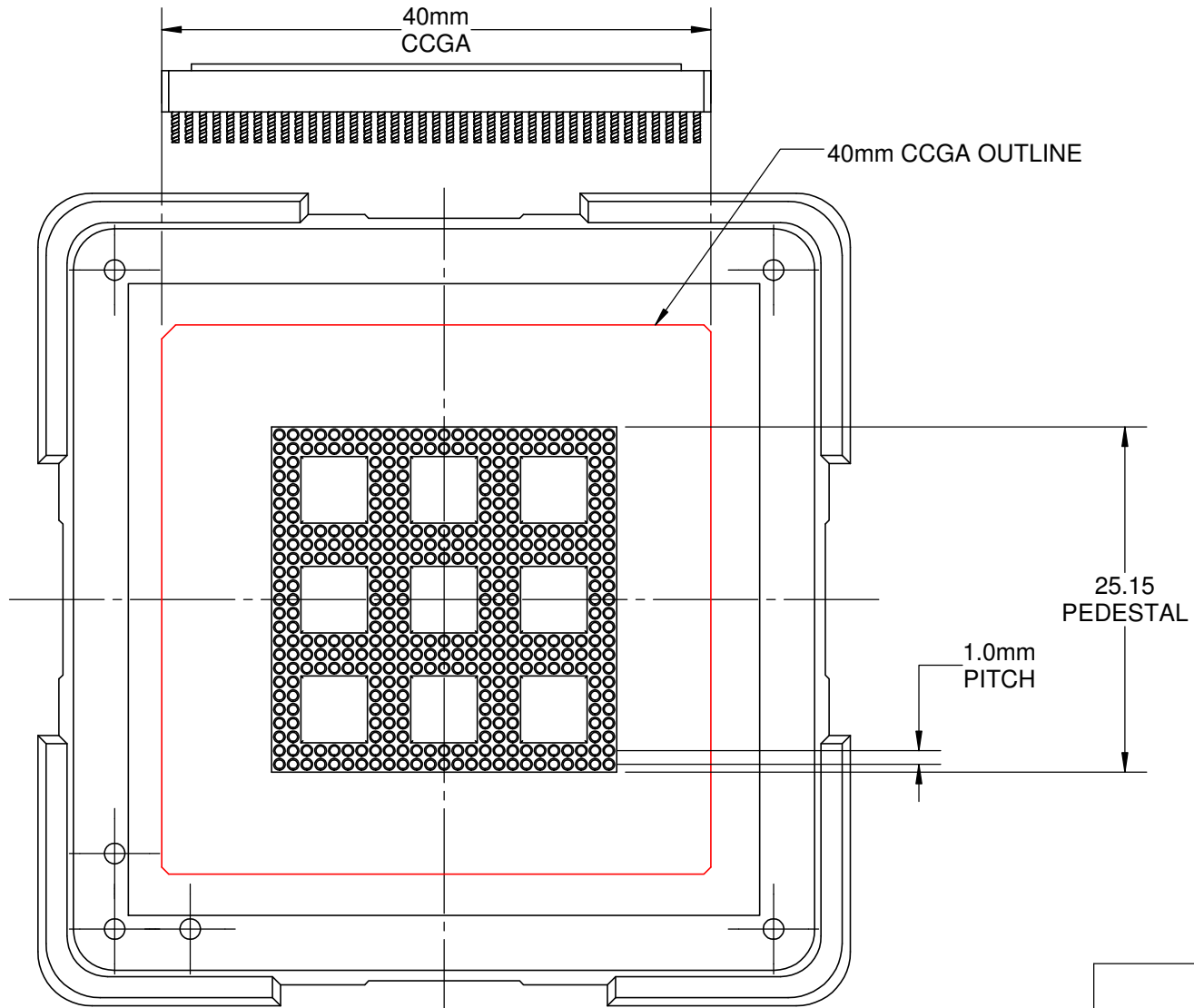

- NOTES:  
 1. DIMENSIONS MM.  
 2. NOT TO SCALE

<b>TopLine®</b>			
TITLE		CCGA1509 TRAY BOX BLUE CARRIER	
SCALE	SIZE	DRAWING NO.	REV
2:1	A	931399	
DO NOT SCALE DRAWING			SHEET 4 OF 10

**TOP (OPEN)**

**SIDE VIEW (OPEN)**

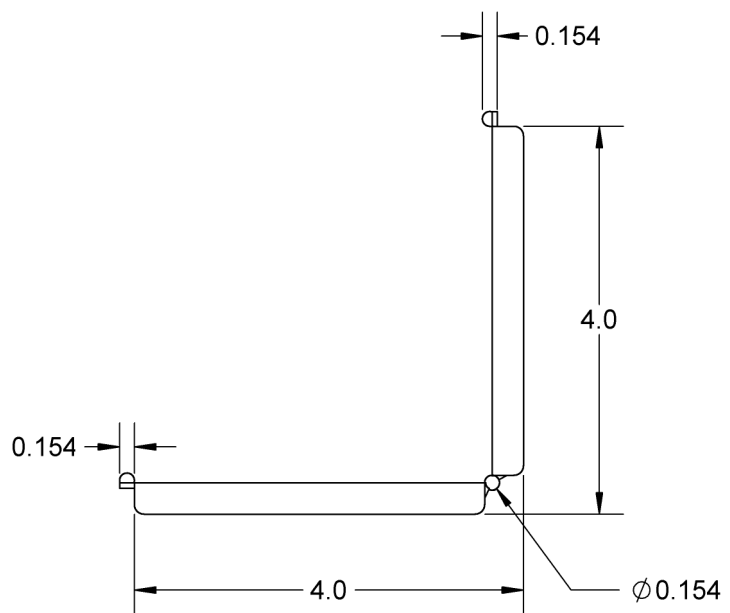
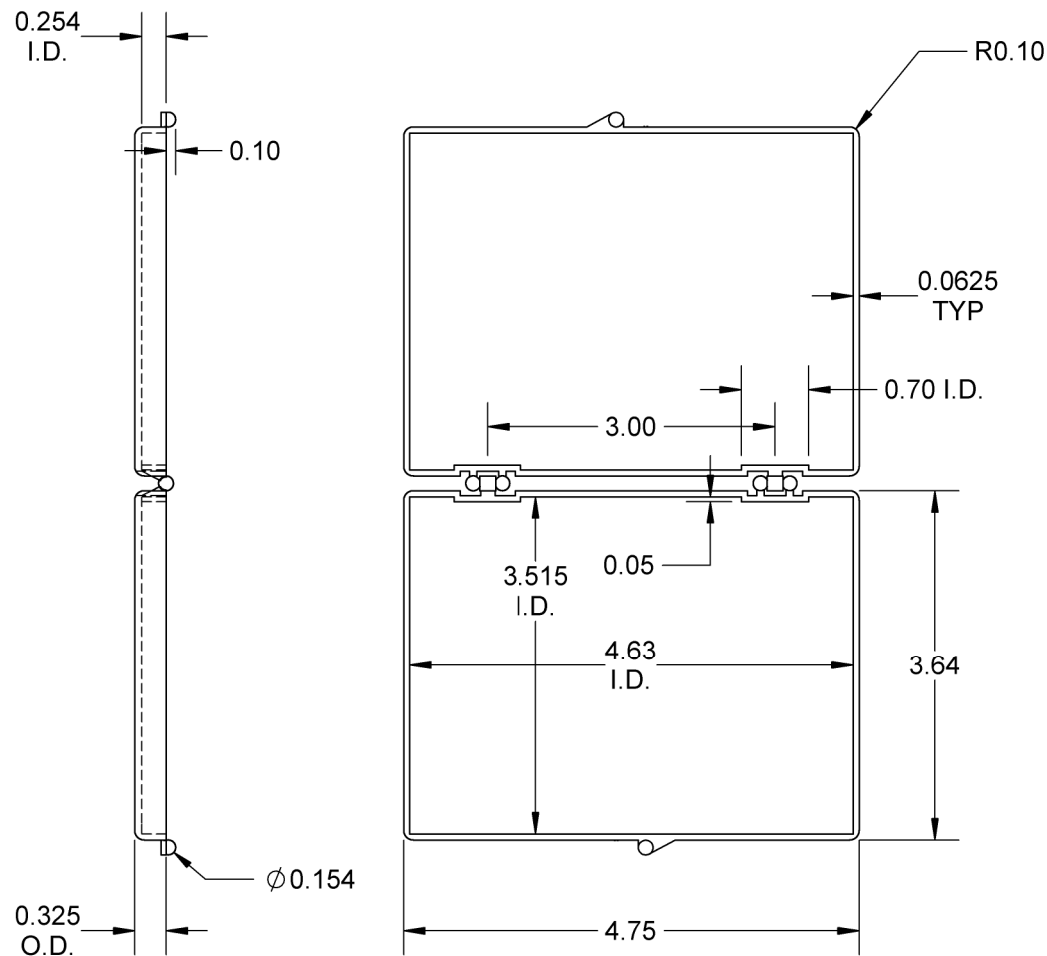

**MODEL**

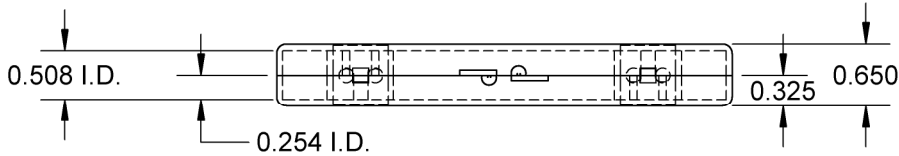

**FRONT (CLOSED)**

- Notes: (Unless Otherwise Specified).
- 1) SURFACE RESISTIVITY:  $10^4 \sim 10^5 \Omega$ .
  - 2) MATERIAL: CARBON FILLED POLYPROPYLENE.
  - 3) DIMENSIONS IN INCHES.

<b>TopLine®</b>			
TITLE		EC1 (EMPTY BOX) HINGE BOX	
SCALE	SIZE	DRAWING NO.	REV
1:2	A	090000	A
DO NOT SCALE DRAWING			SHEET 5 OF 10

**TOP VIEW**

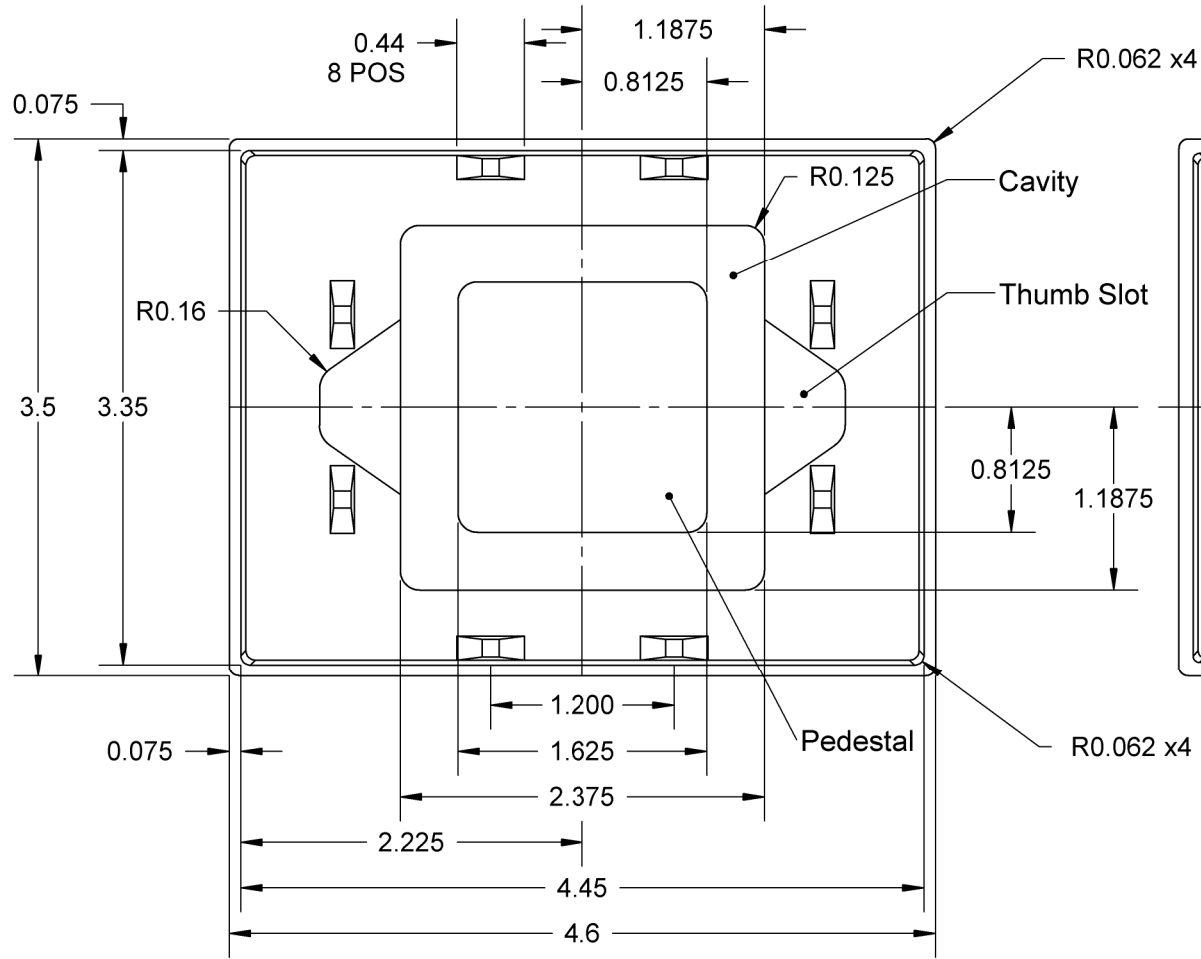

**BOTTOM VIEW**

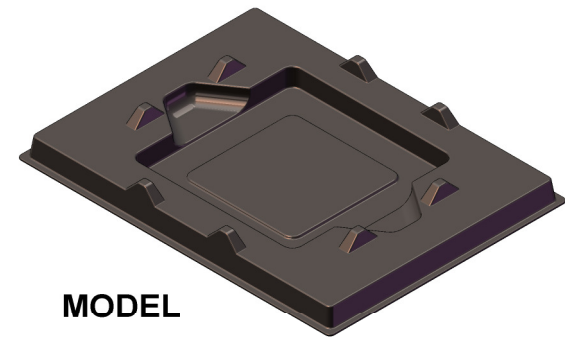
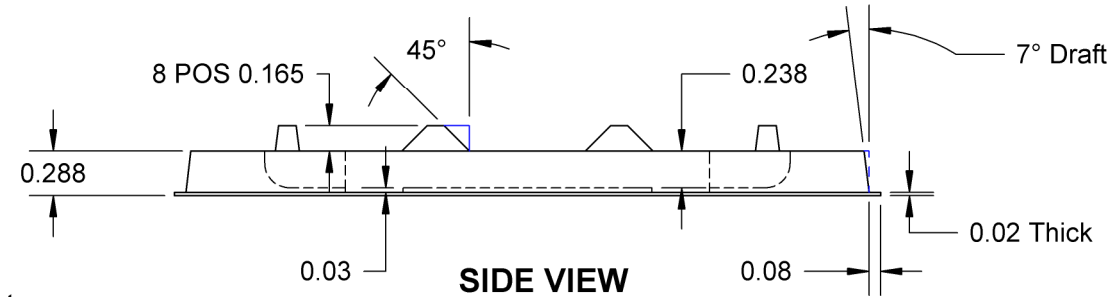
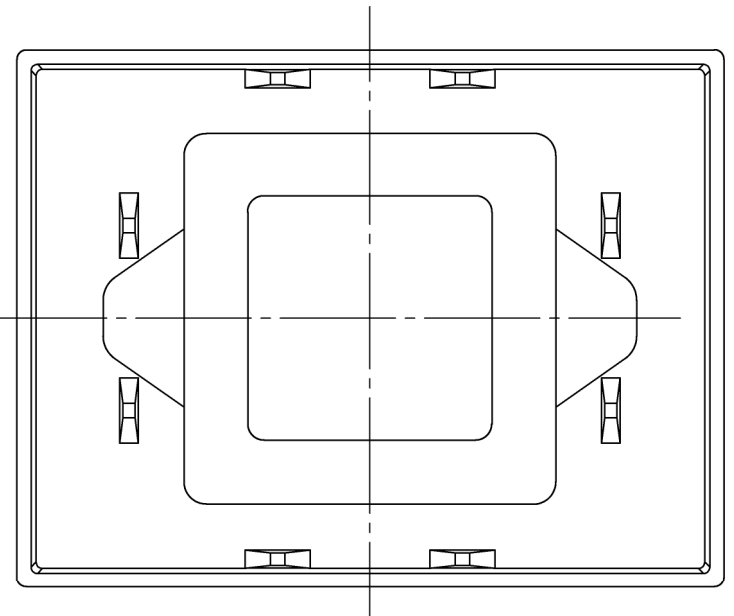

**MODEL**

- Notes:**  
 1. DIMENSIONS INCH  
 2. SURFACE RESISTIVITY  $10^4 \sim 10^5 \Omega$

<b>TopLine®</b>			
TITLE CCGA TRAY INSERT FOR 4.625 x 3.5 HINGE BOX			
SCALE	SIZE	DRAWING NO.	REV
2:2.5	A	140099	A
DO NOT SCALE DRAWING			SHEET 6 OF 10

### TOP

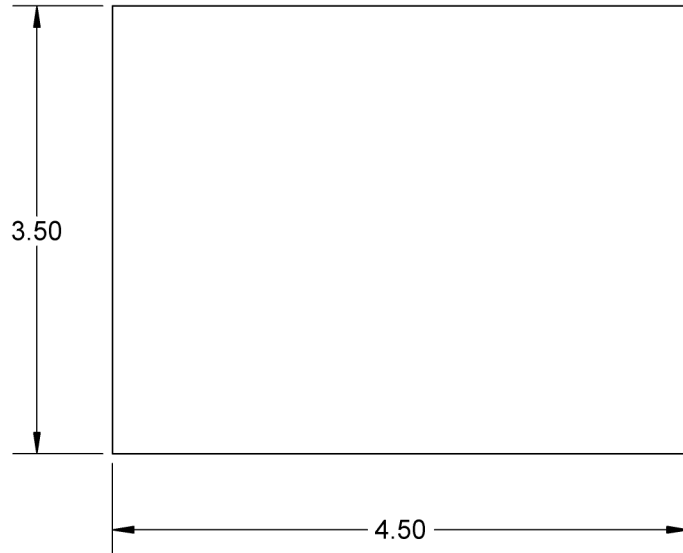

### EDGE

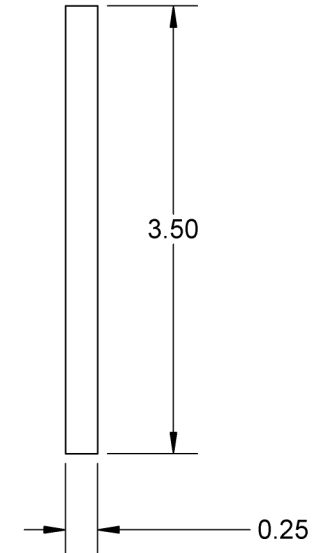

### SIDE

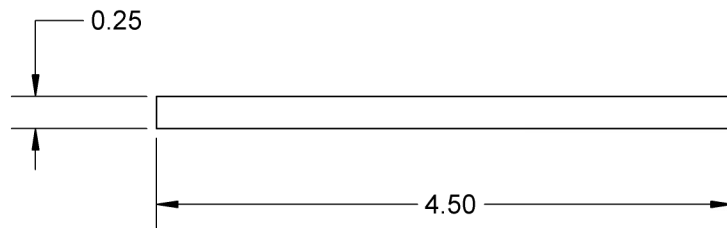

**MODEL**

Notes: (Unless Otherwise Specified).

- 1) SURFACE RESISTIVITY:  $10^5\Omega$  TO  $10^6\Omega$
- 3) DENSITY 1.7 PFC Min.
- 4) DIMENSIONS IN INCHES.

**TopLine**<sup>®</sup>

TITLE EC1-FOAM-SOFT-.25-A  
LOW DENSITY FOAM

SCALE 1:1.5	SIZE A	DRAWING NO. 090003	REV A
----------------	-----------	-----------------------	----------

DO NOT SCALE DRAWING

SHEET 7 OF 10

### TOP

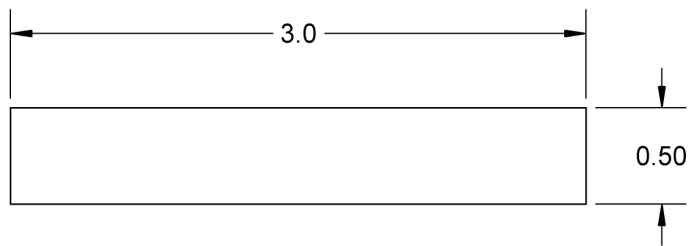

### EDGE

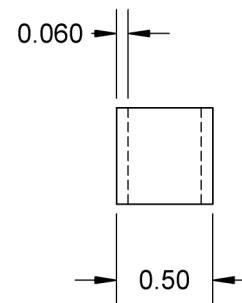

### SIDE

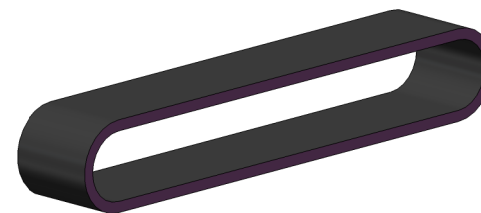
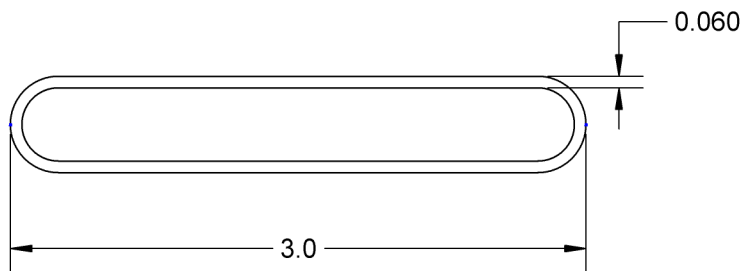

### MODEL

Notes: (Unless Otherwise Specified).

- 1) SURFACE RESISTIVITY:  $10^5 \sim 10^6$ .
- 2) DIMENSIONS IN INCHES (RESTING POSITION).

<b>TopLine<sup>®</sup></b>			
TITLE		RUBBER BAND-3.0-C BLACK CONDUCTIVE	
SCALE	SIZE	DRAWING NO.	REV
1:1	A	090005	A
DO NOT SCALE DRAWING			SHEET 8 OF 10



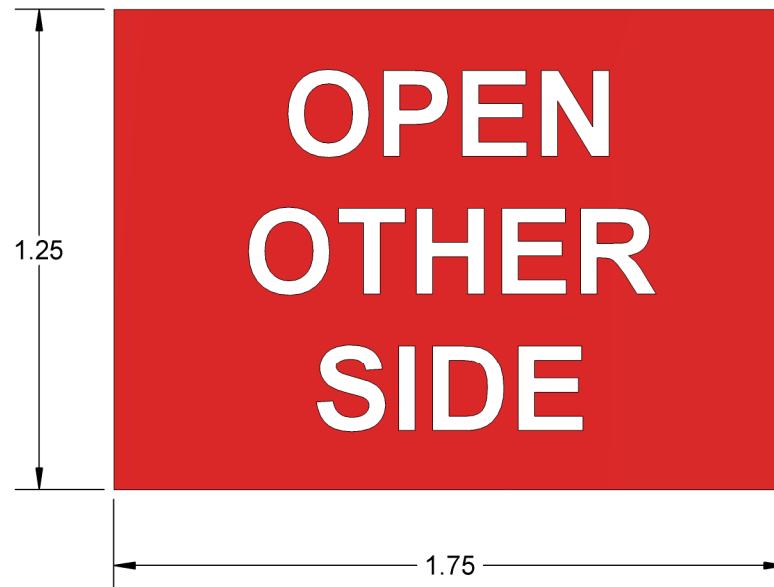

Notes: (Unless Otherwise Specified).

1. DIMENSIONS INCHES.
2. MATERIAL: PAPER LABEL WITH ADHESIVE.
3. COLOR: RED.
4. PURPOSE: IDENTIFY BOTTOM OF HINGE BOX.

<b>TopLine<sup>®</sup></b>			
TITLE		LABEL FOR BOTTOM OF HINGE BOX	
SCALE	SIZE	DRAWING NO.	REV
2:1	A	090009	A
DO NOT SCALE DRAWING			SHEET 9 OF 10

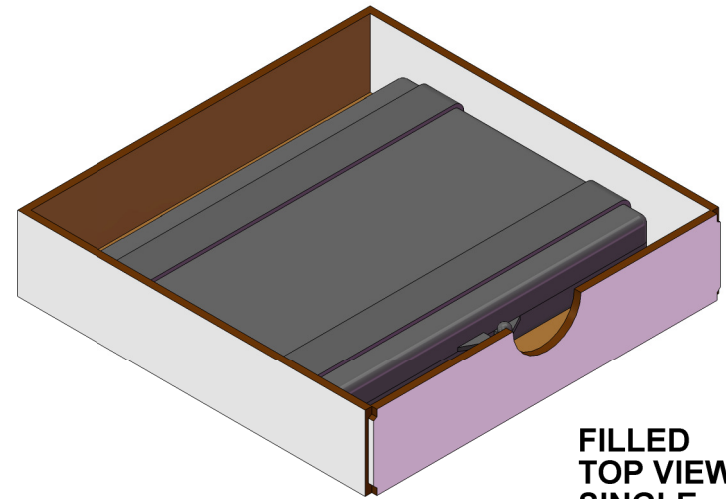
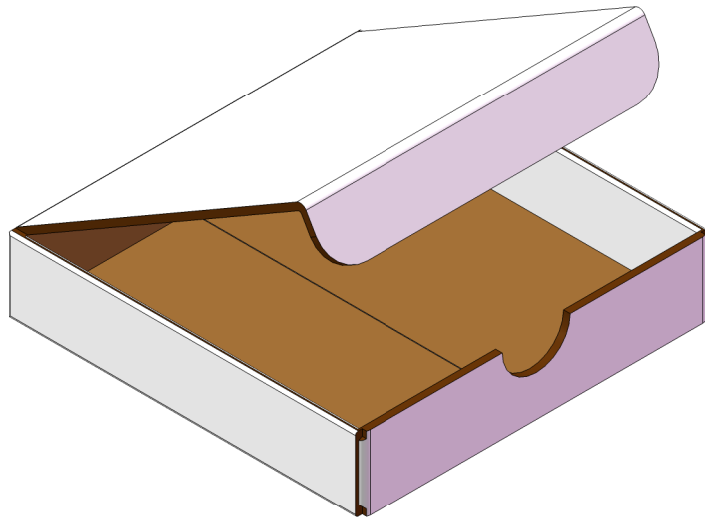
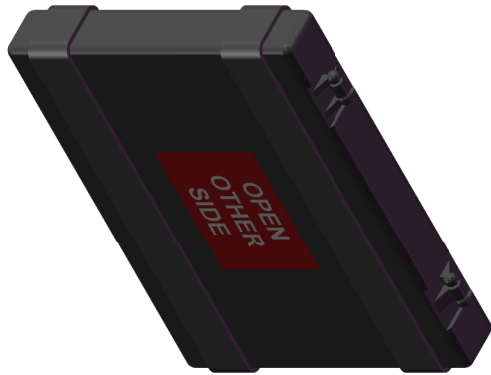

FILLED  
TOP VIEW  
SINGLE

NOTES: (Unless Otherwise Specified).

1. DIMENSIONS INCHES.
2. MEASUREMENT INCLUDES RUBBER BANDS.
3. BOX SIZE SUBJECT TO CHANGE.

**TopLine**<sup>®</sup>

TITLE CCGA TRAY BOX CARRIER  
CARTON

SCALE 1:2	SIZE A	DRAWING NO. 900001	REV A
--------------	-----------	-----------------------	----------

DO NOT SCALE DRAWING

SHEET 10 OF 10