

# EXPLODED VIEW CCGA TRAY BOX SYSTEM 1.27mm PITCH

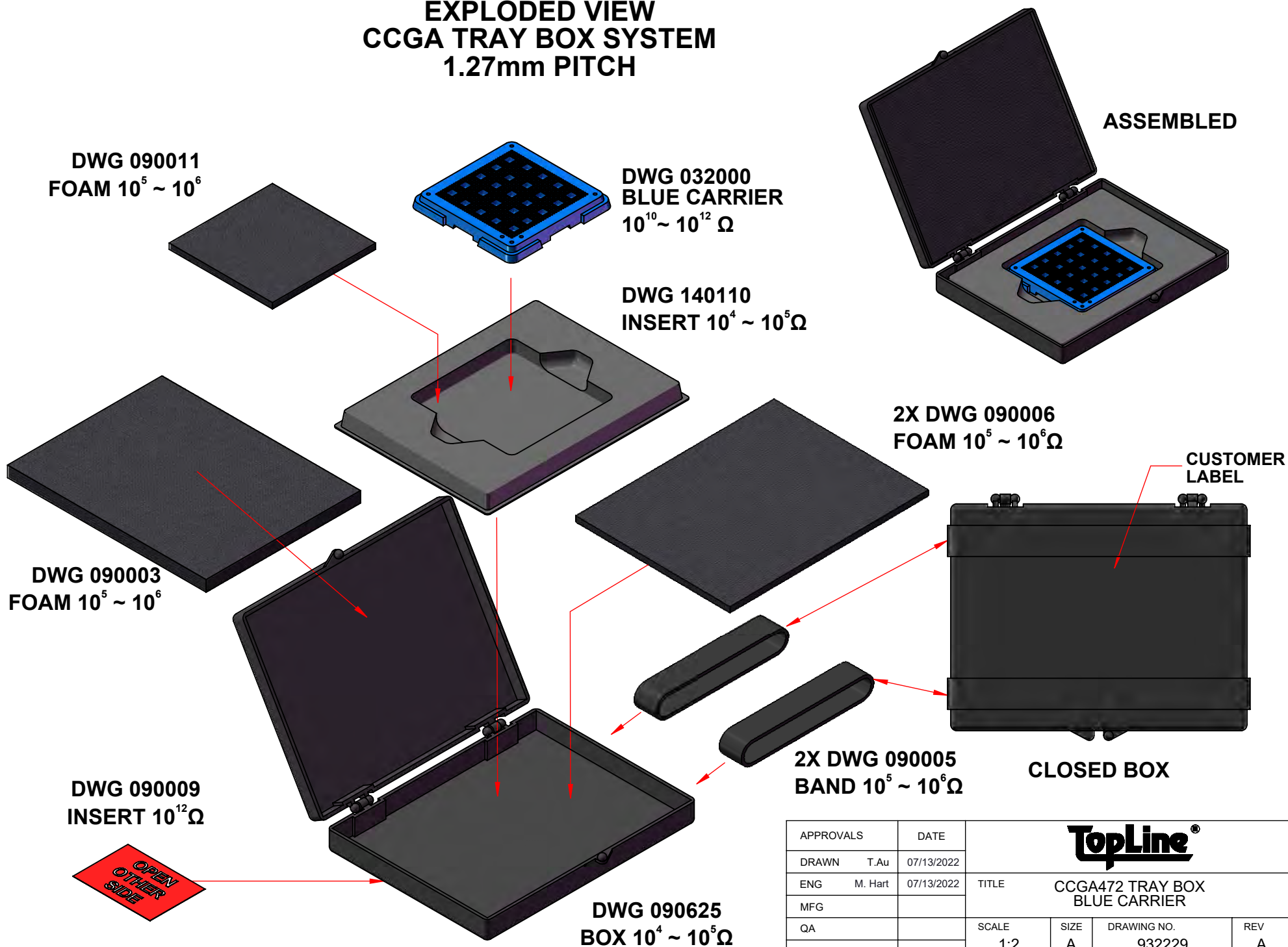

APPROVALS	DATE	<b>TopLine®</b>		
DRAWN T. Au	07/13/2022			
ENG M. Hart	07/13/2022	TITLE CCGA472 TRAY BOX BLUE CARRIER		
MFG		SCALE	SIZE	DRAWING NO.
QA		1:2	A	932229
CUST				REV A
REVISED		DO NOT SCALE DRAWING		SHEET 1 OF 11

MODEL  
TOP

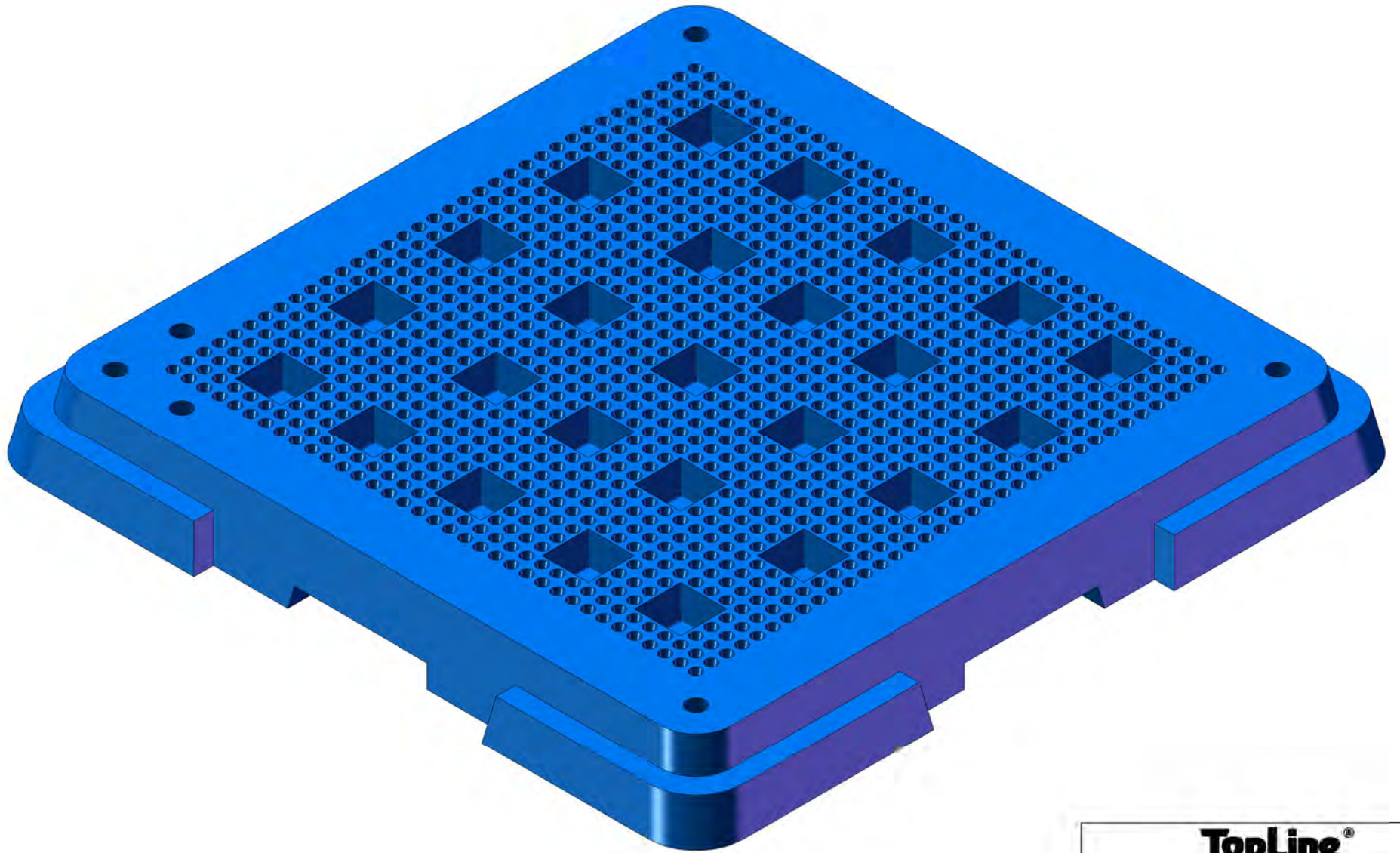

<b>TopLine<sup>®</sup></b>			
TITLE		CCGA472 TRAY BOX BLUE CARRIER	
SCALE	SIZE	DRAWING NO.	REV
3:1	A	932229	A
DO NOT SCALE DRAWING			SHEET 2 OF 10

**TOP**

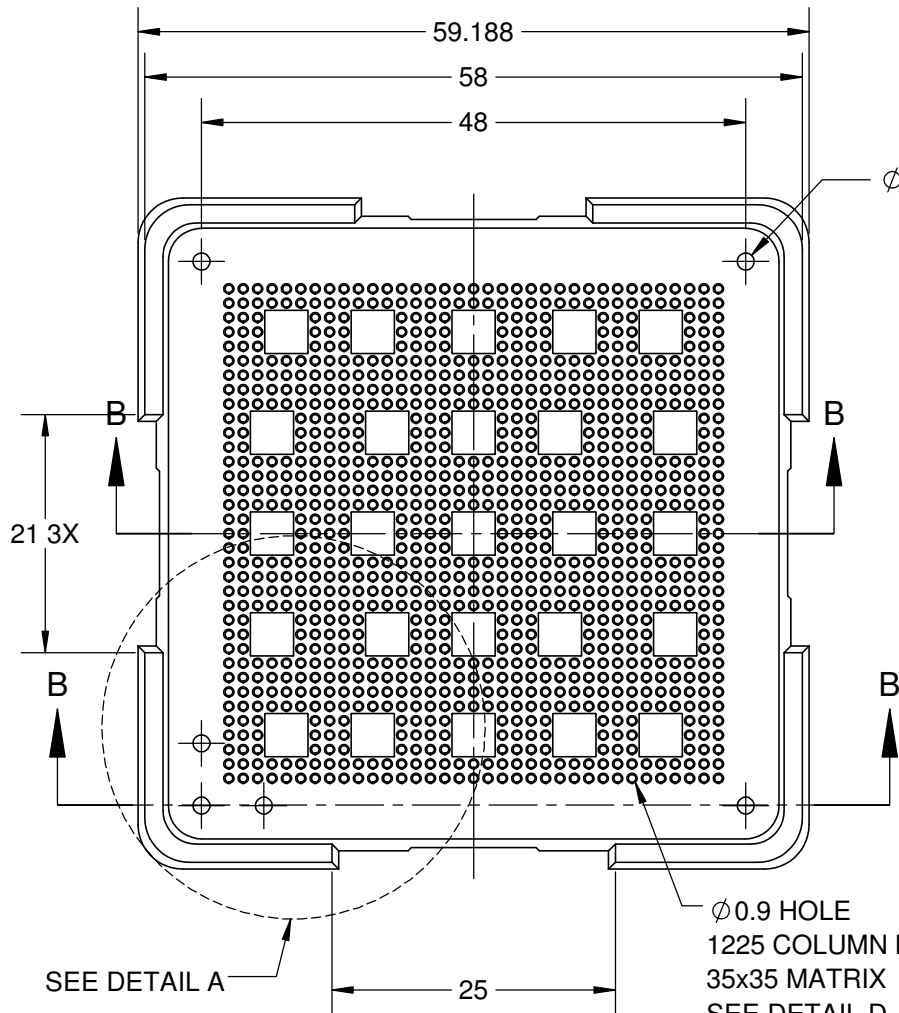

**SIDE**

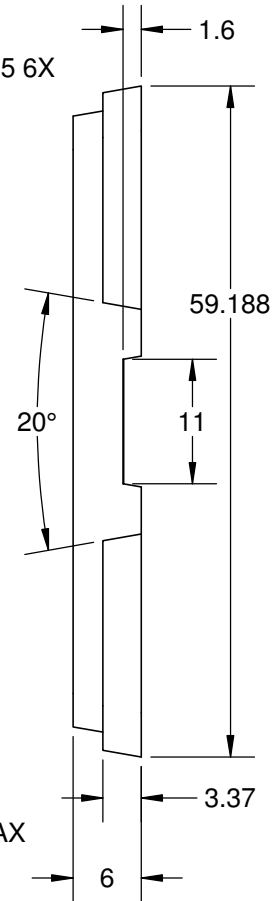

**BOTTOM**

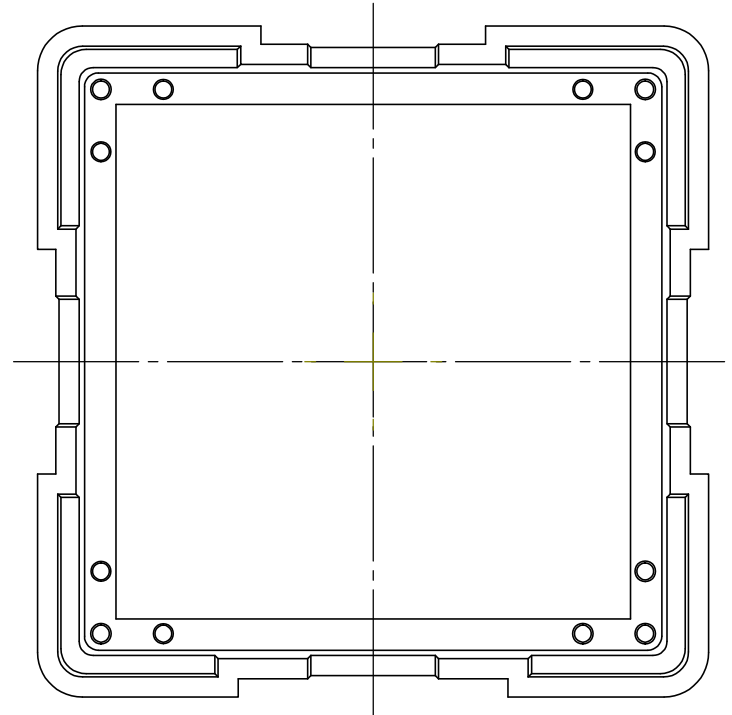

Ø1.56X

Ø0.9 HOLE  
1225 COLUMN MAX  
35x35 MATRIX  
SEE DETAIL D

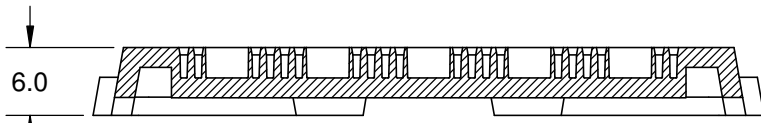
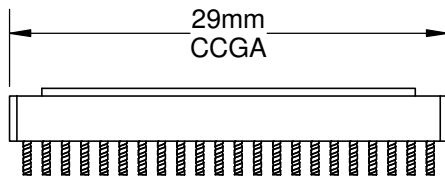

**SECTION B-B**

- NOTES:**
1. DIMENSION MM.
  2. MATERIAL: BLUE ABS PERMASTAT® 600
  3. TEMPERATURE 60° MAX.
  4. MASS 15.1 GRAMS.
  5. PERMANENT ESD ANTI-STATIC
  6. SURFACE RESISTIVITY  $10^{10} \sim 10^{12} \Omega$

<b>TopLine®</b>			
TITLE		CCGA472 TRAY BOX BLUE CARRIER	
SCALE	SIZE	DRAWING NO.	REV
3:2	A	932229	A
DO NOT SCALE DRAWING			SHEET 3 OF 10

# DETAIL D

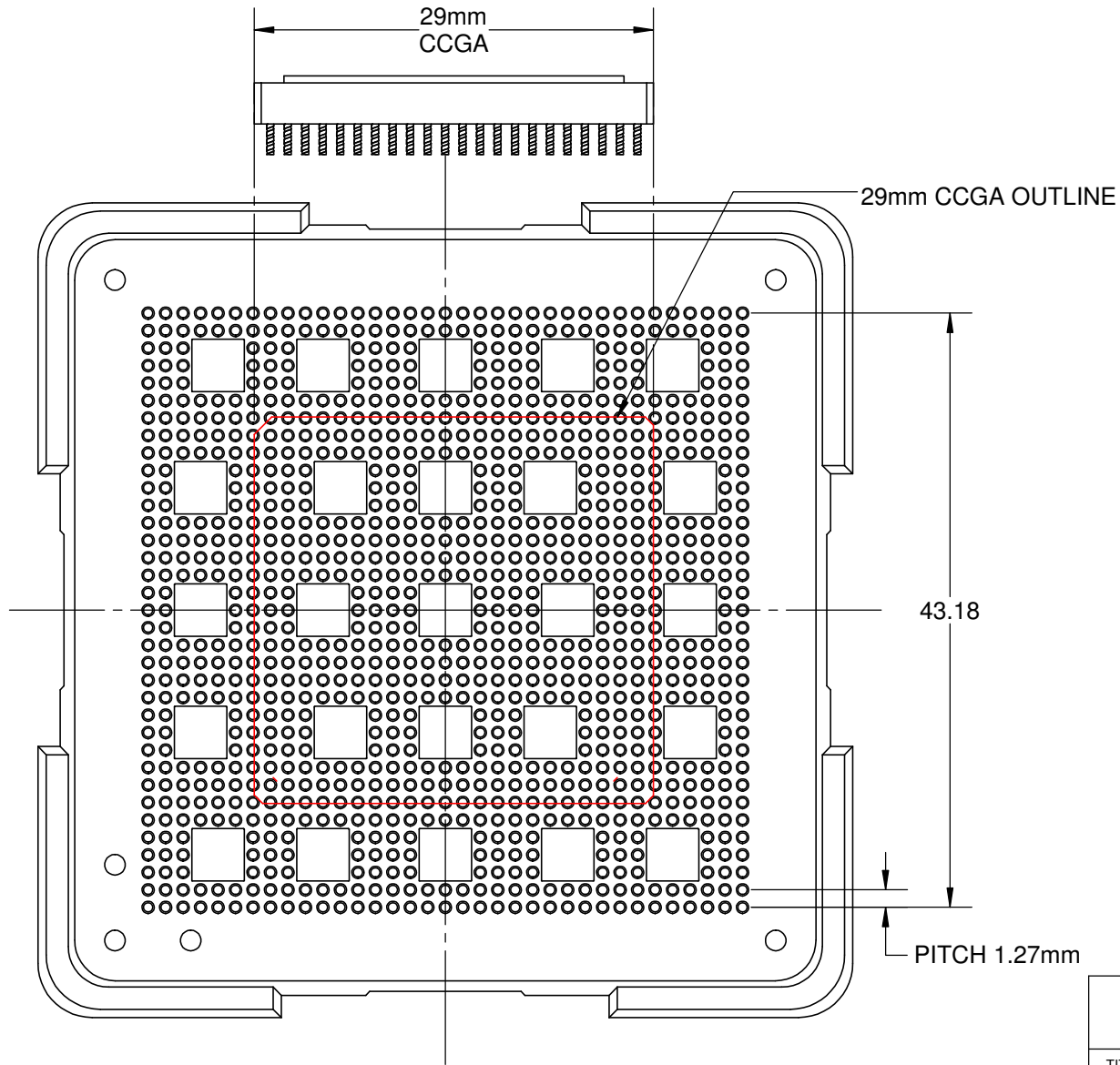

- NOTES:  
 1. DIMENSIONS MM.  
 2. NOT TO SCALE

<b>TopLine®</b>			
TITLE		CCGA472 TRAY BOX BLUE CARRIER	
SCALE	SIZE	DRAWING NO.	REV
2:1	A	932229	A
DO NOT SCALE DRAWING			SHEET 4 OF 10

### TOP (OPEN)

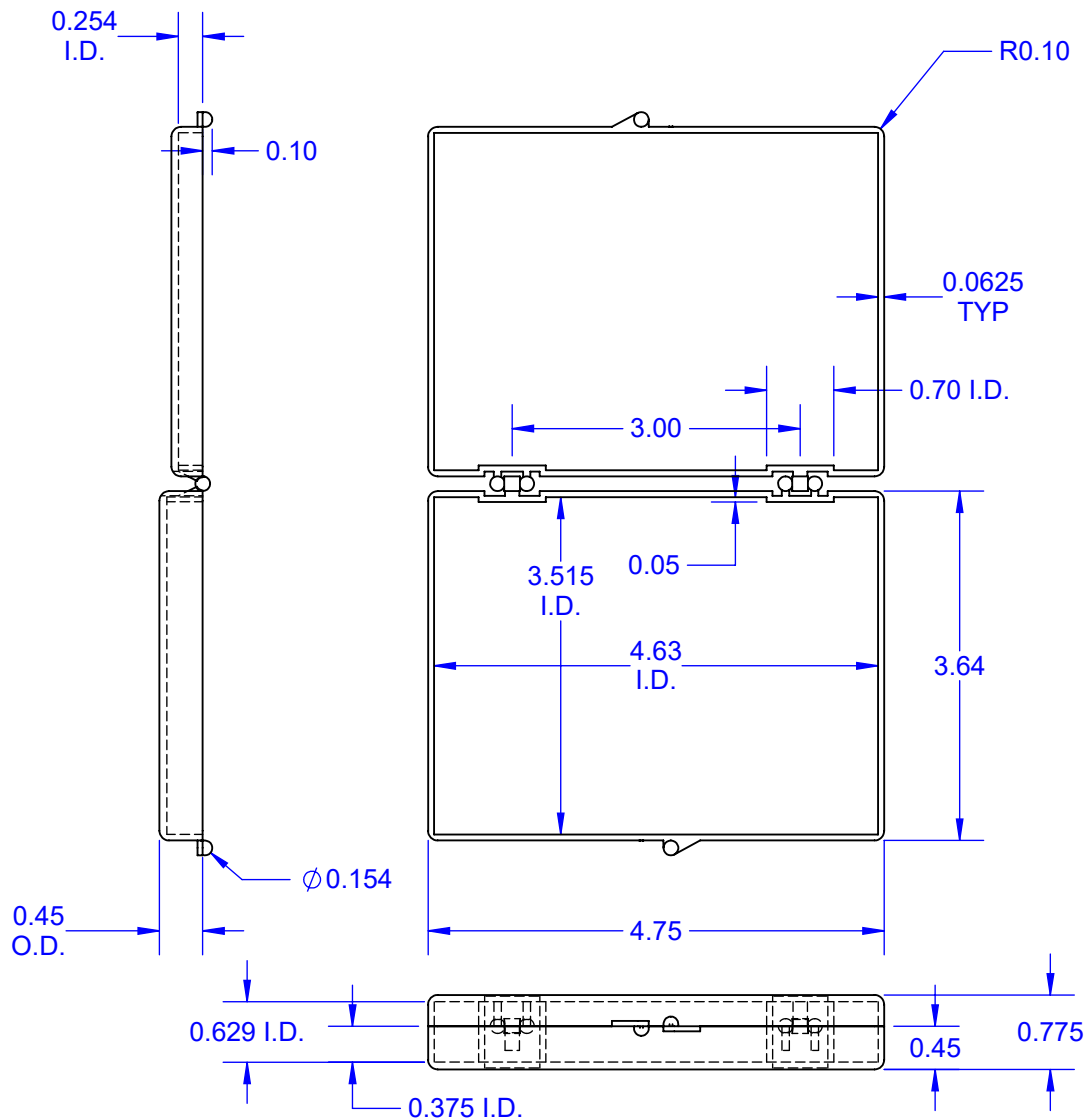

### FRONT (CLOSED)

### SIDE VIEW (OPEN)

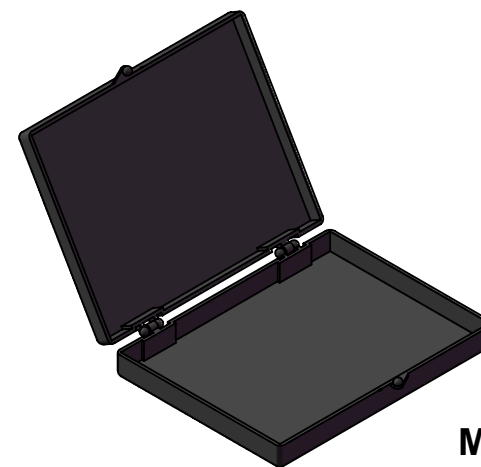
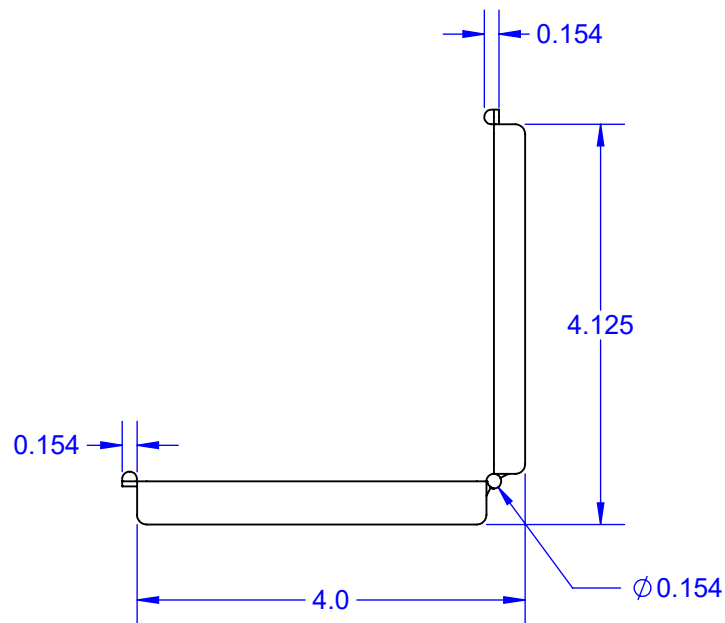

**MODEL**

Notes: (Unless Otherwise Specified).

- 1) SURFACE RESISTIVITY:  $10^3 \Omega$  TO  $10^6 \Omega$  PER SQUARE.
- 2) MATERIAL: CARBON FILLED POLYPROPYLENE.
- 3) DIMENSIONS IN INCHES.

APPROVALS	DATE	<b>TopLine®</b>			
DRAWN T. Au	07/13/2022				
ENG M. Hart	07/13/2022	TITLE EC1-15mm EMPTY HINGE BOX			
MFG		SCALE	SIZE	DRAWING NO.	REV
QA		1:2	A	090625	A
CUST		DO NOT SCALE DRAWING			SHEET 5 OF 11
REVISED					

### TOP VIEW

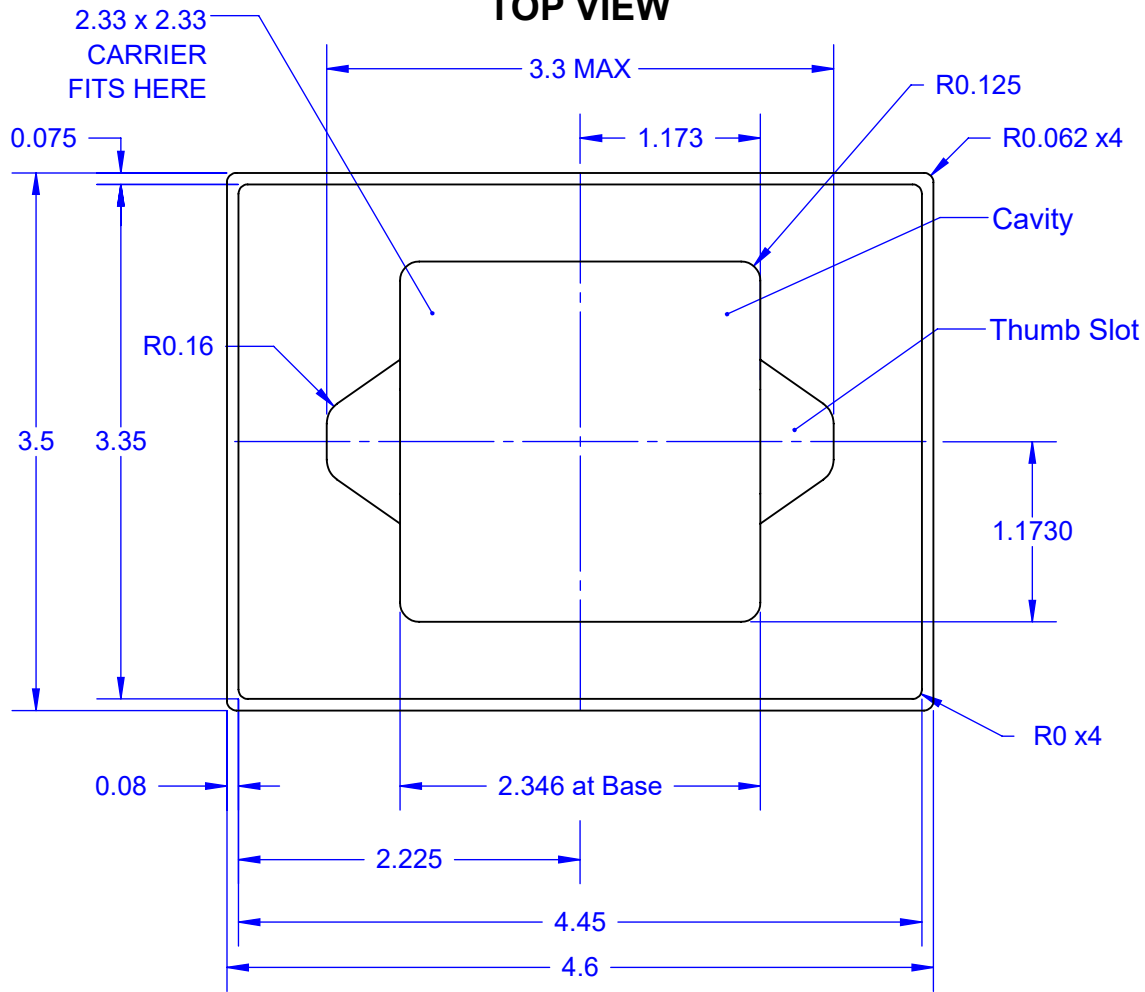

### BOTTOM VIEW

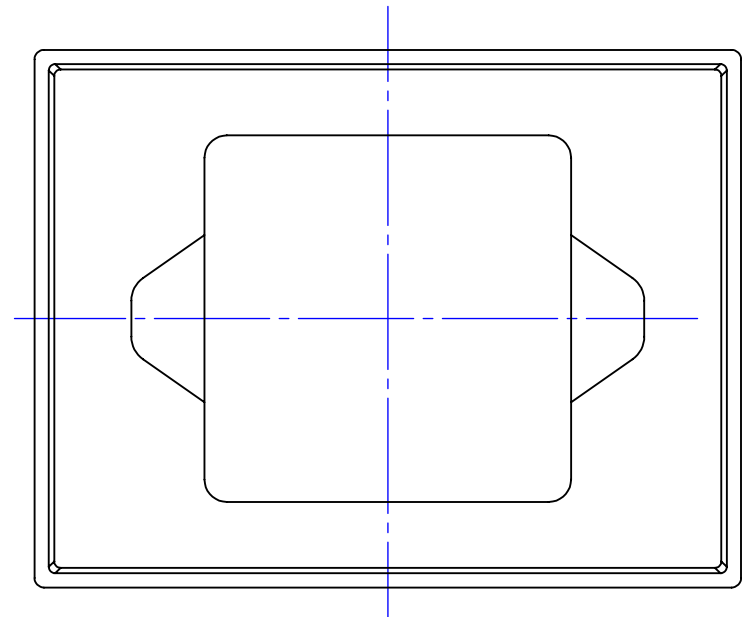

### SIDE VIEW

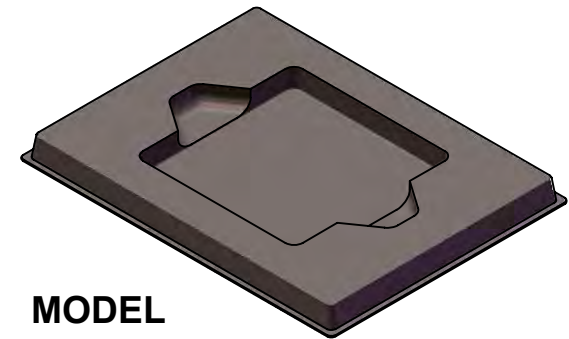
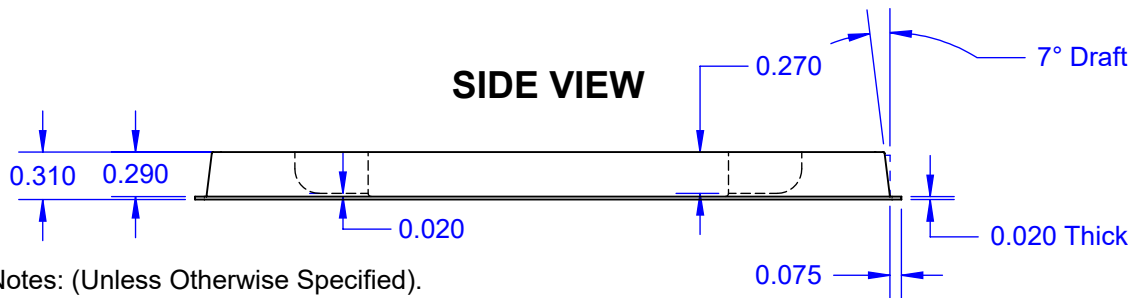

MODEL

Notes: (Unless Otherwise Specified).

- 1) DIMENSIONS: INCHES.
- 2) MATERIAL: CONDUCTIVE STYRENE.
- 3) SURFACE RESISTIVITY <math>< 10^4 \Omega</math>.

**TopLine®**

TITLE CCGA TRAY INSERT  
FOR 4.625 x 3.5 HINGE BOX

SCALE	SIZE	DRAWING NO.	REV
2:2.5	A	140110	A

DO NOT SCALE DRAWING

SHEET 6 OF 11

**TOP**

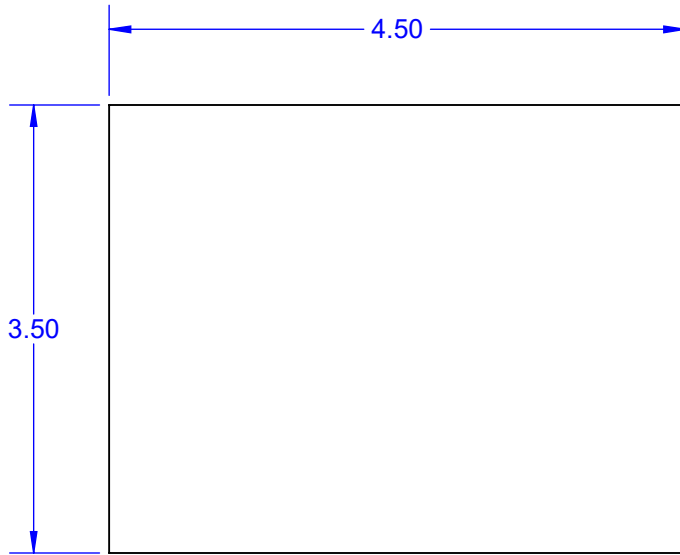

**EDGE**

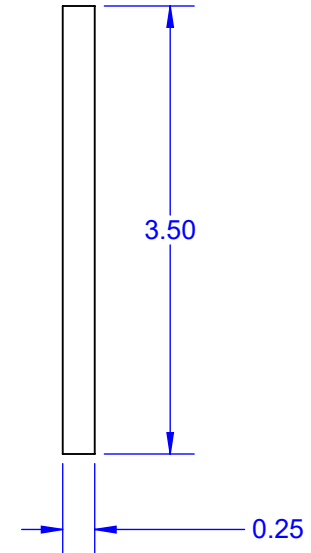

**SIDE**

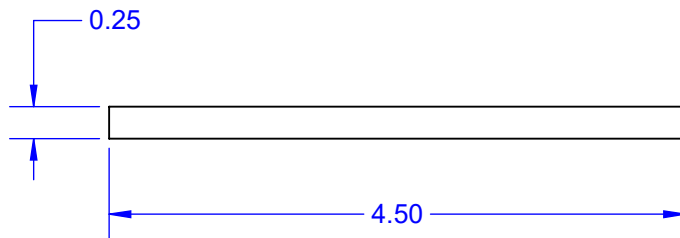

- Notes: (Unless Otherwise Specified).  
1) SURFACE RESISTIVITY:  $10^5\Omega$  TO  $10^6\Omega$ .  
3) DENSITY 1.7 PFC Min.  
4) DIMENSIONS IN INCHES

<b>TopLine®</b>			
TITLE		EC1-FOAM-SOFT-.25-A LOW DENSITY FOAM	
SCALE	SIZE	DRAWING NO.	REV
1:1.5	A	090003	A
DO NOT SCALE DRAWING			SHEET 7 OF 11

**TOP**

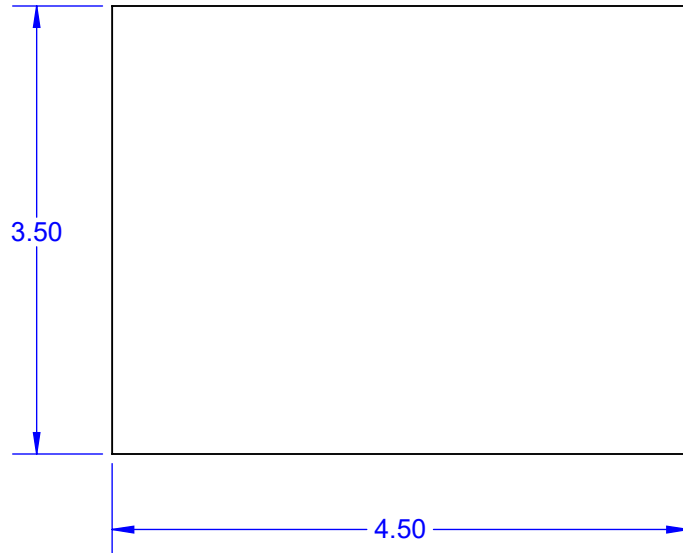

**EDGE**

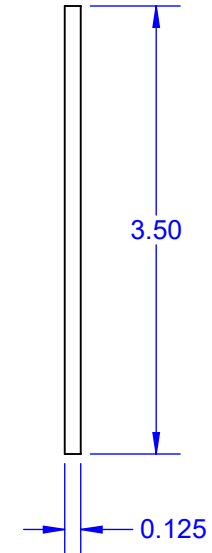

**SIDE**

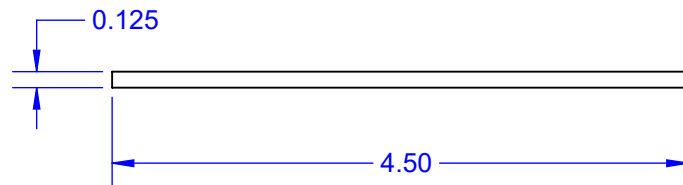

**MODEL**

- Notes: (Unless Otherwise Specified).  
1) SURFACE RESISTIVITY:  $10^5 \sim 10^6 \Omega$   
3) DENSITY 1.7 PFC Min.  
4) DIMENSIONS IN INCHES.

<b>TopLine®</b>			
TITLE    EC1-FOAM-SOFT-.125-A LOW DENSITY FOAM			
SCALE 1:1.5	SIZE A	DRAWING NO. 090006	REV A
DO NOT SCALE DRAWING			SHEET 8 OF 11



**TOP**

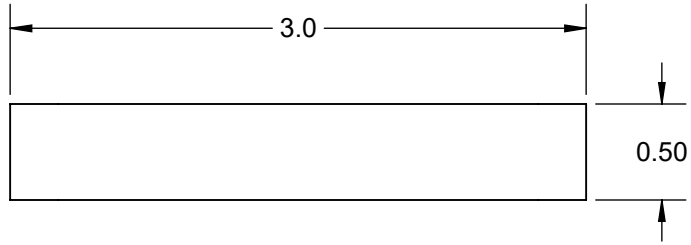

**EDGE**

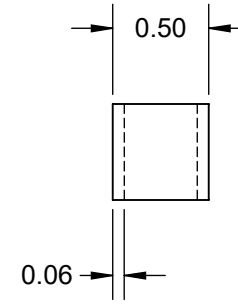

**SIDE**

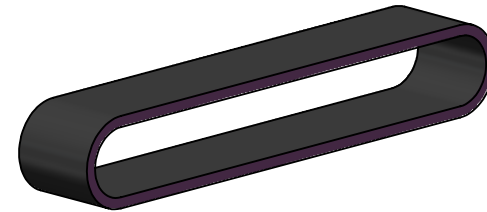
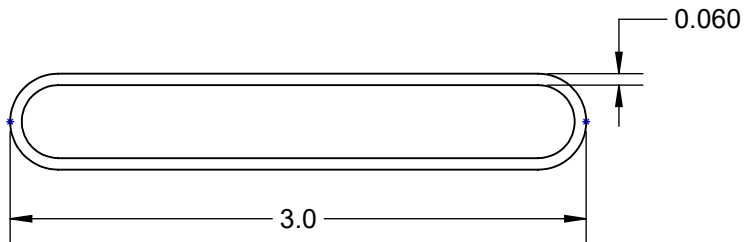

**MODEL**

Notes: (Unless Otherwise Specified).

1) SURFACE RESISTIVITY:  $10^3 \Omega$  TO  $10^6 \Omega$ .

2) DIMENSIONS in INCHES (RESTING POSITION).

<b>TopLine®</b>			
TITLE		RUBBER BAND-3.0-C BLACK CONDUCTIVE	
SCALE	SIZE	DRAWING NO.	REV
1:1	A	090005	A
DO NOT SCALE DRAWING			SHEET 9 OF 11

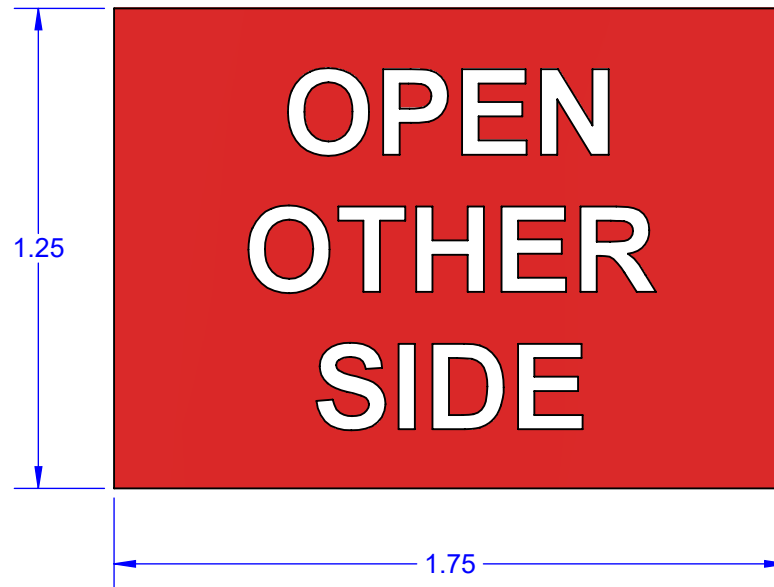

Notes: (Unless Otherwise Specified).

1. DIMENSIONS IN INCHES.
2. MATERIAL: PAPER LABEL WITH ADHESIVE.
3. COLOR: RED.
4. PURPOSE: IDENTIFY BOTTOM OF HINGE BOX.

<b>TopLine®</b>			
TITLE		LABEL FOR BOTTOM OF HINGE BOX	
SCALE	SIZE	DRAWING NO.	REV
2:1	A	090009	A
DO NOT SCALE DRAWING			SHEET 10 OF 11

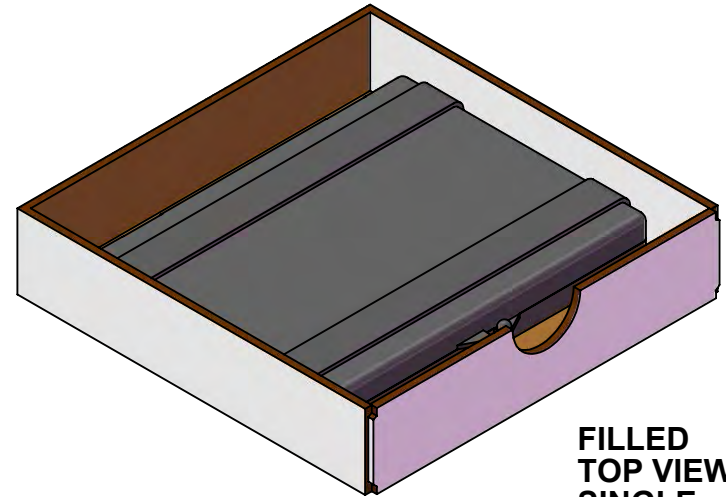
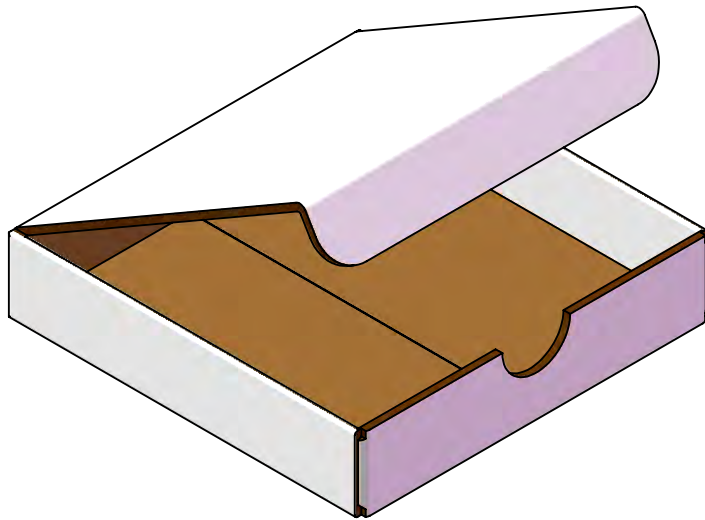
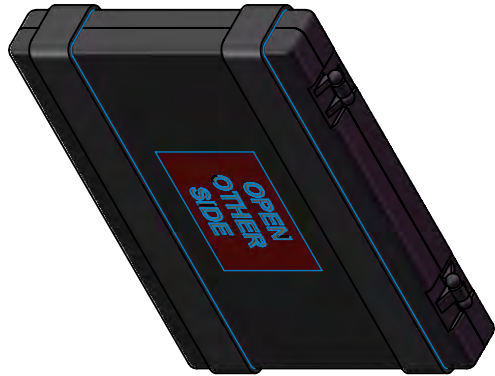

**FILLED  
TOP VIEW  
SINGLE**

NOTES: (Unless Otherwise Specified).

1. DIMENSIONS INCHES.
2. MEASUREMENT INCLUDES RUBBER BANDS.
3. BOX SIZE SUBJECT TO CHANGE.

**TopLine®**

TITLE CCGA TRAY BOX CARRIER  
CARTON

SCALE 1:2	SIZE A	DRAWING NO. 900001	REV A
--------------	-----------	-----------------------	----------

DO NOT SCALE DRAWING

SHEET 11 OF 11