

TOP VIEW

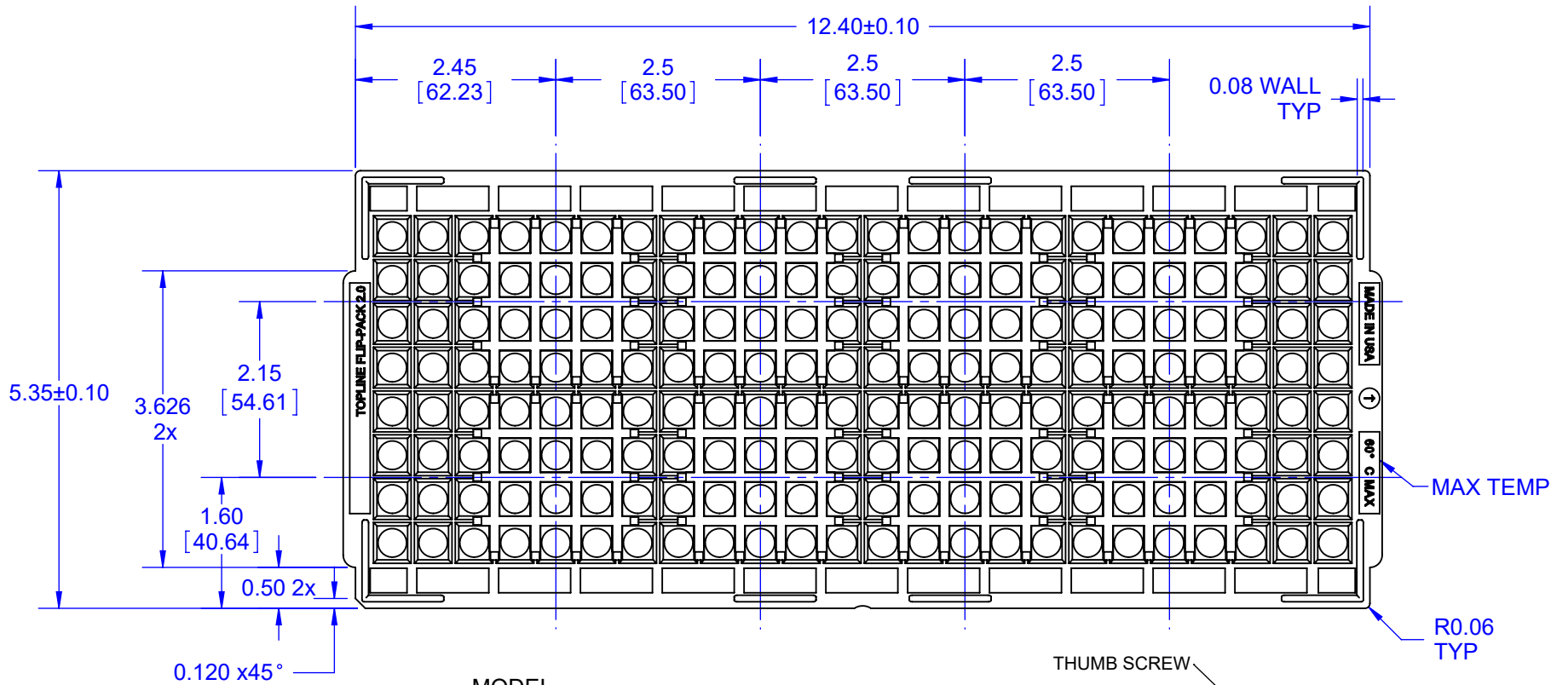

MODEL
FLIP PACK 2.0
REV B

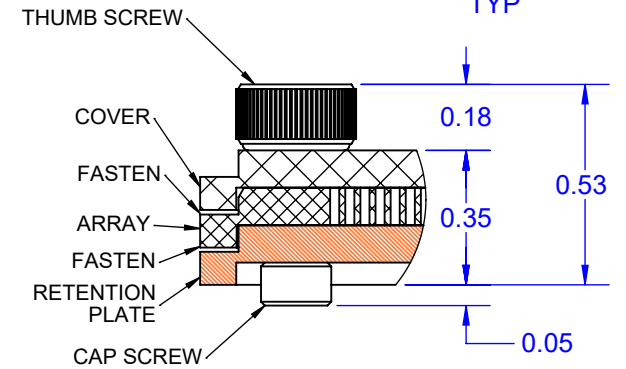
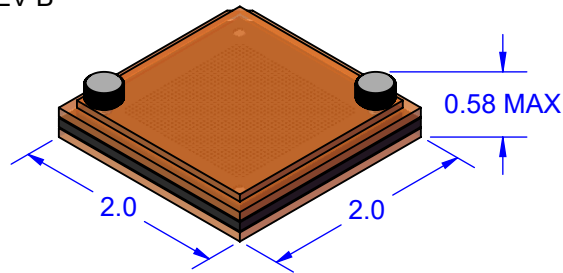

- NOTES:
1. DIMENSIONS IN INCHES.
 2. JEDEC OUTLINE.
 3. TEMPERATURE RATING: 60°C MAX.
 4. MATERIAL: ABS.
 5. SURFACE RESISTIVITY $10^3 \sim 10^9 \Omega$.
 6. COLOR: BLUE.
 7. POCKETS: HOLDS 8 PCS FLIP-PACK 2.0.
 8. COMPONENT SIZE: 2" x 2" x 0.58 inch.

APPROVALS	DATE	TopLine®			
DRAWN T. Au	02/14/16				
ENG M. Hart	02/14/16	TITLE FLIP PACK 2.0 CARRIER TRAY			
MFG		SCALE 1:2	SIZE A	DRAWING NO. 782200	REV B
QA		DO NOT SCALE DRAWING			SHEET 1 OF 9
CUST					
REVISED					

JEDEC PICK AND PLACE X / Y COORDINATES

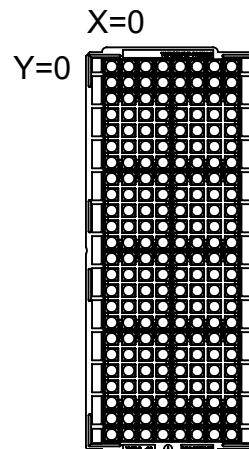
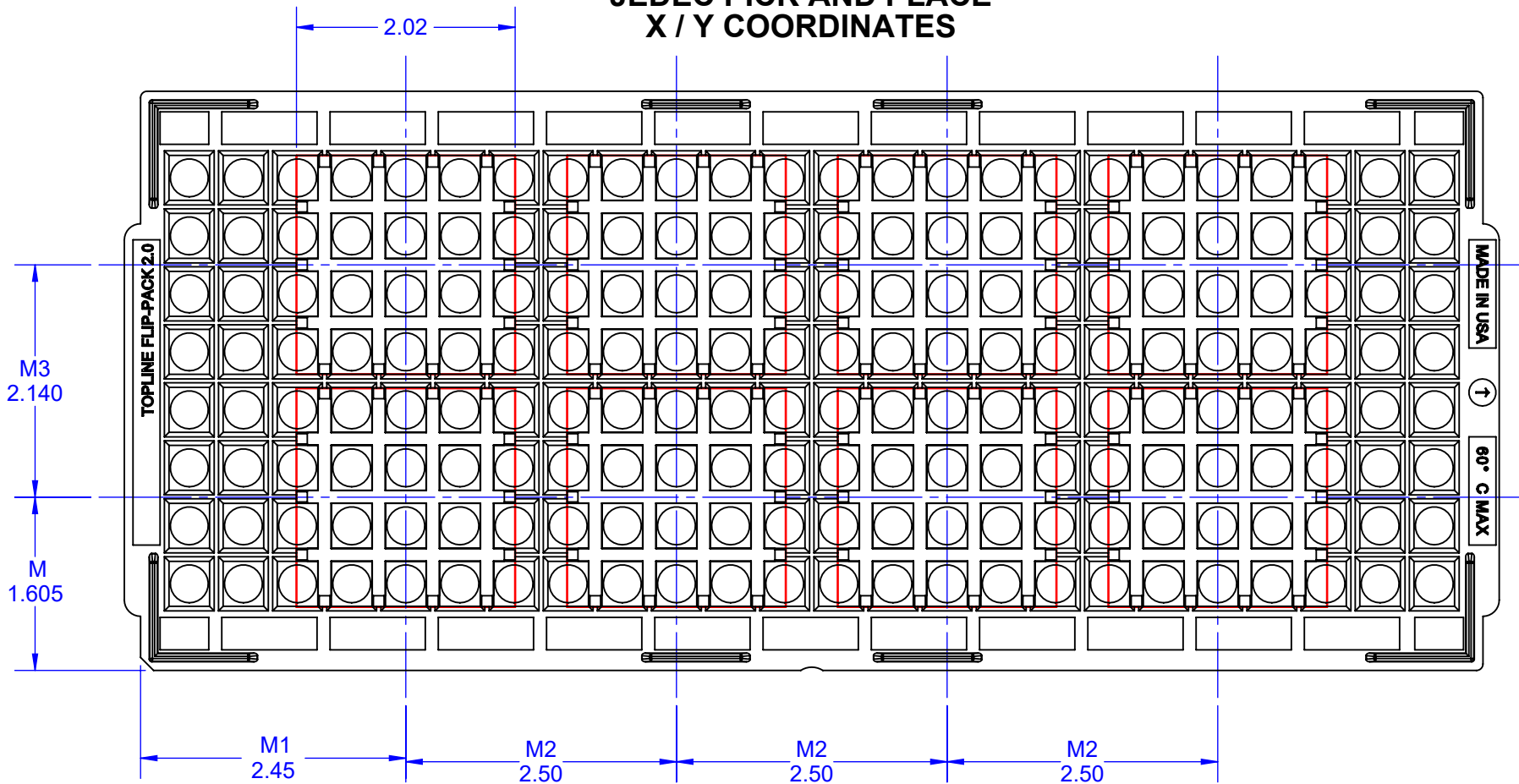

Pockets N3	Columns N1	Rows N2	Row 1 M	Col 1 M1	Col 2 M2	Row 2 M3
8	4	2	1.605	2.45	2.50	2.140

NOTES:
 JEDEC X-Y ORIENTATION ROTATED 90°.
 M FIRST STEP IN X DIRECTION.
 M1 FIRST STEP IN Y DIRECTION.
 M2 Y-AXIS STEP.
 M3 X-AXIS STEP.

JEDEC X-Y ORIENTATION

TopLine®			
TITLE		FLIP PACK 2.0 CARRIER TRAY	
SCALE	SIZE	DRAWING NO.	REV
2:3	A	782200	B
DO NOT SCALE DRAWING			SHEET 2 OF 9

**MODEL
JEDEC OUTLINE CARRIER TRAY
FOR 2-INCH FLIP PACK REV B**

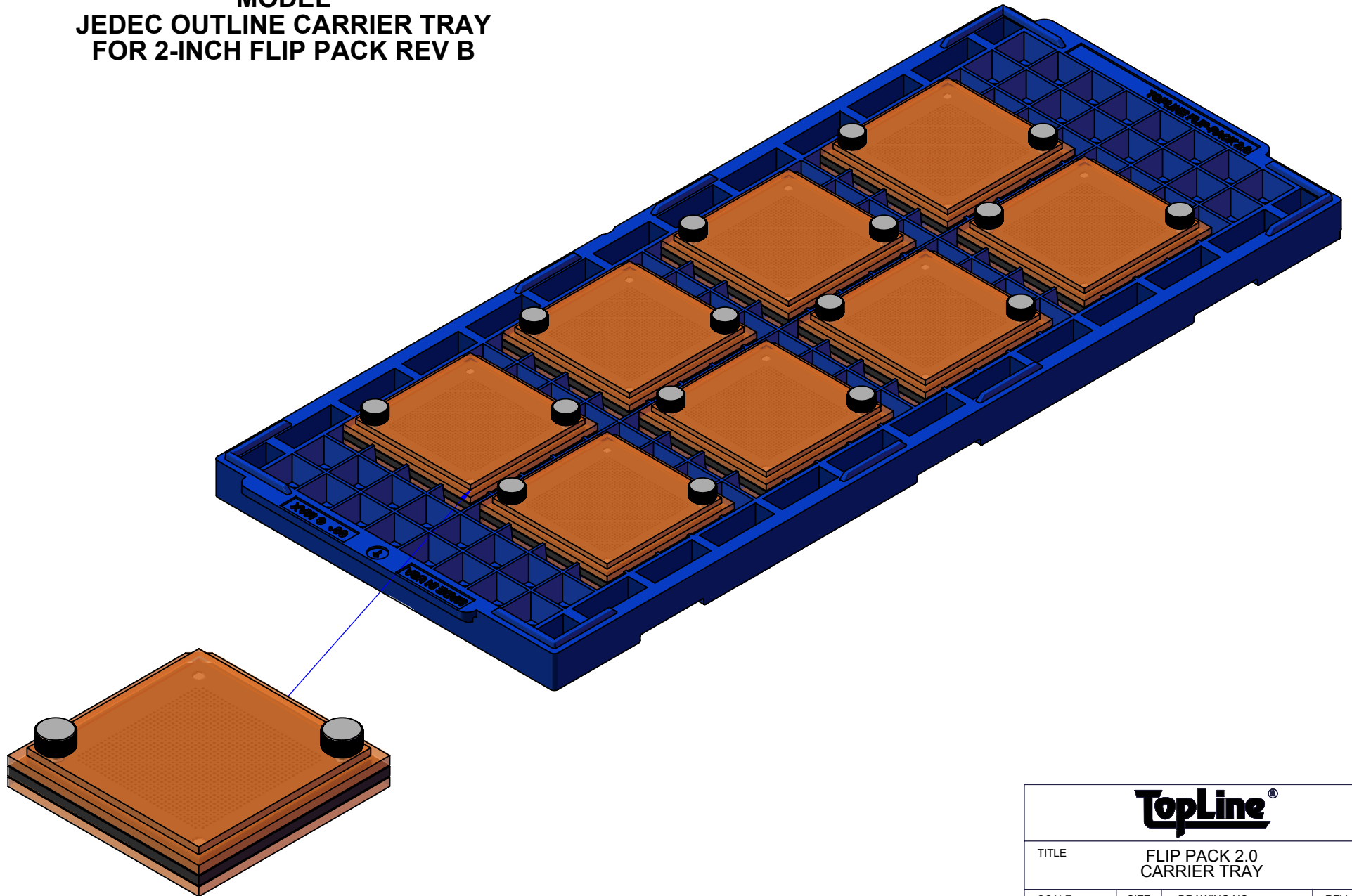

TopLine®			
TITLE		FLIP PACK 2.0 CARRIER TRAY	
SCALE	SIZE	DRAWING NO.	REV
2:3	A	782200	B
DO NOT SCALE DRAWING			SHEET 3 OF 9

**MODEL
JEDEC OUTLINE CARRIER TRAY
FOR 2-INCH FLIP PACK REV A**

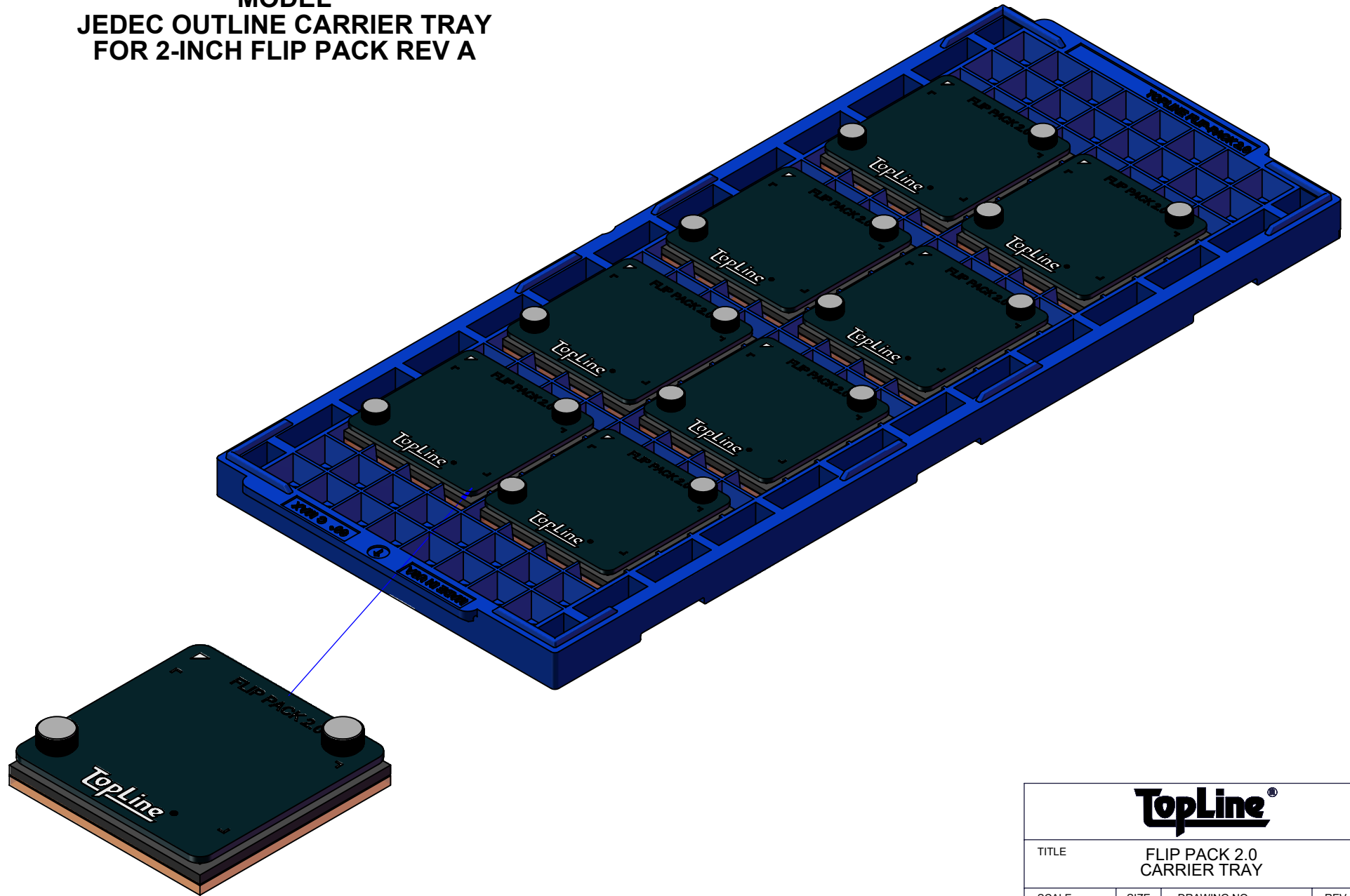

TopLine[®]			
TITLE		FLIP PACK 2.0 CARRIER TRAY	
SCALE	SIZE	DRAWING NO.	REV
2:3	A	782200	B
DO NOT SCALE DRAWING			SHEET 4 OF 9

SIDE VIEW

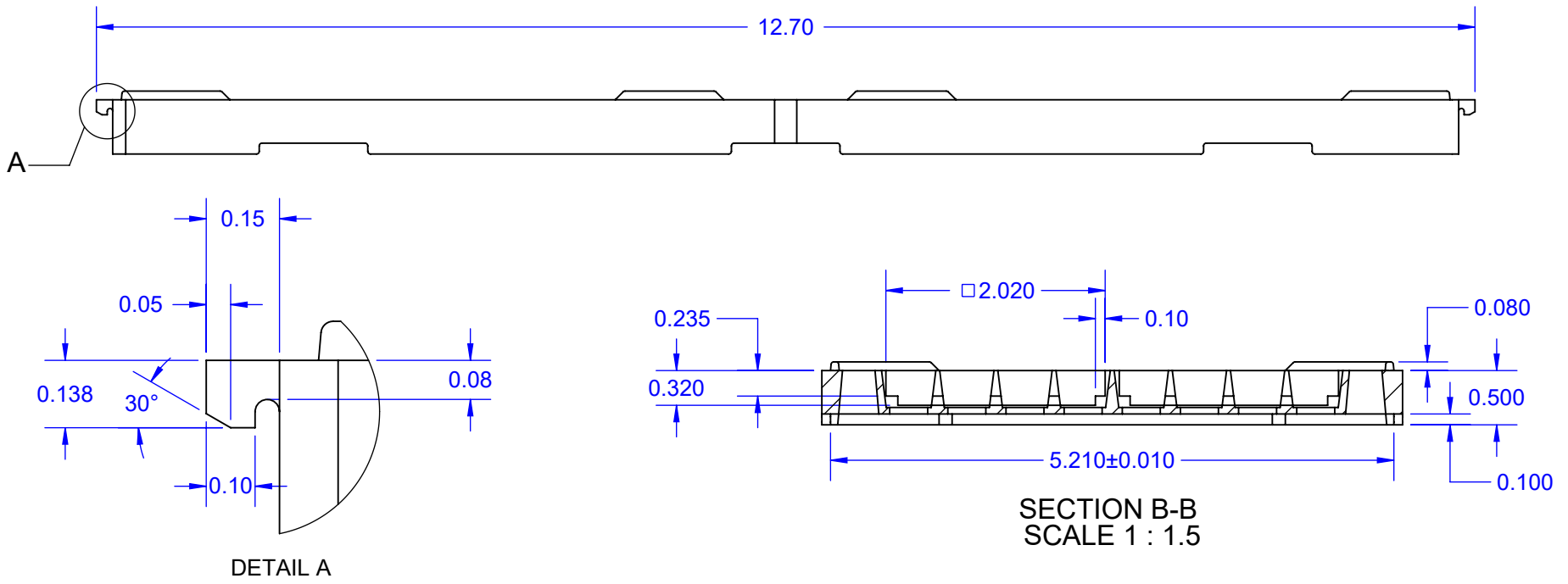

DETAIL A

SECTION B-B
SCALE 1 : 1.5

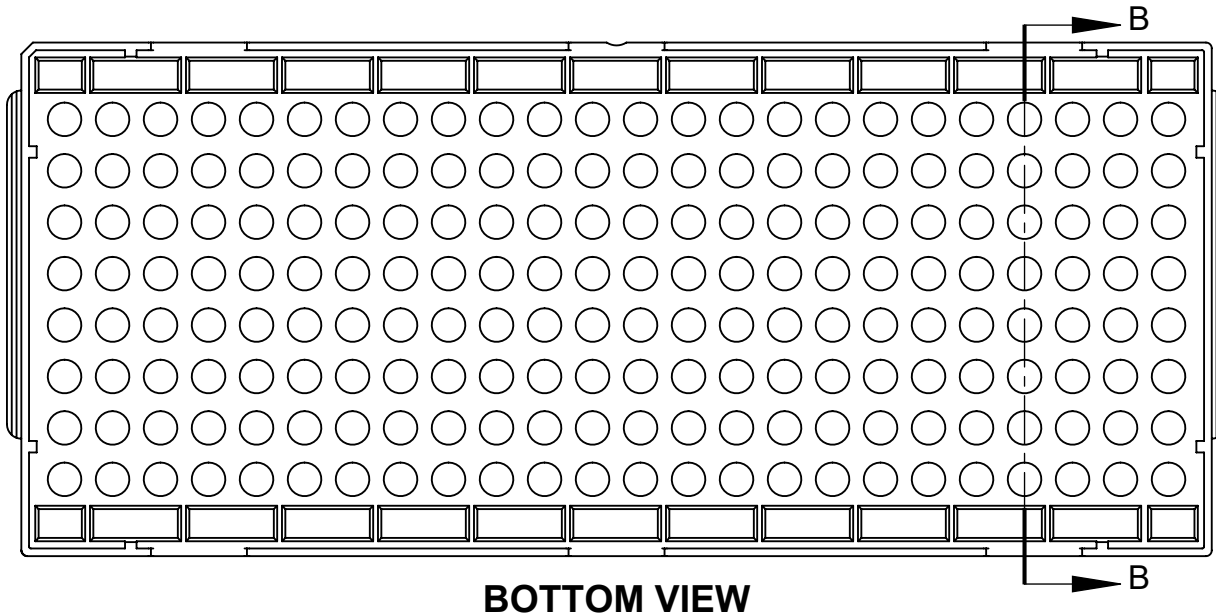

BOTTOM VIEW

TopLine®			
TITLE		FLIP PACK 2.0 CARRIER TRAY	
SCALE	SIZE	DRAWING NO.	REV
2:3	A	782200	B
DO NOT SCALE DRAWING			SHEET 5 OF 9

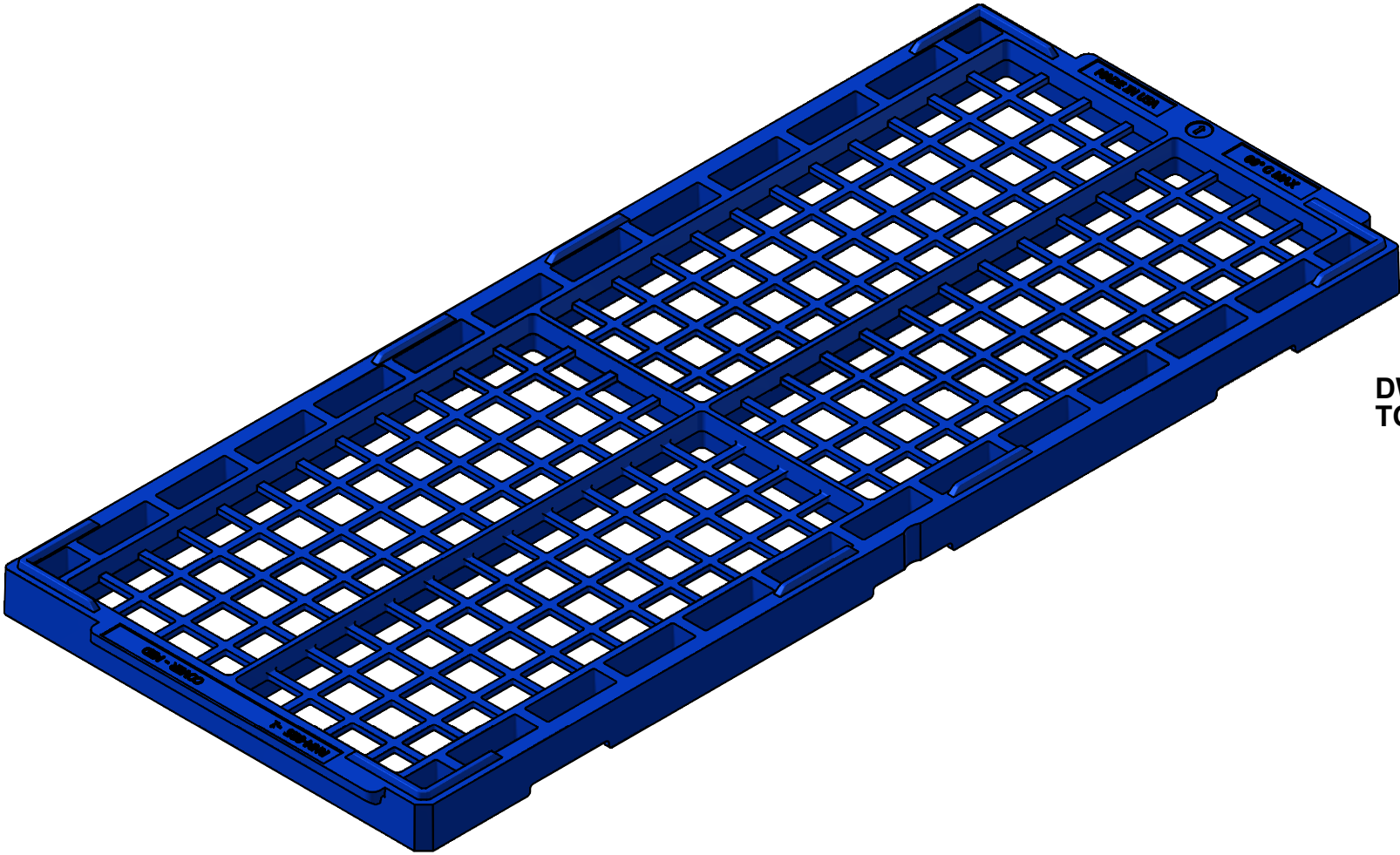

DWG 782250
TOP COVER

TopLine®			
TITLE		FLIP PACK 2.0 TOP COVER	
SCALE	SIZE	DRAWING NO.	REV
2:3	A	782250	A
DO NOT SCALE DRAWING			SHEET 6 OF 9

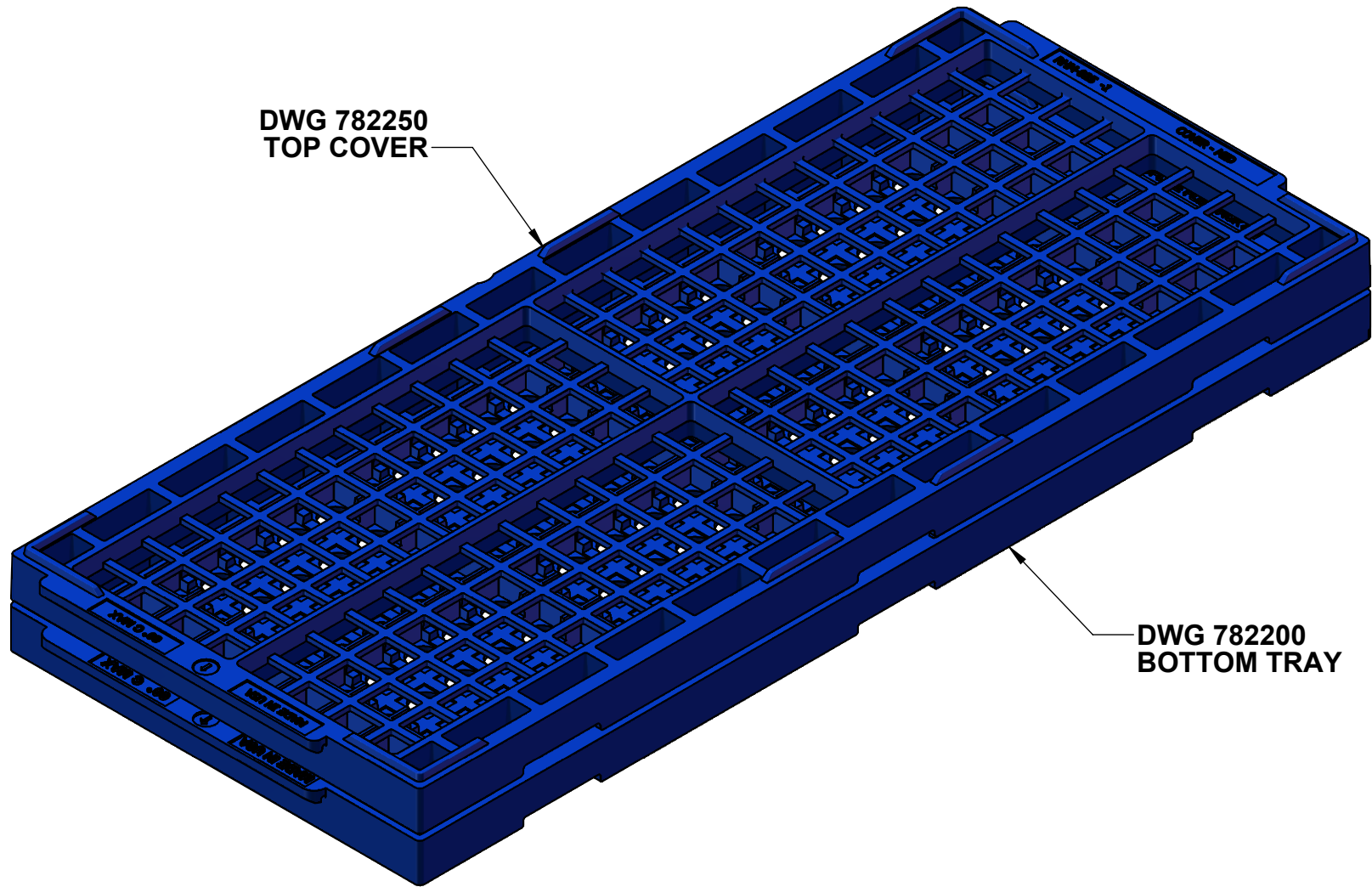

DWG 782250
TOP COVER

DWG 782200
BOTTOM TRAY

TopLine[®]

TITLE FLIP PACK 2.0
TOP COVER

SCALE	SIZE	DRAWING NO.	REV
2:3	A	782250	A

DO NOT SCALE DRAWING

SHEET 7 OF 9

TOP VIEW

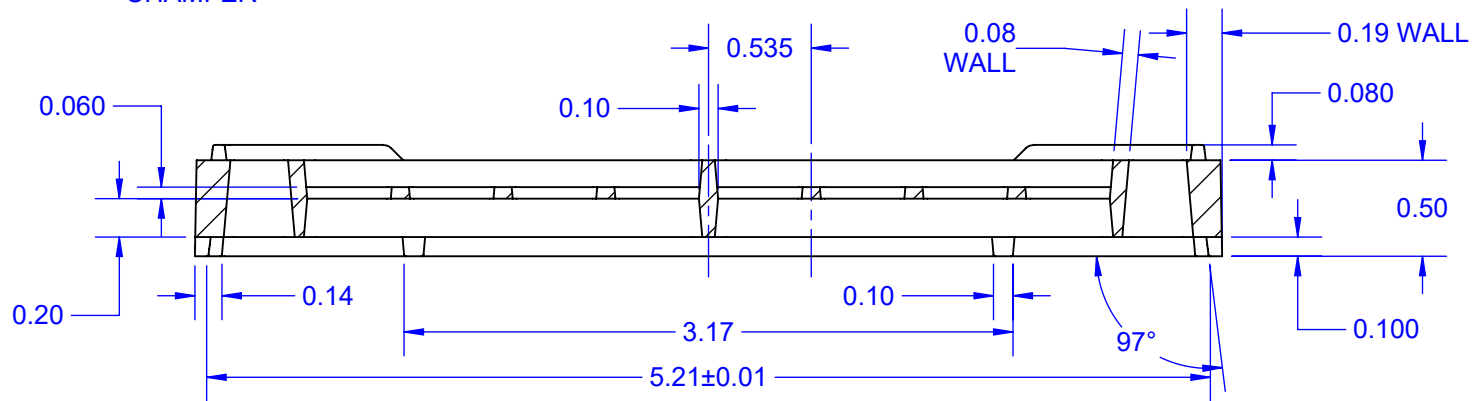
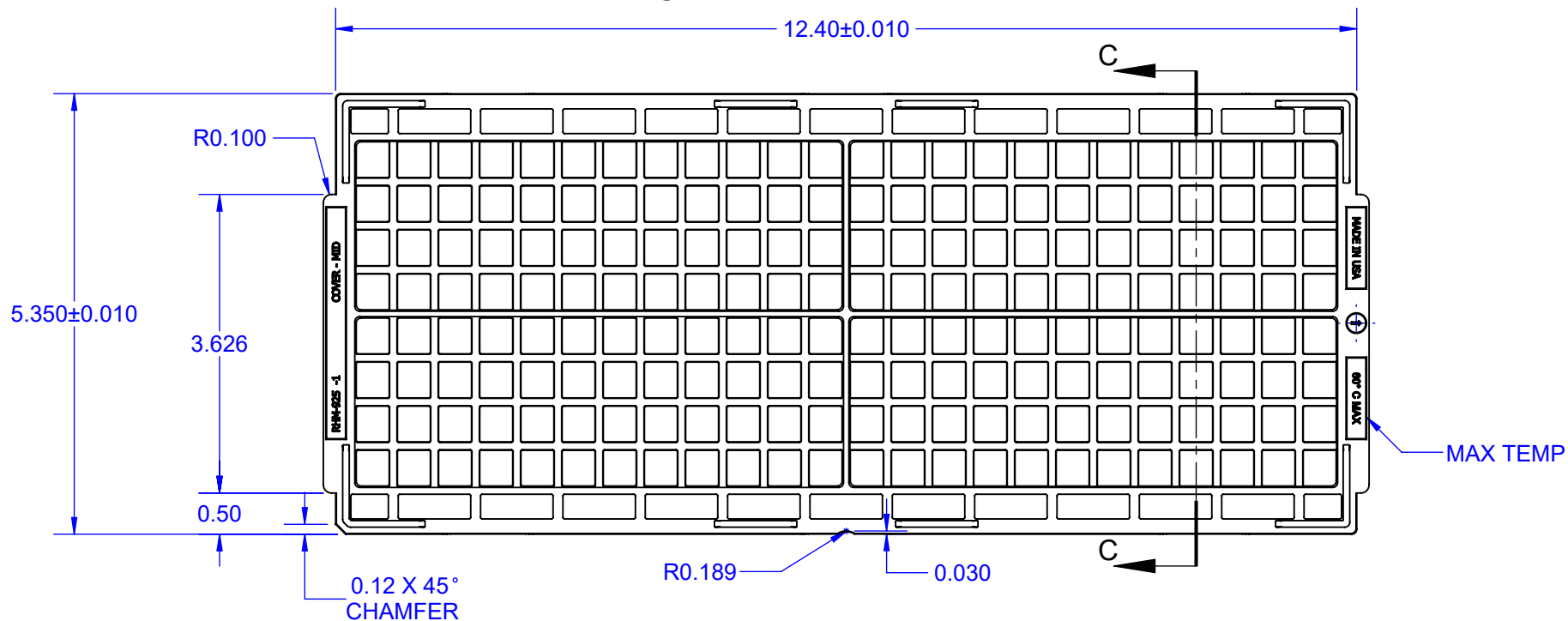

SECTION C-C

NOTES:

1. DIMENSIONS IN INCHES.
2. JEDEC OUTLINE.
3. TEMPERATURE RATING: 60°C MAX.
4. MATERIAL: ABS.
5. SURFACE RESISTIVITY $10^3 \sim 10^9 \Omega$.
6. COLOR: BLUE.

TopLine®

TITLE		FLIP PACK 2.0 TOP COVER	
SCALE	SIZE	DRAWING NO.	REV
1:2	A	782250	A
DO NOT SCALE DRAWING			SHEET 8 OF 9

ALTERNATE COVER (Rev B)

TOP

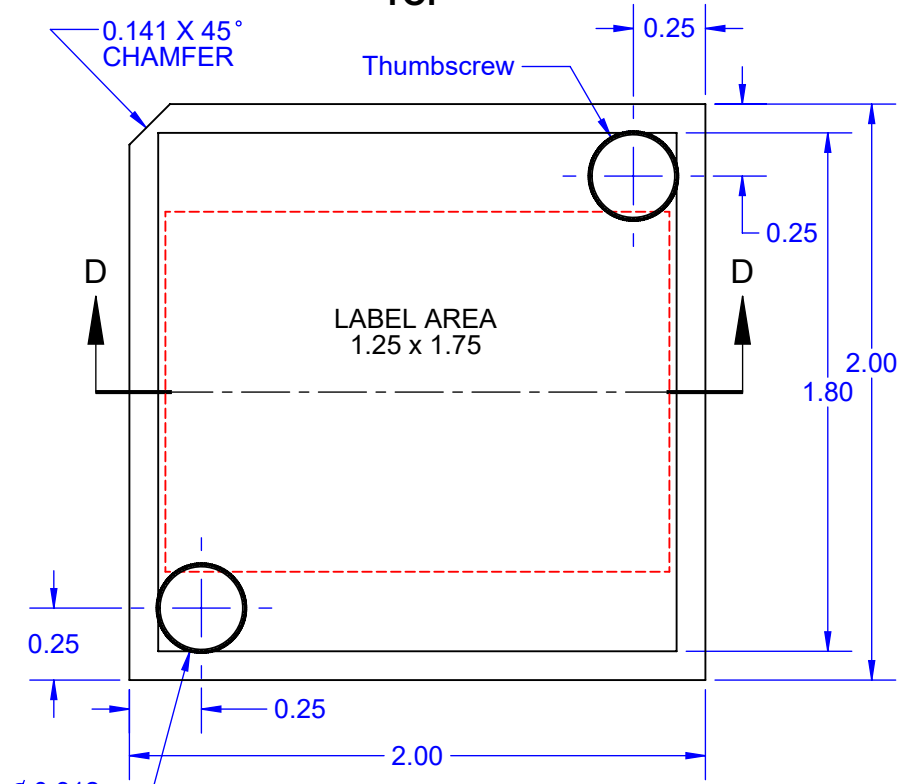

SIDE

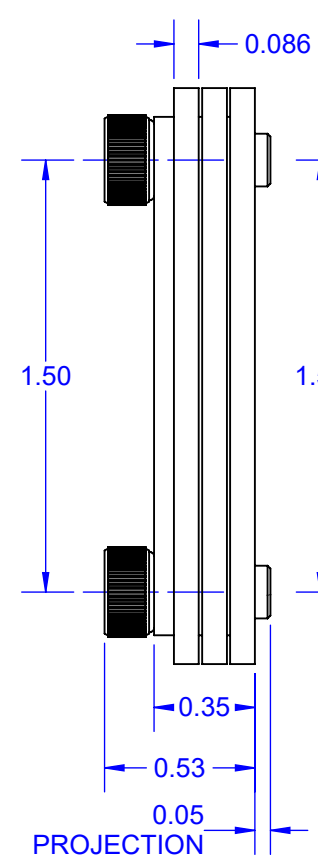

BOTTOM

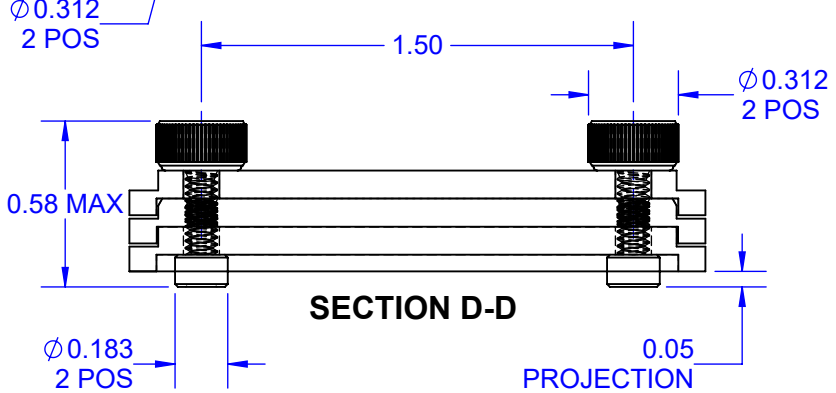
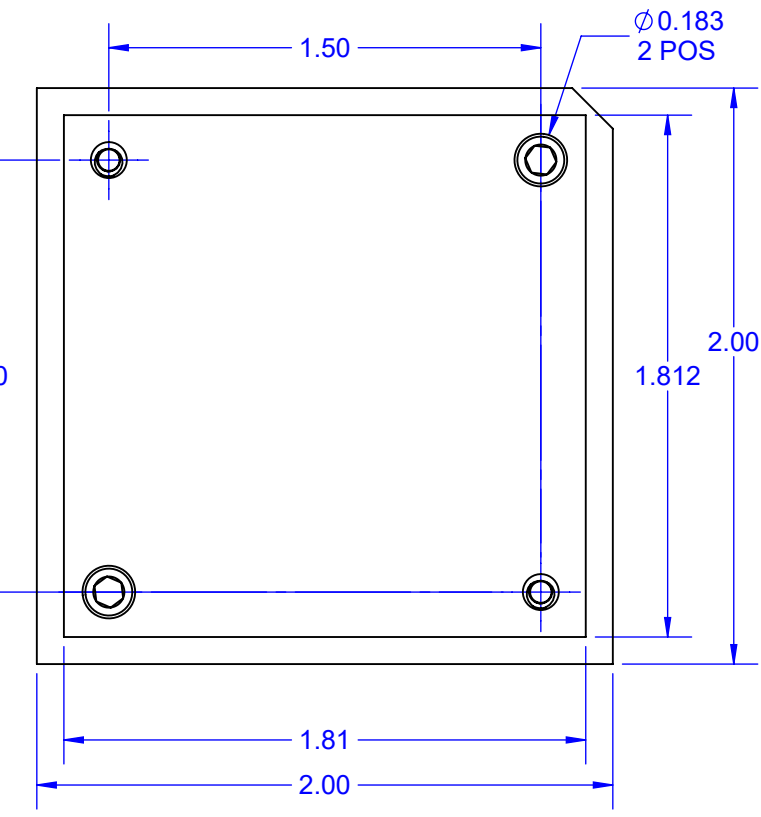

MODEL

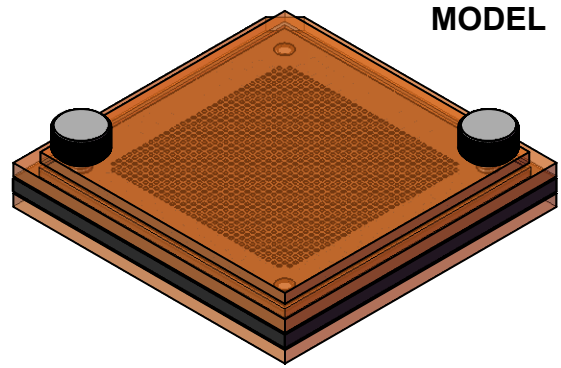

Notes: (Unless Otherwise Specified).
 1) MATERIAL: PLASTIC, ANTI-STATIC.
 2) DIMENSIONS: INCH.

TopLine®			
TITLE		FLIP PACK 2.0 CARRIER TRAY	
SCALE	SIZE	DRAWING NO.	REV
3:2	A	782200	B
DO NOT SCALE DRAWING			SHEET 9 OF 9