

SIDE VIEW

TOP VIEW

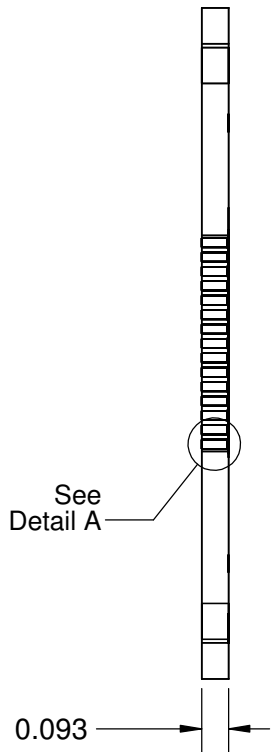

0.30 x 0.75
2 POS

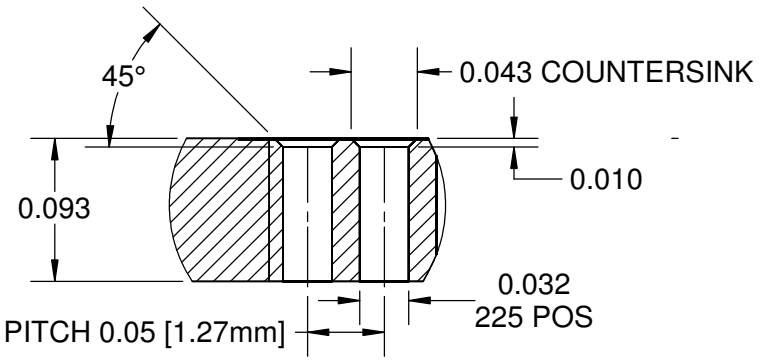
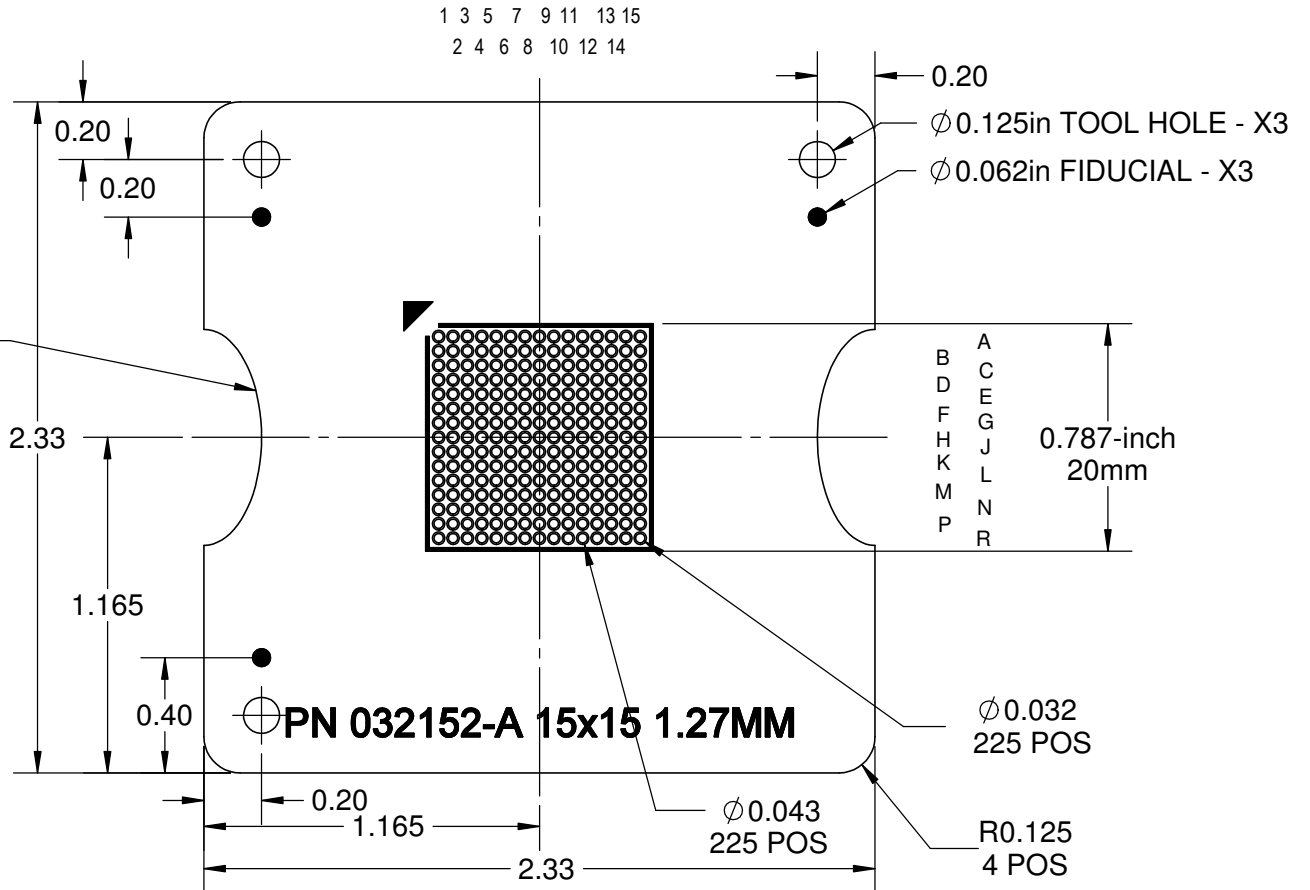

DETAIL A

- NOTES:
 1. DIMENSIONS IN INCH UNLESS OTHERWISE STATED.
 2. MATERIAL: FR4 COLOR BLACK.
 3. LEGEND: WHITE INK.
 4. PIN REFERENCE DESIGNATORS NOT MARKED ON PCB

APPROVALS	DATE	TopLine®			
DRAWN T. Au	9/13/2017				
ENG M. Hart	9/13/2017	TITLE CCGA225 TRAY INSERT 2.33" SQ			
MFG		SCALE	SIZE	DRAWING NO.	REV
QA		3:2	A	032152	A
CUST		DO NOT SCALE DRAWING			SHEET 1 OF 3
REVISED					

FAB DRILL AND PLATED THROUGH HOLES

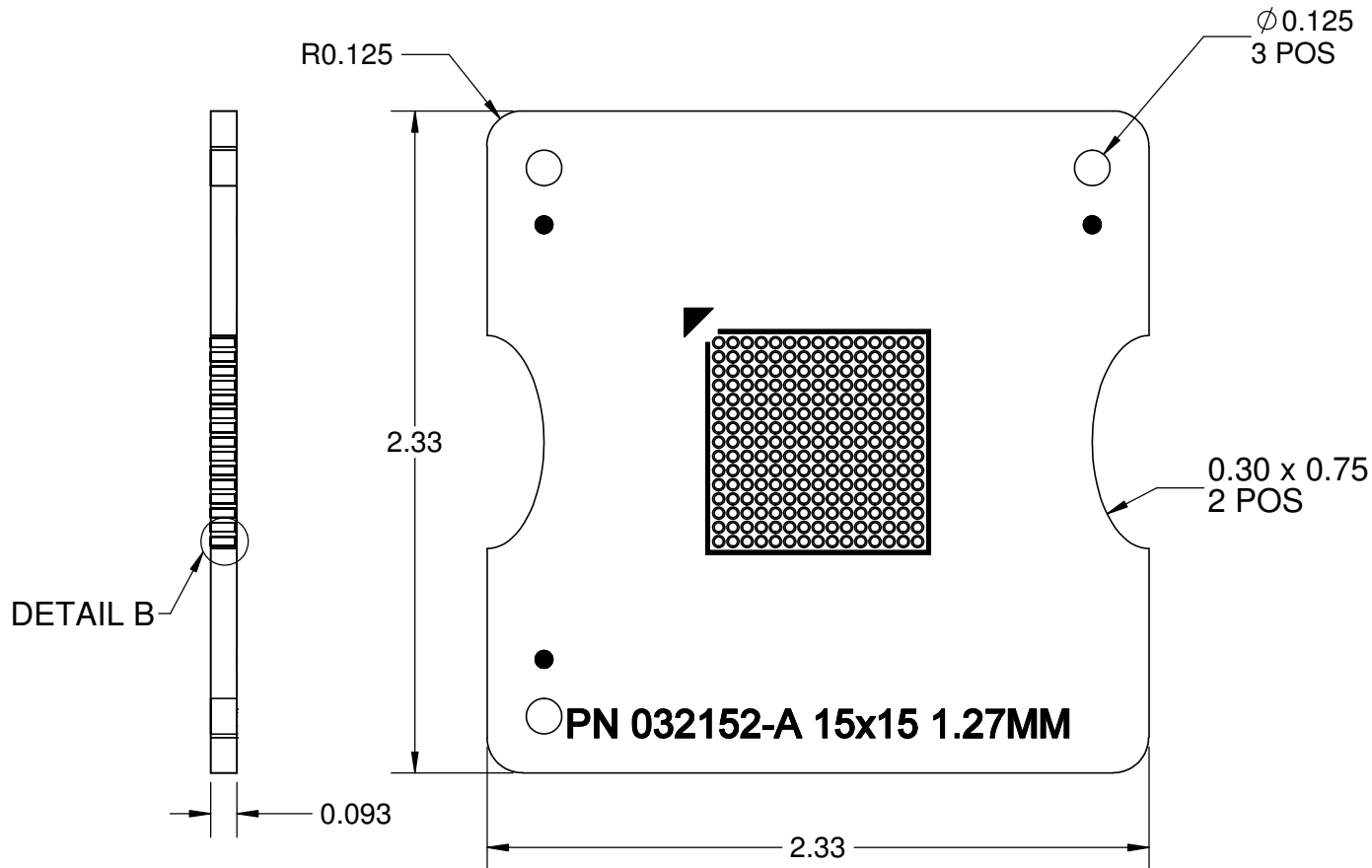

HOLE CHART			
SYMBOL	DIAMETER UNPLATED THRU	COUNTER SINK	QTY PCB
+	0.032±0.003	-	225
○	-	0.043±0.003	225
○	∅0.125		3
TOTAL			453

- FAB NOTES:**
1. MATERIAL:
A. NO COPPER (0/0).
B. G10 BLACK COLOR.
 2. REFER TO DETAIL A COUNTER SINK.
 3. REFER TO VIEW A FOR STACK UP.
 4. NO PTH HOLES.
 5. NO SOLDER MASK.
 6. NO PCB MFRG LOGO ALLOWED.
 7. SILKSCREEN WHITE INK.
 8. FULLY ROUTE EACH BOARD.

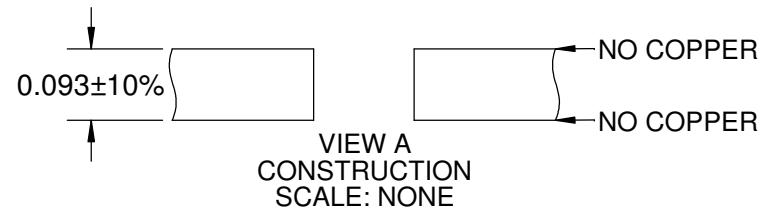
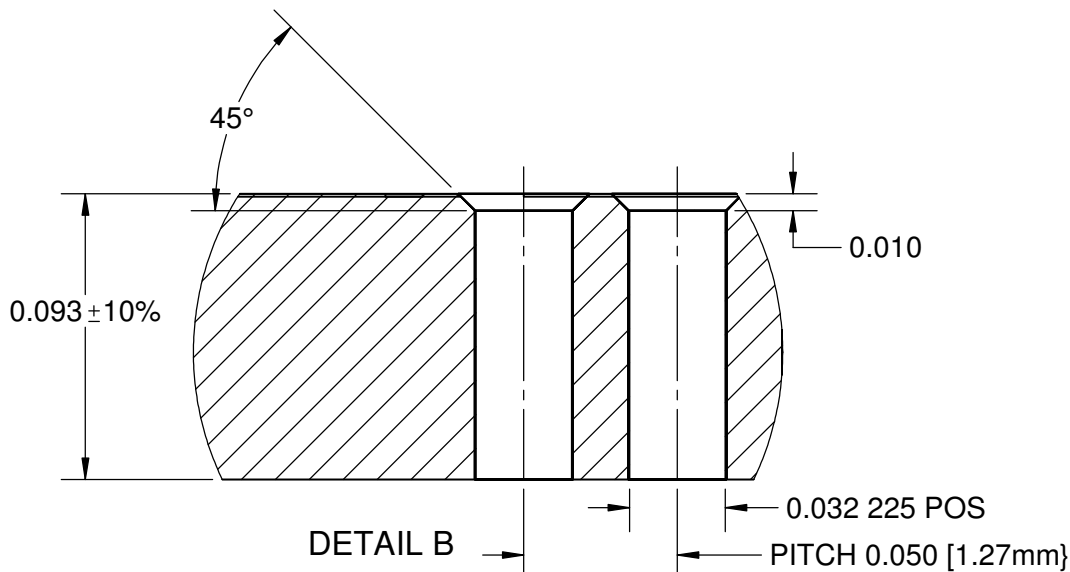

TopLine®			
TITLE CCGA225 TRAY INSERT 2.33" SQ			
SCALE 1.25:1	SIZE A	DRAWING NO. 032152	REV A
DO NOT SCALE DRAWING			SHEET 2 OF 3

MODEL

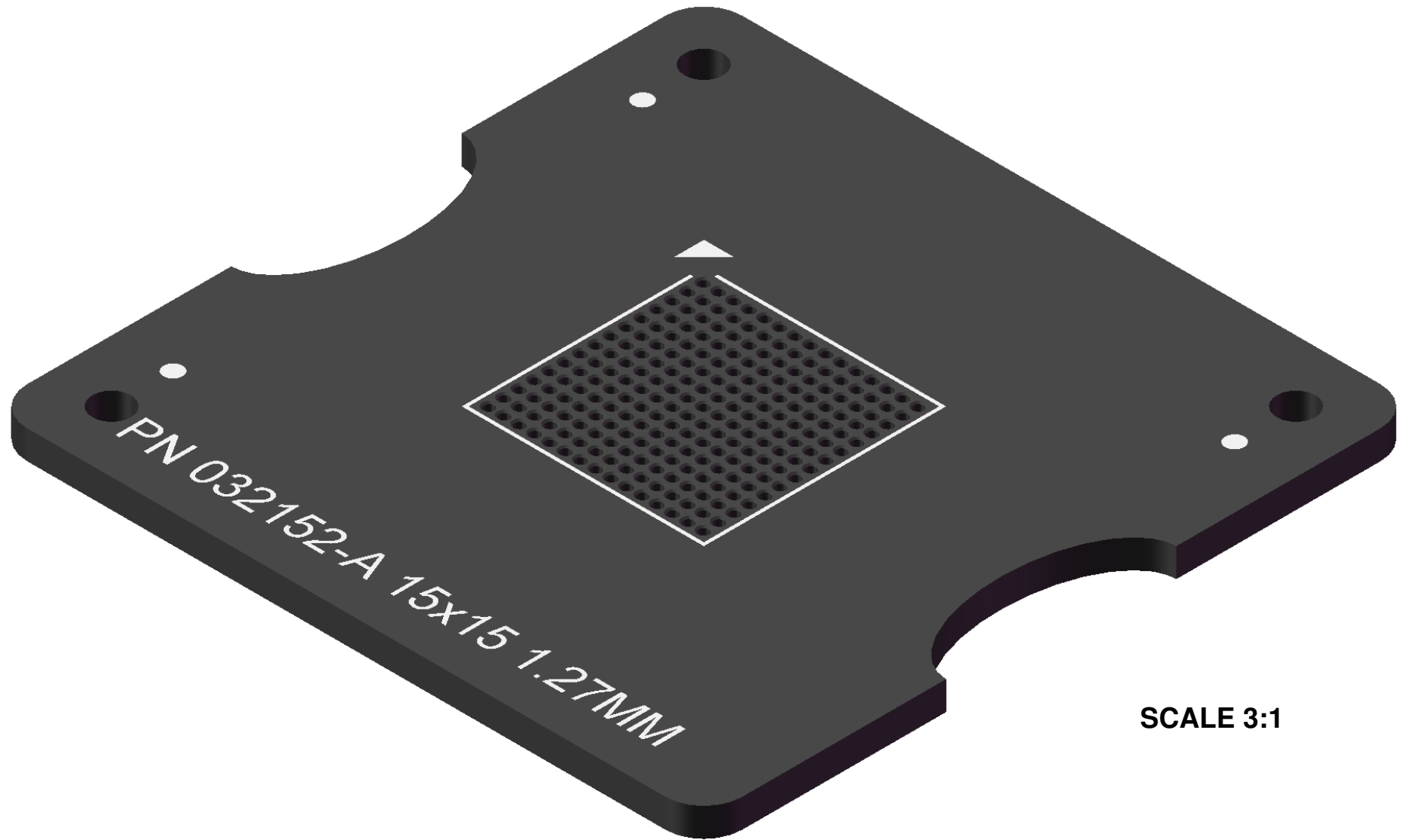

SCALE 3:1

TopLine[®]			
TITLE		CCGA225 TRAY INSERT 2.33" SQ	
SCALE	SIZE	DRAWING NO.	REV
3:1	A	032152	A
DO NOT SCALE DRAWING			SHEET 3 OF 3