

SIDE VIEW

TOP VIEW

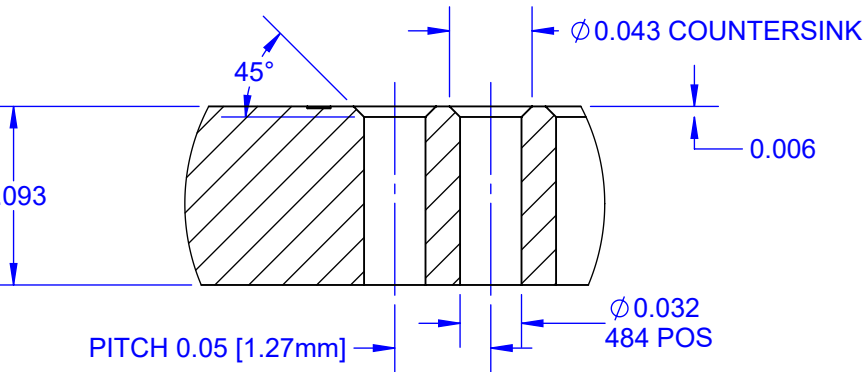
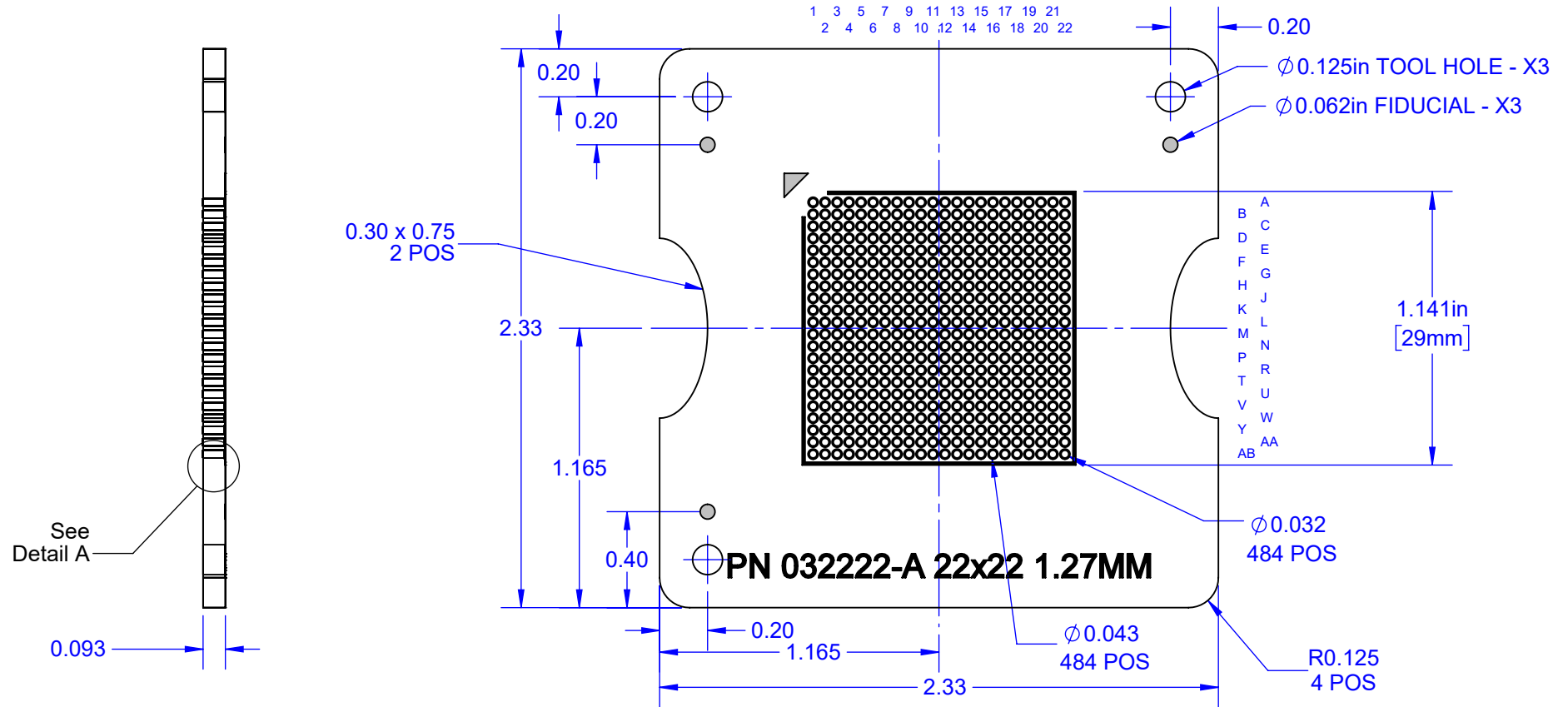

DETAIL A

NOTES:

1. DIMENSIONS IN INCH UNLESS OTHERWISE STATED.
2. MATERIAL: FR4 COLOR BLACK.
3. LEGEND: WHITE INK.
4. PIN REFERENCE DESIGNATORS NOT MARKED ON PCB

APPROVALS	DATE	TopLine®			
DRAWN T. Au	11/05/17				
ENG M. Hart	11/05/17	TITLE CCGA484 TRAY INSERT 2.33" SQ			
MFG		SCALE	SIZE	DRAWING NO.	REV
QA		3:2	A	032222	A
CUST		DO NOT SCALE DRAWING			SHEET 1 OF 3
REVISED					

FAB DRILL AND PLATED THROUGH HOLES

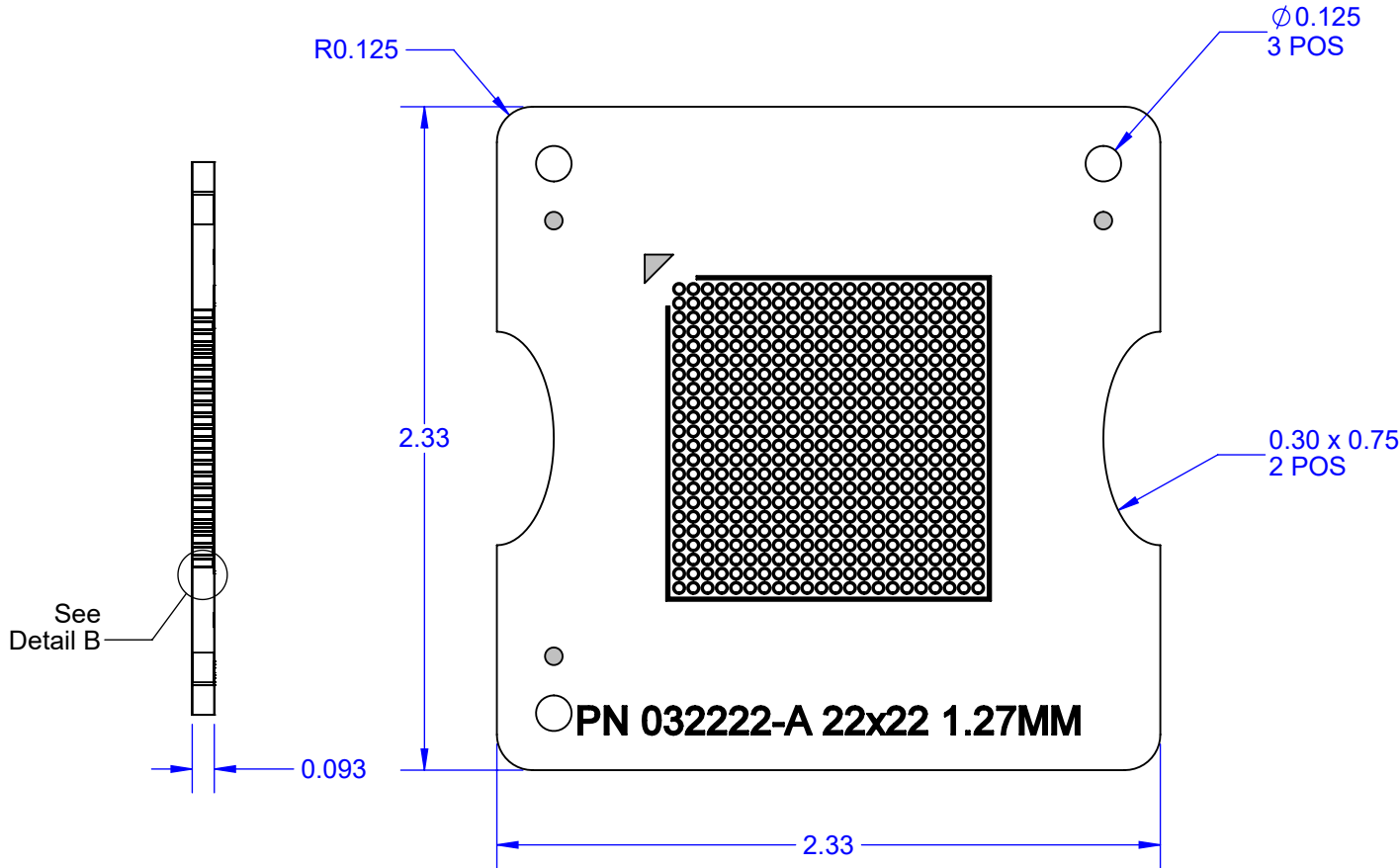

HOLE CHART			
SYMBOL	DIAMETER UNPLATED THRU	COUNTER SINK	QTY PCB
+	0.032±0.003	-	484
○	-	0.043±0.003	484
○	∅0.125		3
TOTAL			971

- FAB NOTES:
- MATERIAL:
 - A. NO COPPER (0/0).
 - B. G10 BLACK COLOR.
 - REFER TO DETAIL A COUNTER SINK.
 - REFER TO VIEW A FOR STACK UP.
 - NO PTH HOLES.
 - NO SOLDER MASK.
 - NO PCB MFRG LOGO ALLOWED.
 - SILKSCREEN WHITE INK.
 - FULLY ROUTE EACH BOARD.

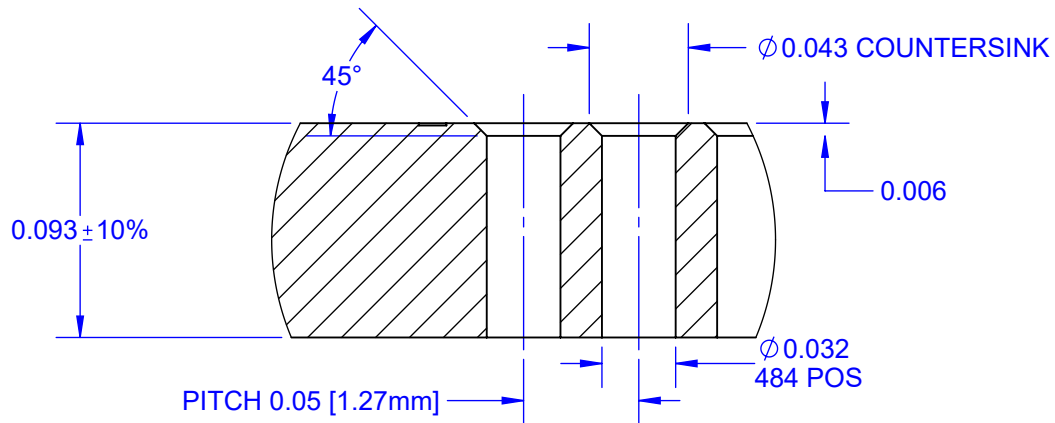

DETAIL B

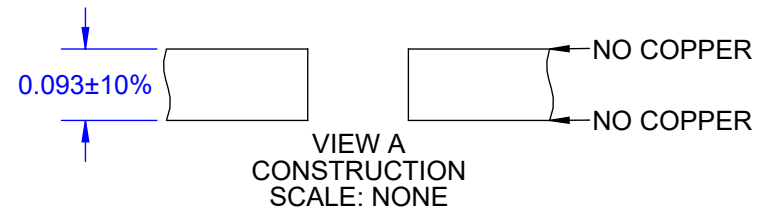

TopLine®			
TITLE CCGA484 TRAY INSERT 2.33" SQ			
SCALE 1.25:1	SIZE A	DRAWING NO. 032222	REV A
DO NOT SCALE DRAWING			SHEET 2 OF 3

MODEL

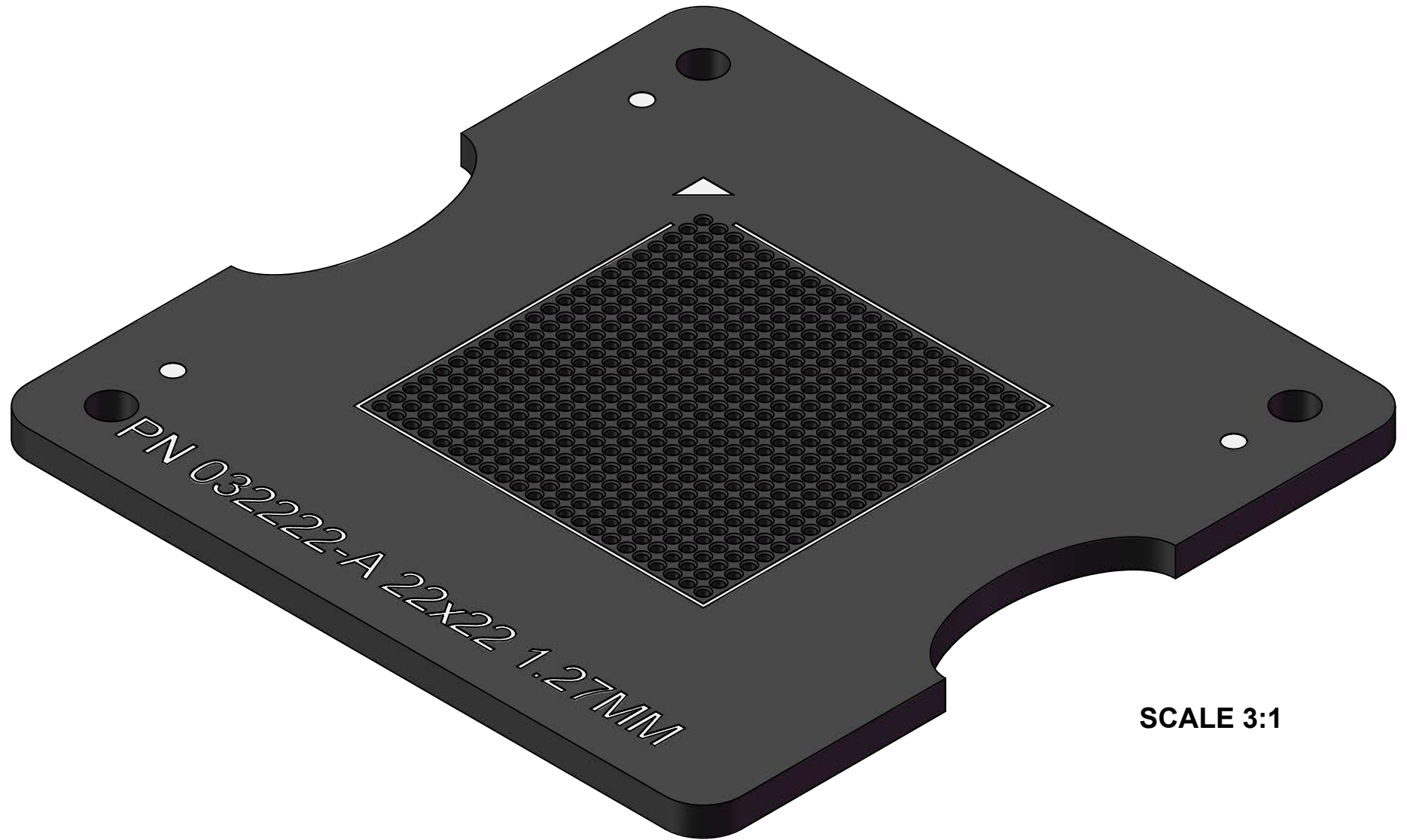

SCALE 3:1

TopLine[®]			
TITLE		CCGA484 TRAY INSERT 2.33" SQ	
SCALE	SIZE	DRAWING NO.	REV
3:1	A	032222	A
DO NOT SCALE DRAWING			SHEET 3 OF 3