

SIDE VIEW

TOP VIEW

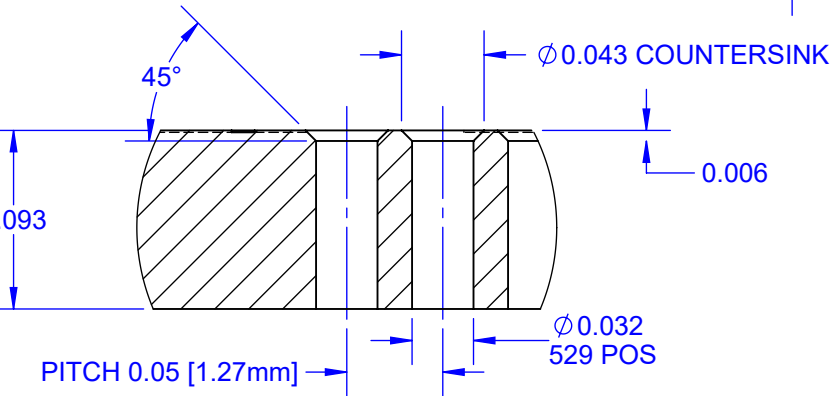
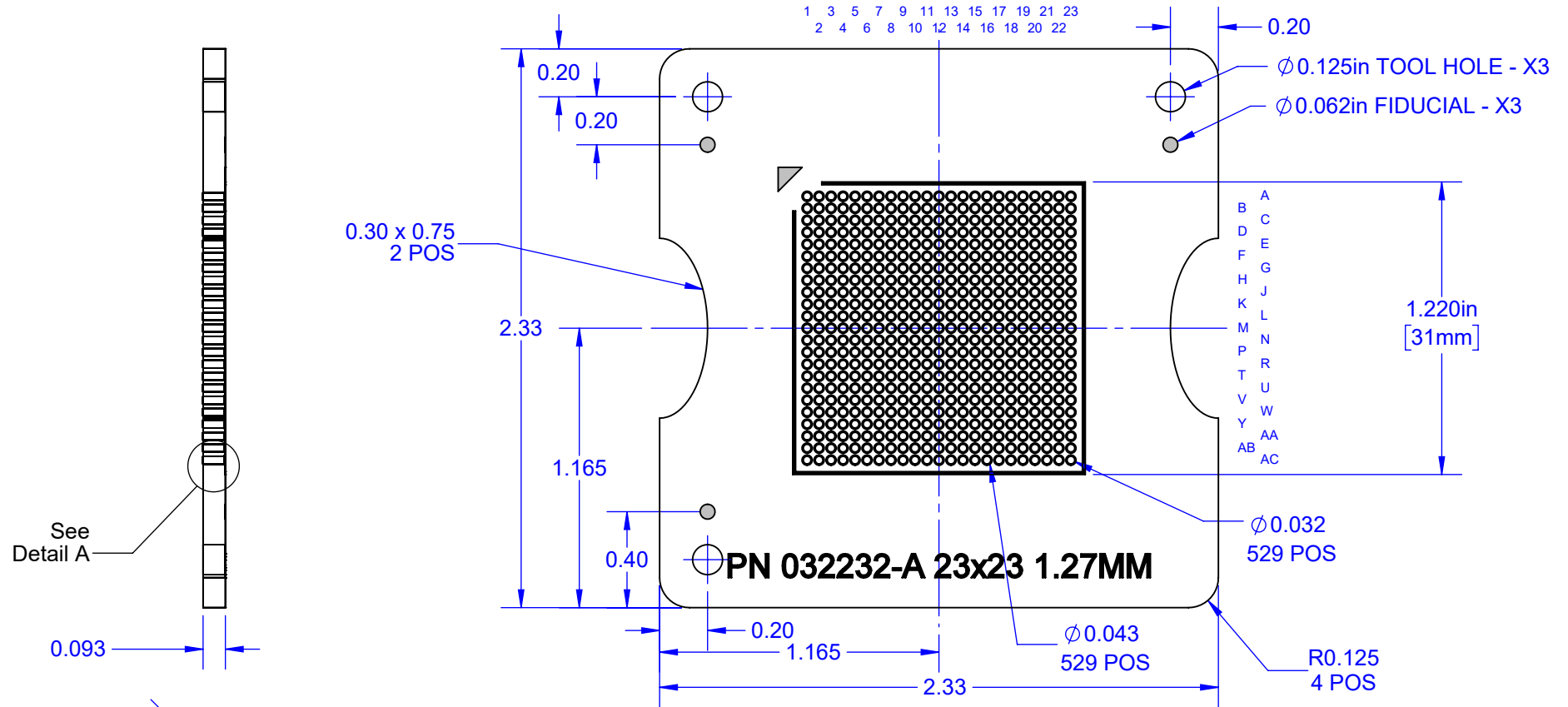

DETAIL A

- NOTES:**
1. DIMENSIONS IN INCH UNLESS OTHERWISE STATED.
 2. MATERIAL: FR4 COLOR BLACK.
 3. LEGEND: WHITE INK.
 4. PIN REFERENCE DESIGNATORS NOT MARKED ON PCB

APPROVALS	DATE	TopLine®			
DRAWN T. Au	11/05/17				
ENG M. Hart	11/05/17	TITLE CCGA529 TRAY INSERT 2.33" SQ			
MFG		SCALE	SIZE	DRAWING NO.	REV
QA		3:2	A	032232	A
CUST		DO NOT SCALE DRAWING			SHEET 1 OF 3
REVISED					

FAB DRILL AND PLATED THROUGH HOLES

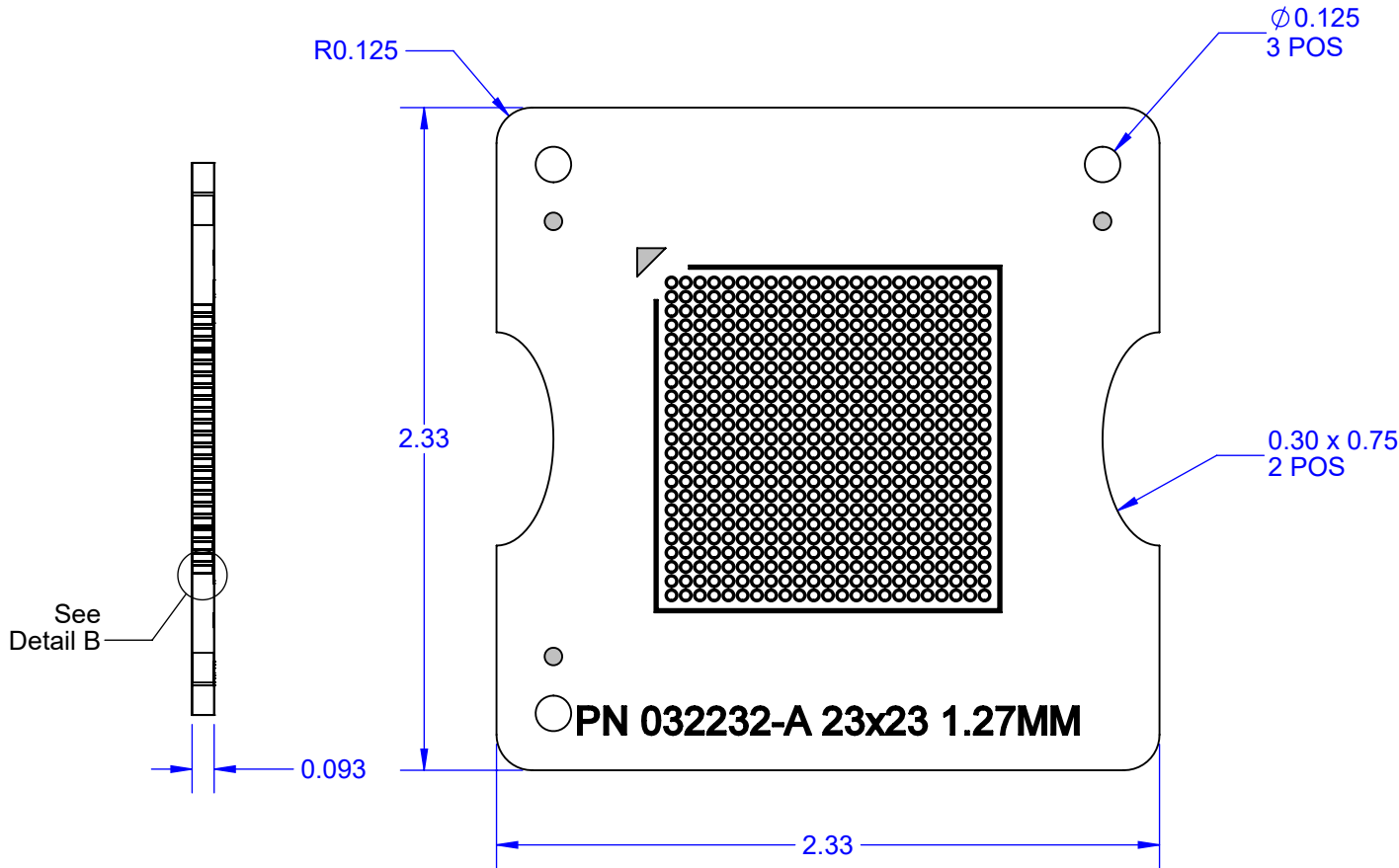

HOLE CHART			
SYMBOL	DIAMETER UNPLATED THRU	COUNTER SINK	QTY PCB
+	0.032±0.003	-	529
○	-	0.043±0.003	529
○	∅0.125		3
TOTAL			1061

FAB NOTES:

- MATERIAL:
 - NO COPPER (0/0).
 - G10 BLACK COLOR.
- REFER TO DETAIL A COUNTER SINK.
- REFER TO VIEW A FOR STACK UP.
- NO PTH HOLES.
- NO SOLDER MASK.
- NO PCB MFGR LOGO ALLOWED.
- SILKSCREEN WHITE INK.
- FULLY ROUTE EACH BOARD.

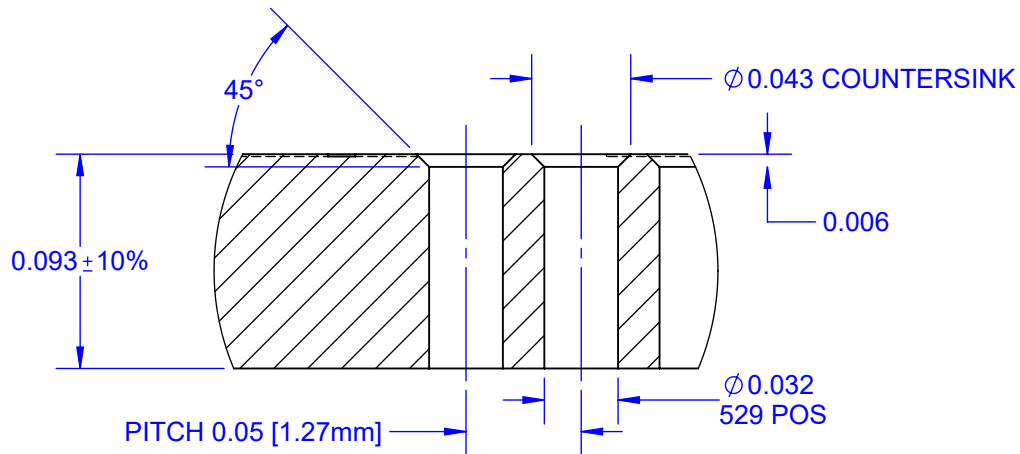

DETAIL B

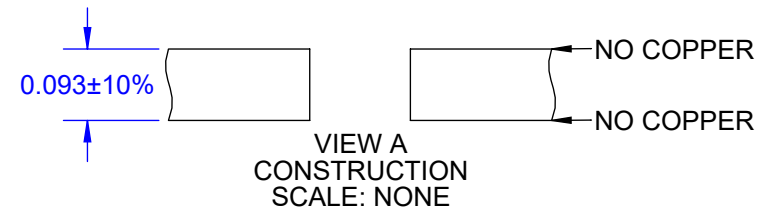

			
TITLE CCGA529 TRAY INSERT 2.33" SQ			
SCALE 1.25:1	SIZE A	DRAWING NO. 032232	REV A
DO NOT SCALE DRAWING			SHEET 2 OF 3

MODEL

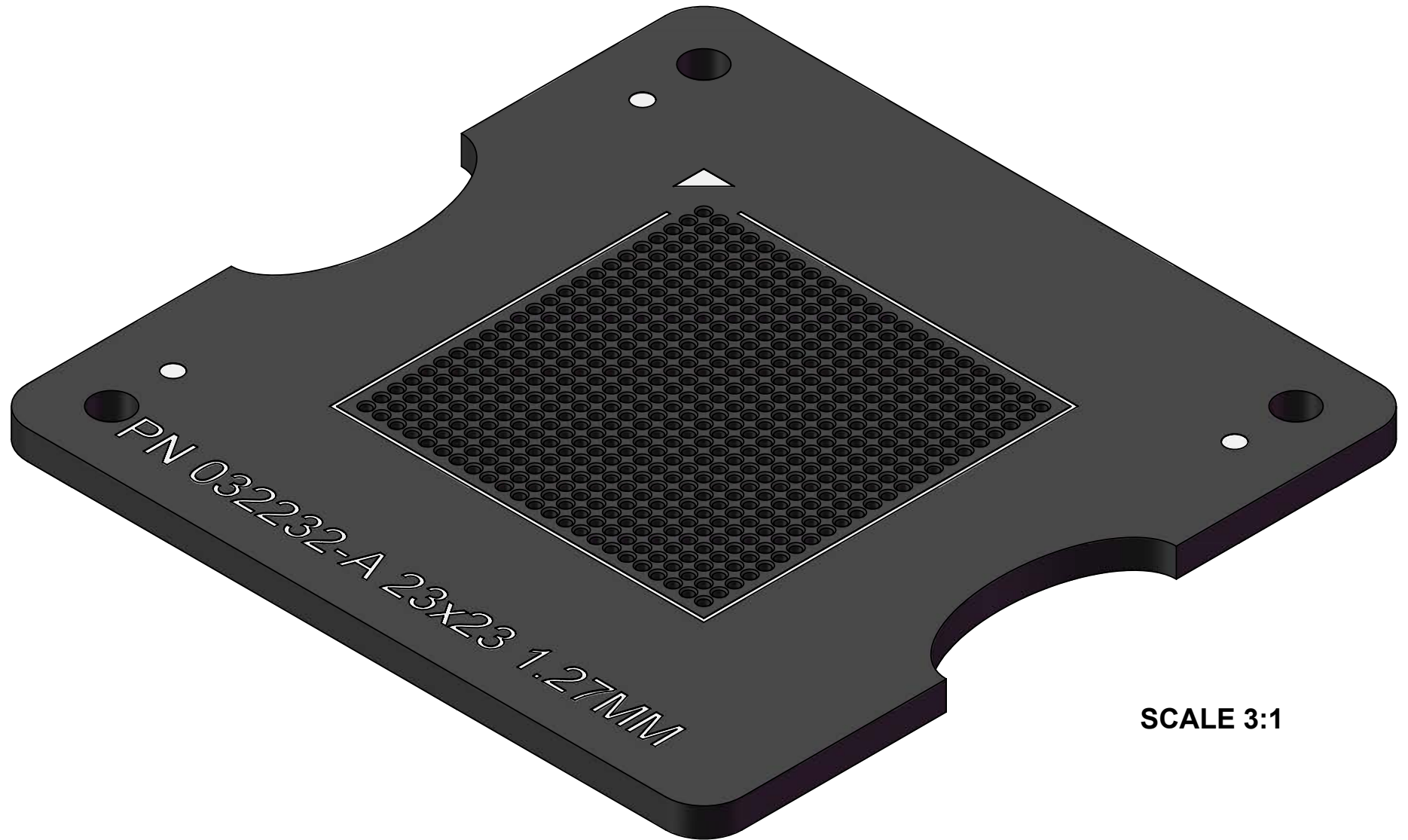

SCALE 3:1

TopLine[®]			
TITLE		CCGA529 TRAY INSERT 2.33" SQ	
SCALE	SIZE	DRAWING NO.	REV
3:1	A	032232	A
DO NOT SCALE DRAWING			SHEET 3 OF 3