

>9897'D7?5B8'D@79
L#M7CCF8-B5H9G

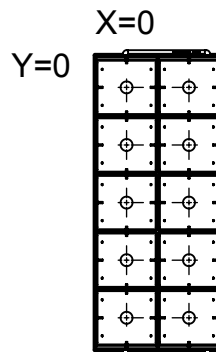
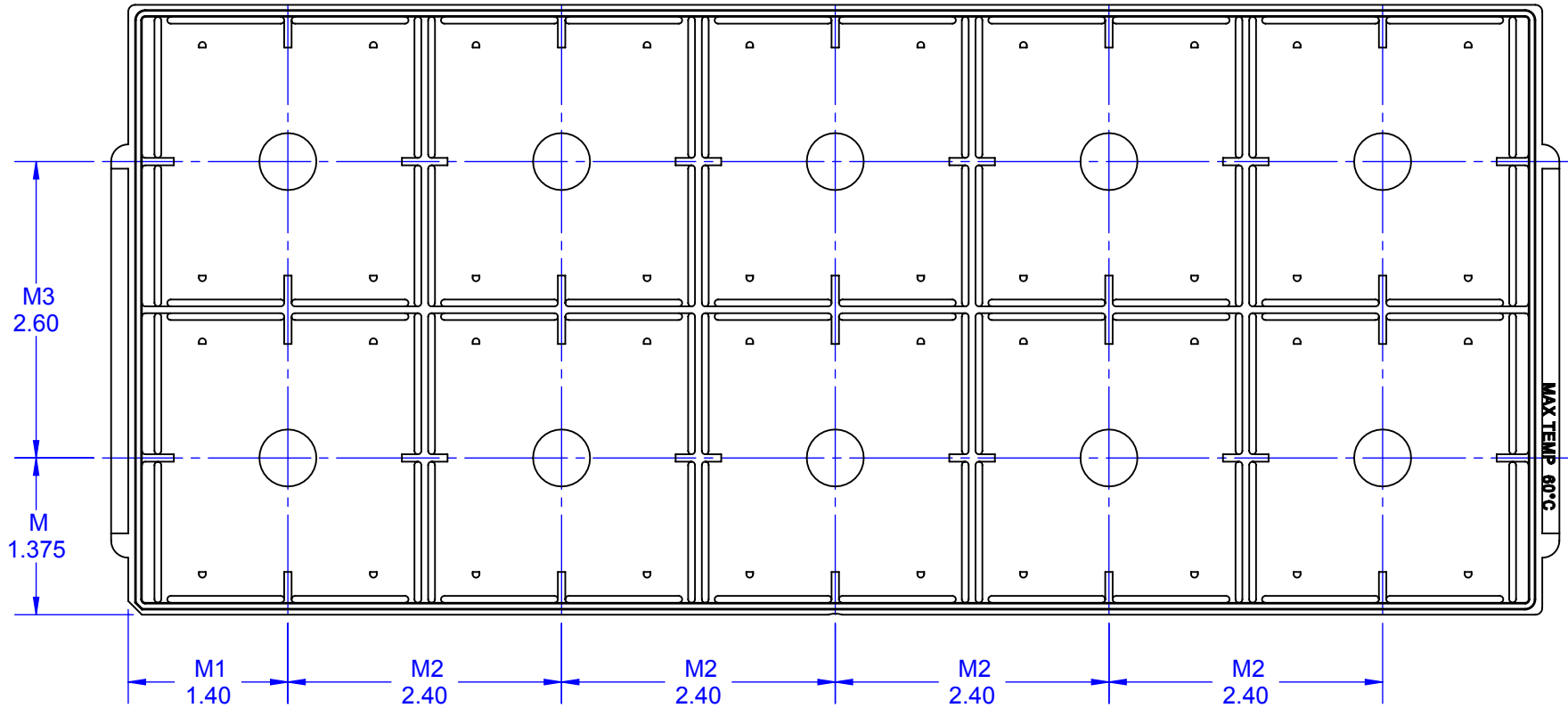

JEDEC
X-Y ORIENTATION

NOTES:
JEDEC X-Y ORIENTATION ROTATED 90°.
M FIRST STEP IN X DIRECTION.
M1 FIRST STEP IN Y DIRECTION.
M2 Y-AXIS STEP.
M3 X-AXIS STEP.

| | | | |
|---|-----------|-----------------------|--------------|
| TopLine® | | | |
| TITLE WP2-JIGTRAY-BLUE JEDEC OUTLINE CARRIER | | | |
| SCALE 2:3 | SIZE A | DRAWING NO. 782360 | REV A |
| DO NOT SCALE DRAWING | | | SHEET 2 OF 4 |

AC89@
 >9897`CI H@B9`6 @ 9`75FF-9F`HF5 M
 : CF`-B7<`K5:: @ `D57?G
 f) \$", a a `7`7<-D`HF5 MGL

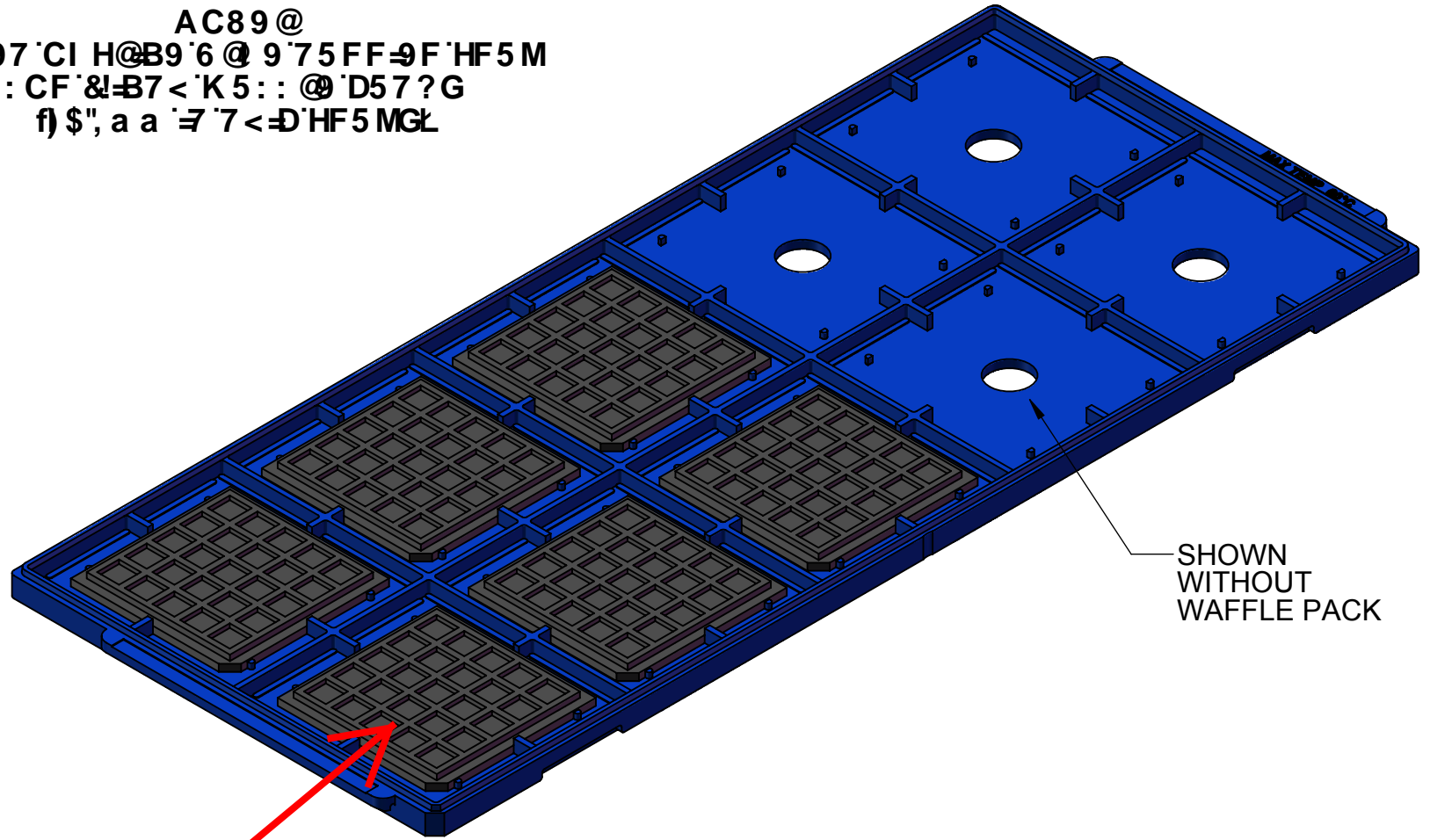

SHOWN
 WITHOUT
 WAFFLE PACK

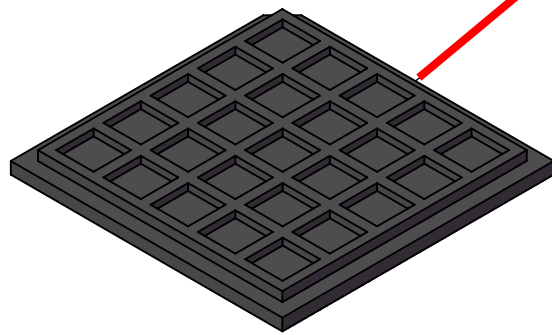

SHOWN WITH
 EXAMPLE 2-INCH
 WAFFLE PACK

TopLine[®]

TITLE WP2-JIGTRAY-BLUE
 JEDEC OUTLINE CARRIER

| | | | |
|--------------|-----------|-----------------------|----------|
| SCALE 2:3 | SIZE A | DRAWING NO. 782360 | REV A |
|--------------|-----------|-----------------------|----------|

DO NOT SCALE DRAWING

SHEET 3 OF 4

G89 J9K

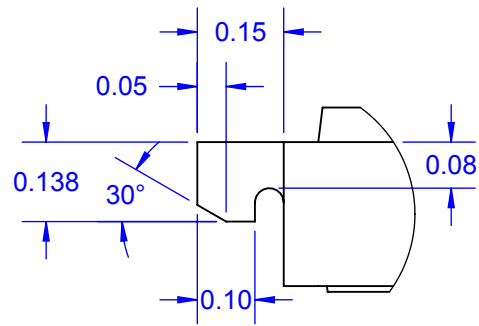
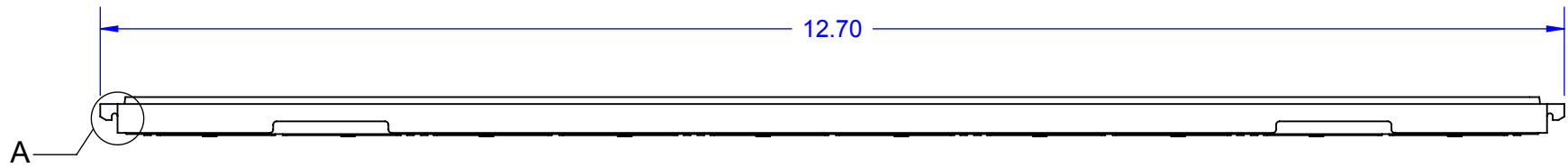

DETAIL A

98; 9 J9K

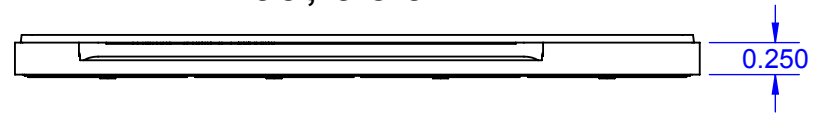

BUMPS
Ø0.12 x 0.020 HIGH

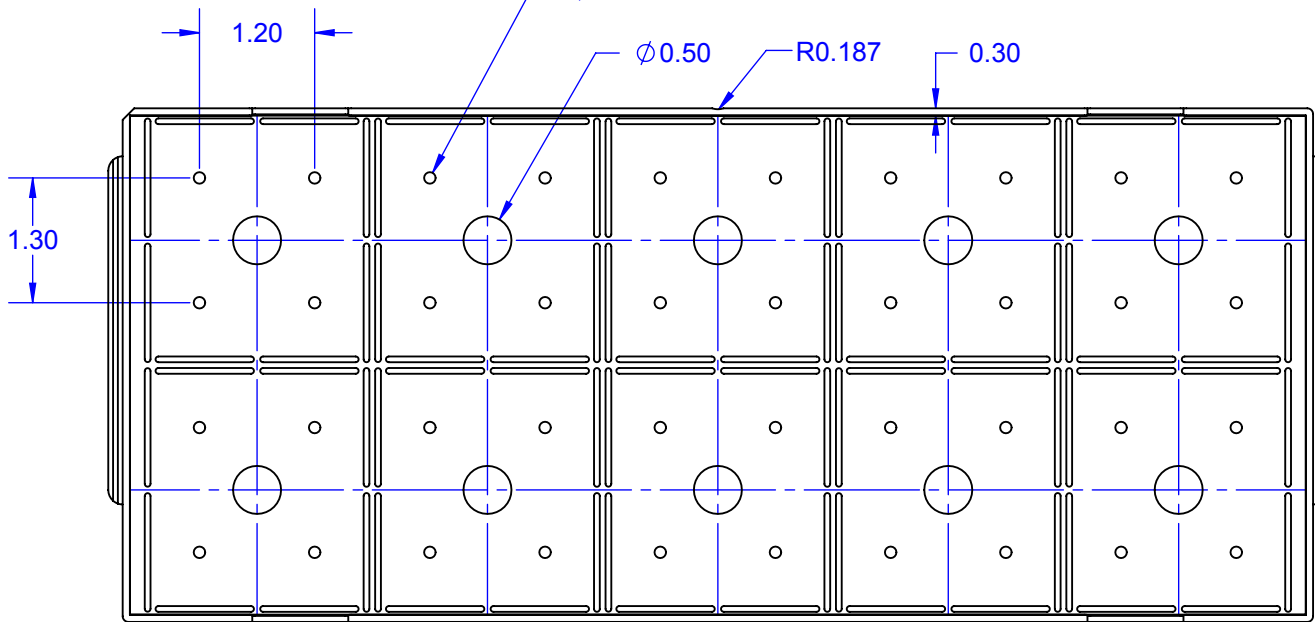

6 CHCA J9K

TopLine[®]

TITLE WP2-JIGTRAY-BLUE
JEDEC OUTLINE CARRIER

| | | | |
|--------------|-----------|-----------------------|----------|
| SCALE 2:3 | SIZE A | DRAWING NO. 782360 | REV A |
|--------------|-----------|-----------------------|----------|

DO NOT SCALE DRAWING

SHEET 4 OF 4