

### TOP VIEW

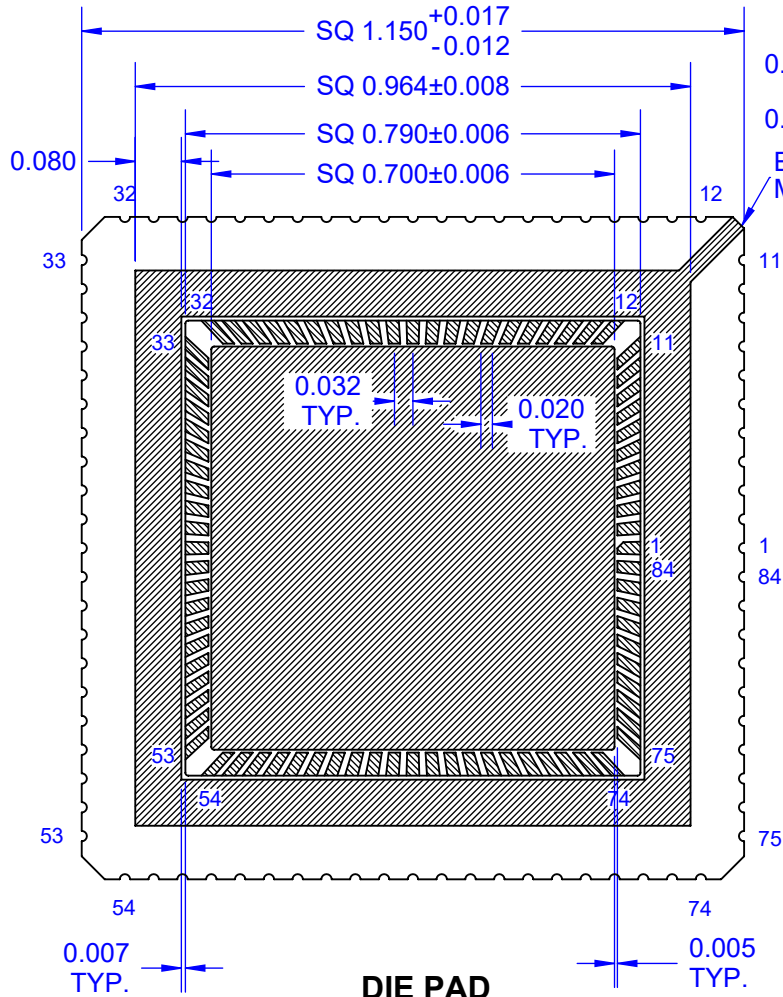

**DIE PAD**  
**0.700 x 0.700-inch**  
**[17.78 x 17.78mm]**

### SIDE VIEW

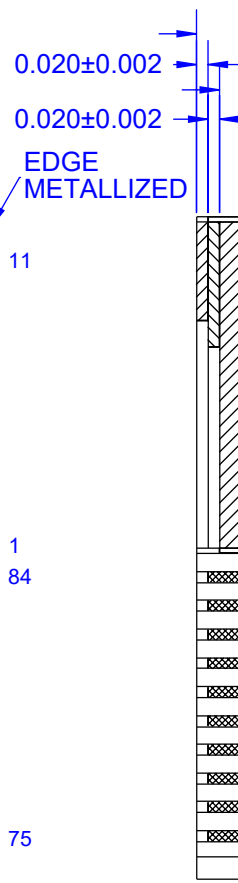

0.040x45°  
 3 PLACES

### BOTTOM VIEW

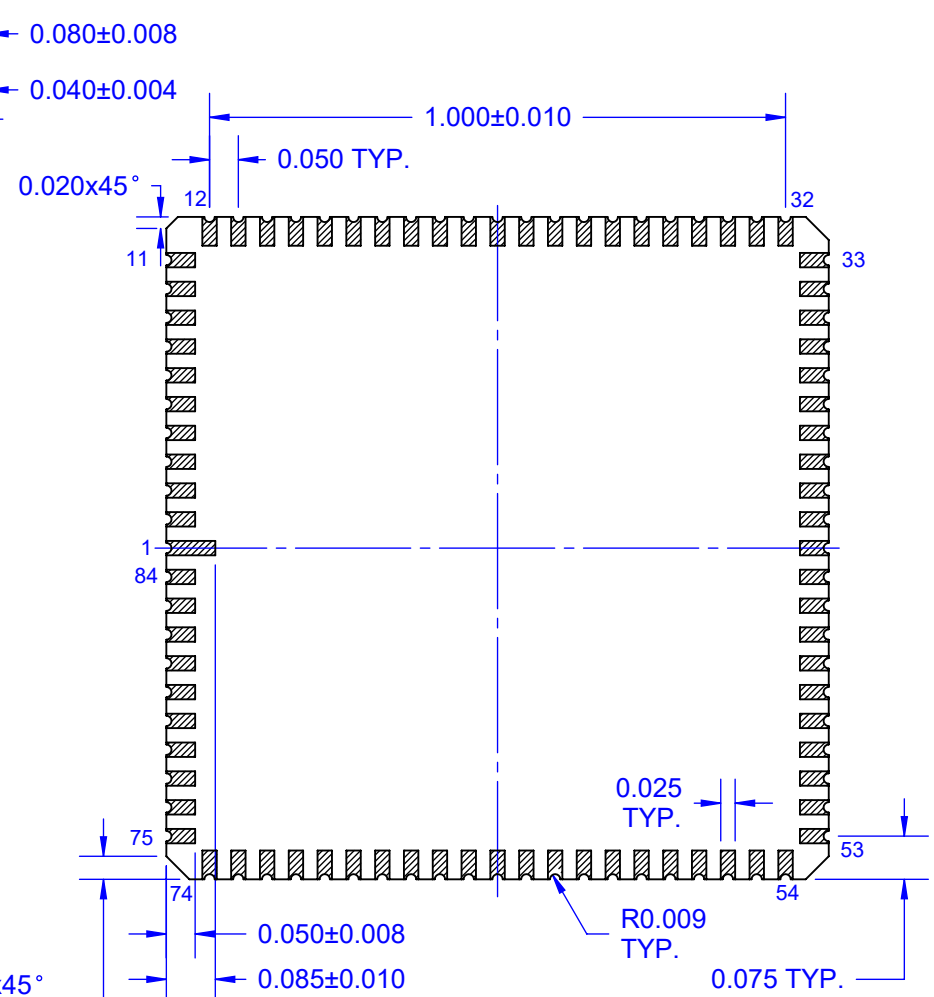

NOTES: (Unless Otherwise Specified).

1) DIMENSION in INCH.

2) PLATING:

Ni 80 Micro-inch (2.0um) MIN.

Au 60 Micro-inch (1.5um) MIN.

3) SEAL RING AND DIE ATTACH SHALL BE ISOLATED FROM ALL LEADS.

APPROVALS	DATE	<b>TopLine®</b>			
DRAWN T. Au	06/03/16				
ENG M. Hart	06/03/16	TITLE LCC84B50SQ.1.15-N700			
MFG		SCALE 10:1	SIZE A	DRAWING NO. 167247	REV A
QA					
CUST		DO NOT SCALE DRAWING			SHEET 1 OF 4
REVISED					

# BOND PAD DIAGRAM

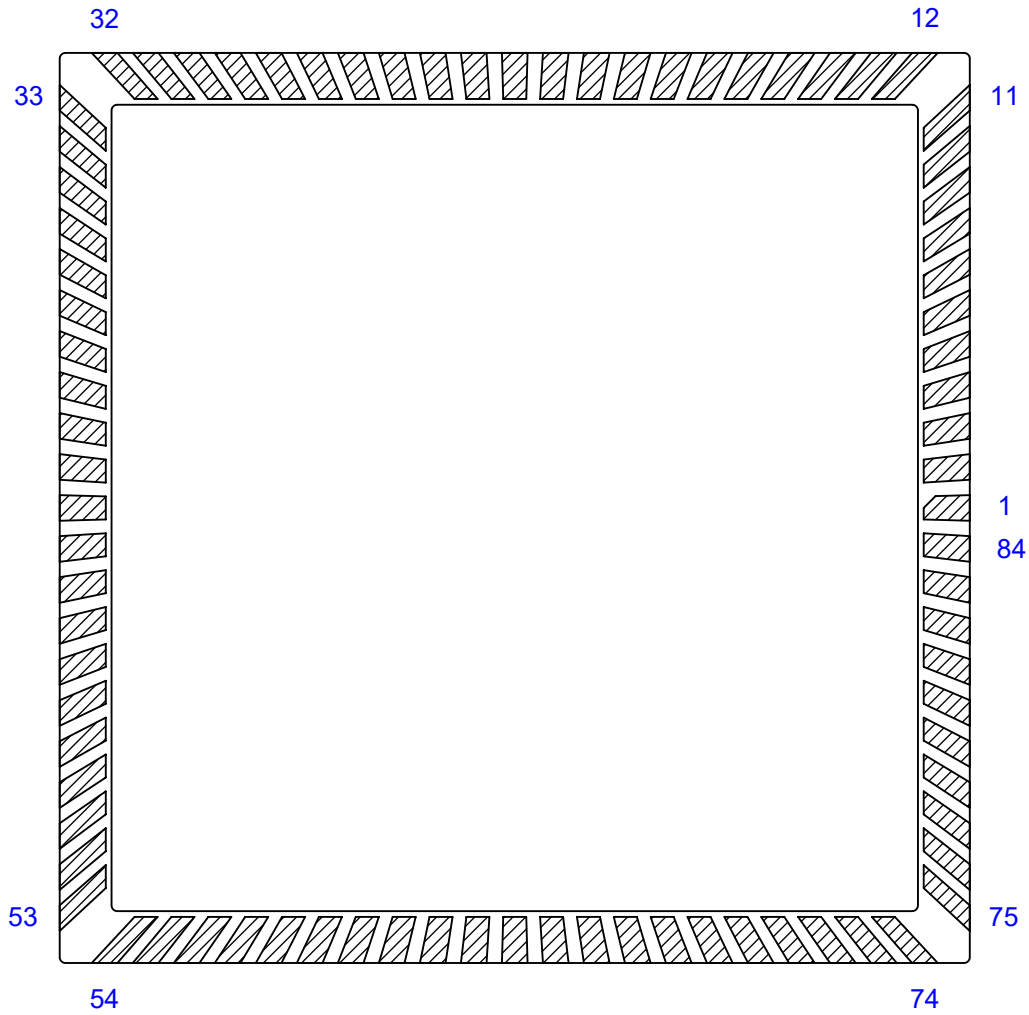

**TopLine®**

TITLE LCC84B50SQ.1.15-N700

SCALE 6:1	SIZE A	DRAWING NO. 167247	REV A
--------------	-----------	-----------------------	----------

DO NOT SCALE DRAWING

SHEET 2 OF 4

# MODEL

TOP  
CAVITY

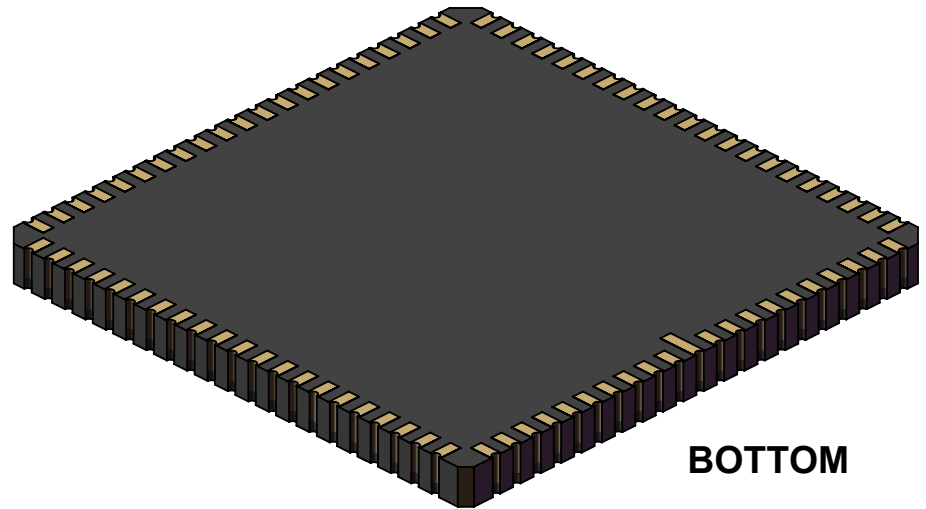
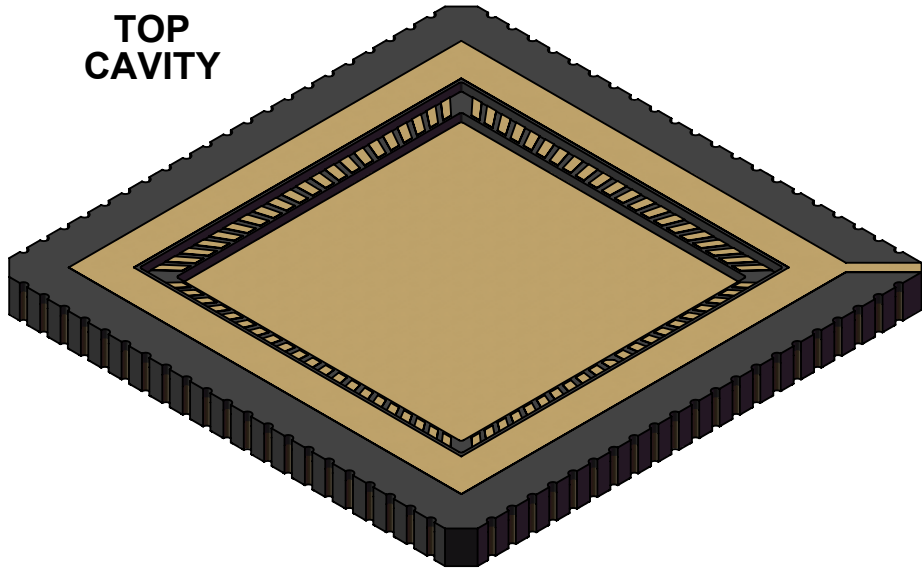

BOTTOM

**TopLine**<sup>®</sup>

TITLE LCC84B50SQ.1.15-N700

SCALE 3:1	SIZE A	DRAWING NO. 167247	REV A
--------------	-----------	-----------------------	----------

DO NOT SCALE DRAWING

SHEET 3 OF 4

# KOVAR LID

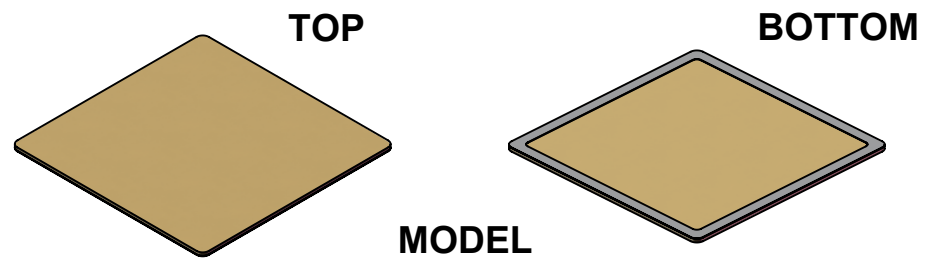
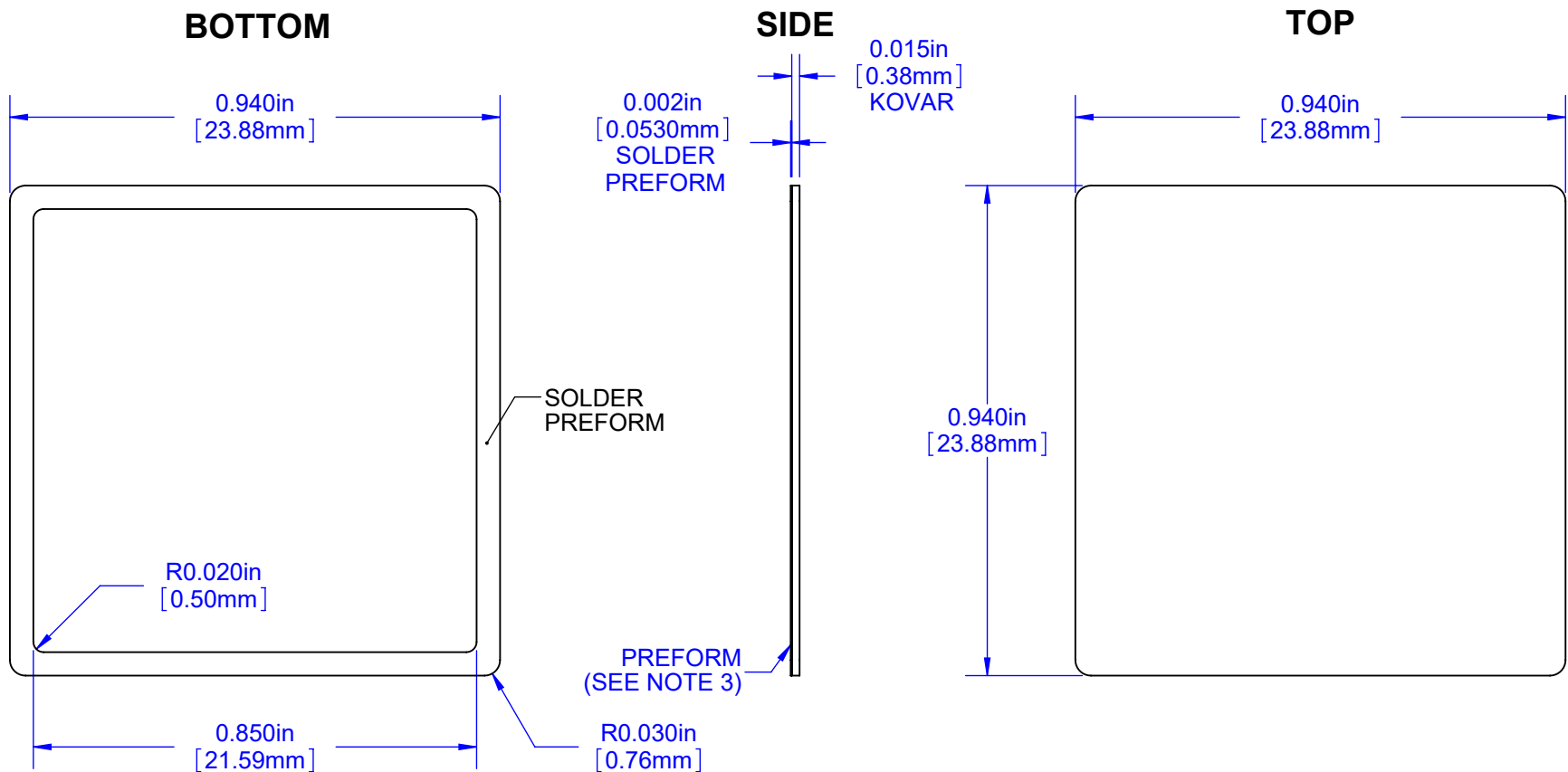

**NOTES:**

- 1) BASE MATERIAL: KOVAR or ALLOY 42.
- 2) PLATING: Ni 50~350 MICRO-INCH PER SIDE.  
Au 25 MICRO-INCH MIN PER SIDE.
- 3) SOLDER PREFORM: Au 80% ±1.0 Sn 20%.
- 4) FLATNESS 1.0 MIL (25µm) MAXIMUM PER 0.5-inch (12.7mm).

<b>TopLine®</b>			
TITLE		LC-940SQ-A COMBO LID	
SCALE	SIZE	DRAWING NO.	REV
3:1	A	170076	A
DO NOT SCALE DRAWING			SHEET 4 OF 4