

### BOTTOM VIEW

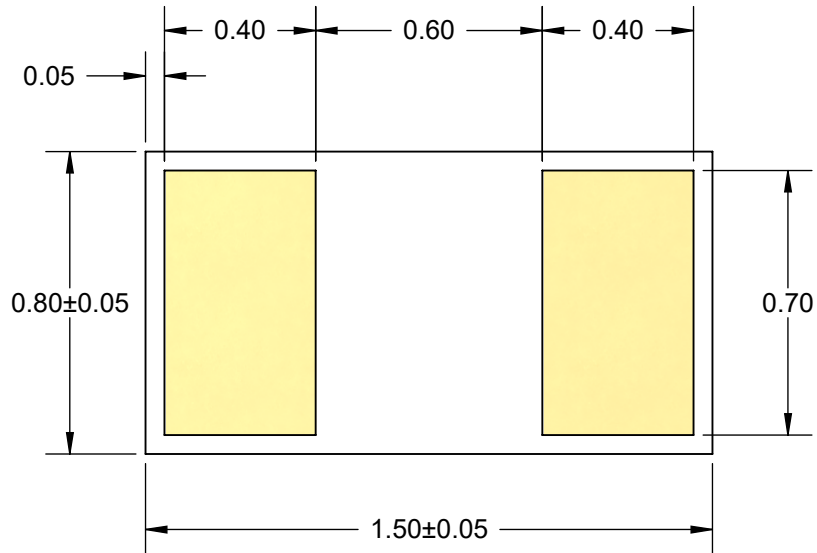

### PAD DETAIL A

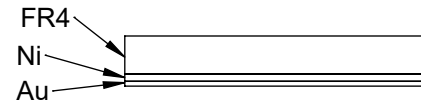

METALLIZATION THICKNESS	
Ni	4.0±1.5µm
Au	0.05±0.02µm

### SIDE VIEW

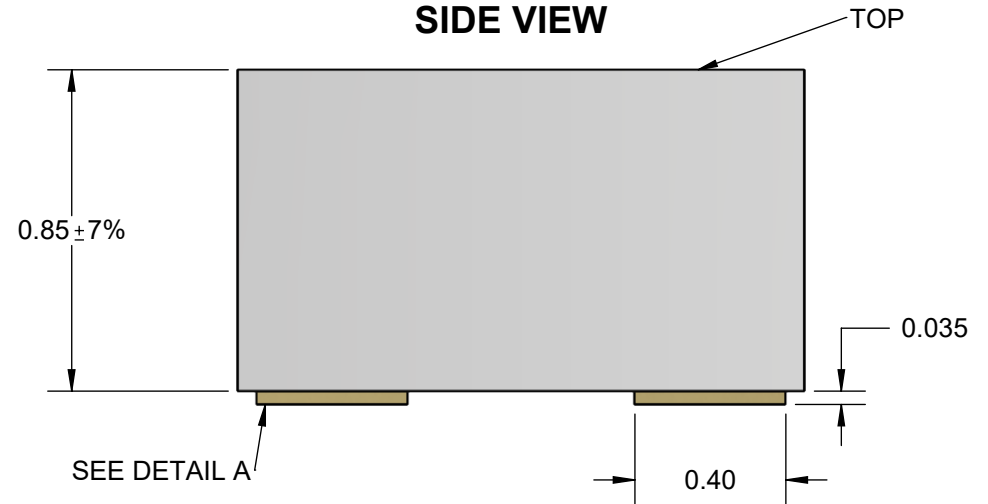

### RECOMMENDED PCB PATTERN

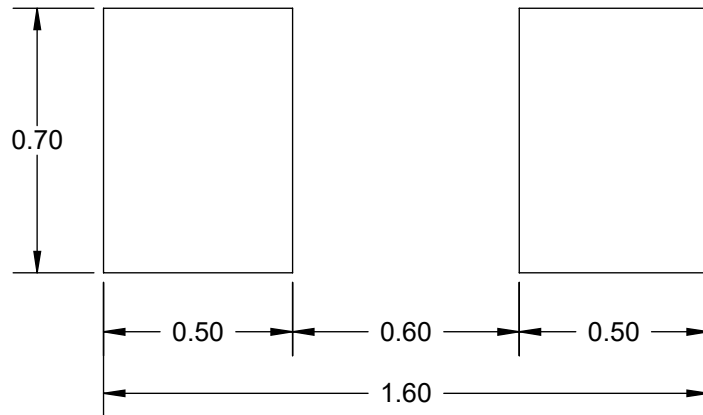

#### NOTES:

1. DIMENSION IN mm EXCEPT AS NOTED.
2. TERMINATION: NiAu.
3. Pb-FREE AND HALOGEN FREE.
4. COLOR WHITE
5. OPERATING TEMP: 280°C MAX

### MODEL

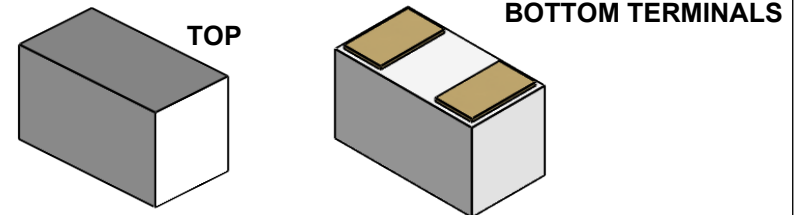

PCB DIMENSIONS ARE PRESENTED ONLY AS A GUIDELINE. DESIGNERS SHOULD USE THEIR OWN KNOWLEDGE BASE WHEN DESIGNING THE PCB.

APPROVALS	DATE				
DRAWN T.Au	11/3/2019				
ENG M. Hart	11/3/2019	SCALE	SIZE	DRAWING NO.	REV
MFG		50:1	A	060333	A
QA		DO NOT SCALE DRAWING			SHEET 1 OF 2
CUST					
REVISED					

# W8P4 CARRIER TAPE DIMENSION

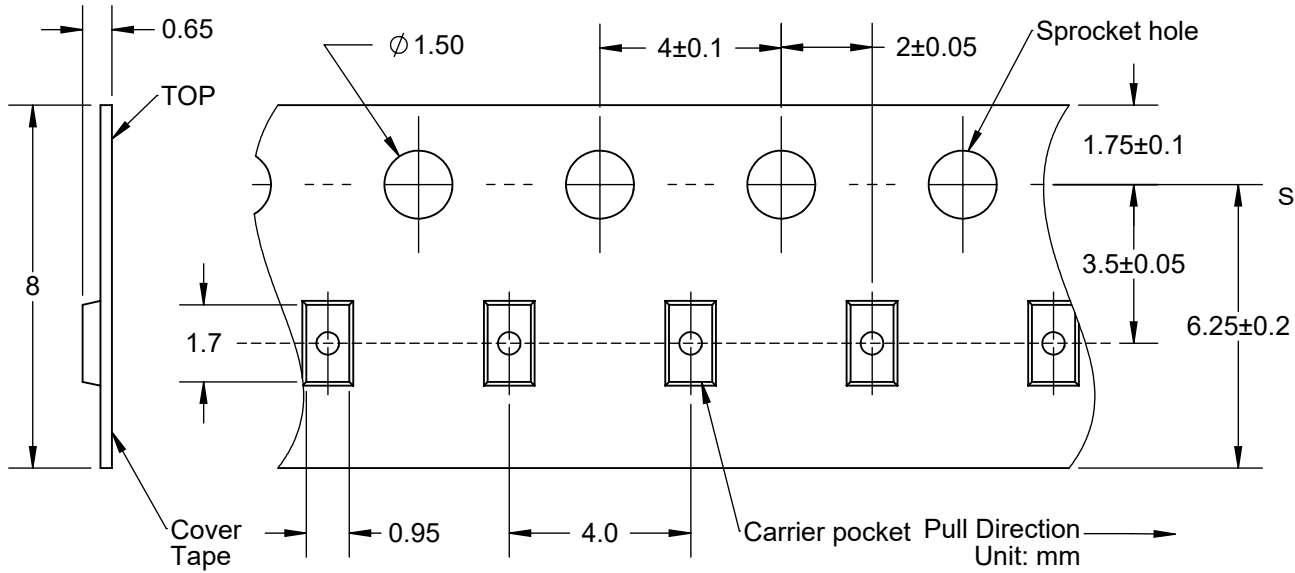

## PART NUMBER SYSTEM

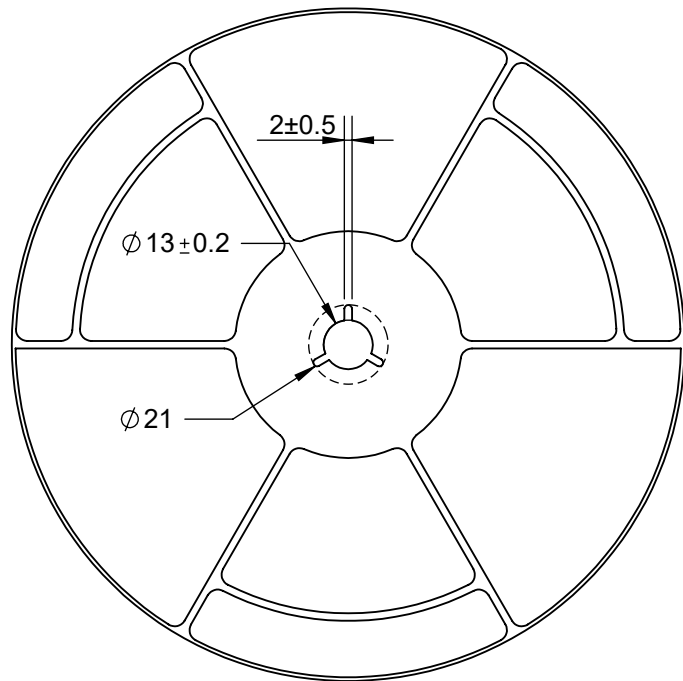
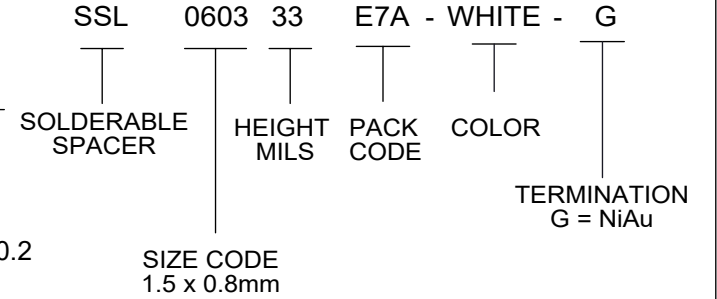

## REEL DIMENSIONS

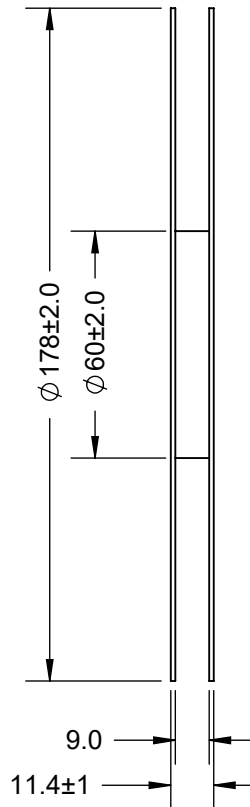

PACK CODE		
CODE	QTY	PACKAGE
E7A	3,000	REEL

NOTE: PLACE COMPONENT IN TAPE METAL SIDE DOWN

<b>TopLine®</b>			
TITLE SSL0603 - H 0.85mm BOTTOM TERMINAL SPACER			
SCALE NONE	SIZE A	DRAWING NO. 060333	REV A
DO NOT SCALE DRAWING			SHEET 2 OF 2