

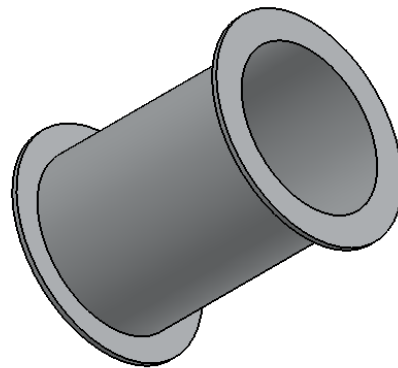

HALF INCH SPOOL FOR BONDING WIRE

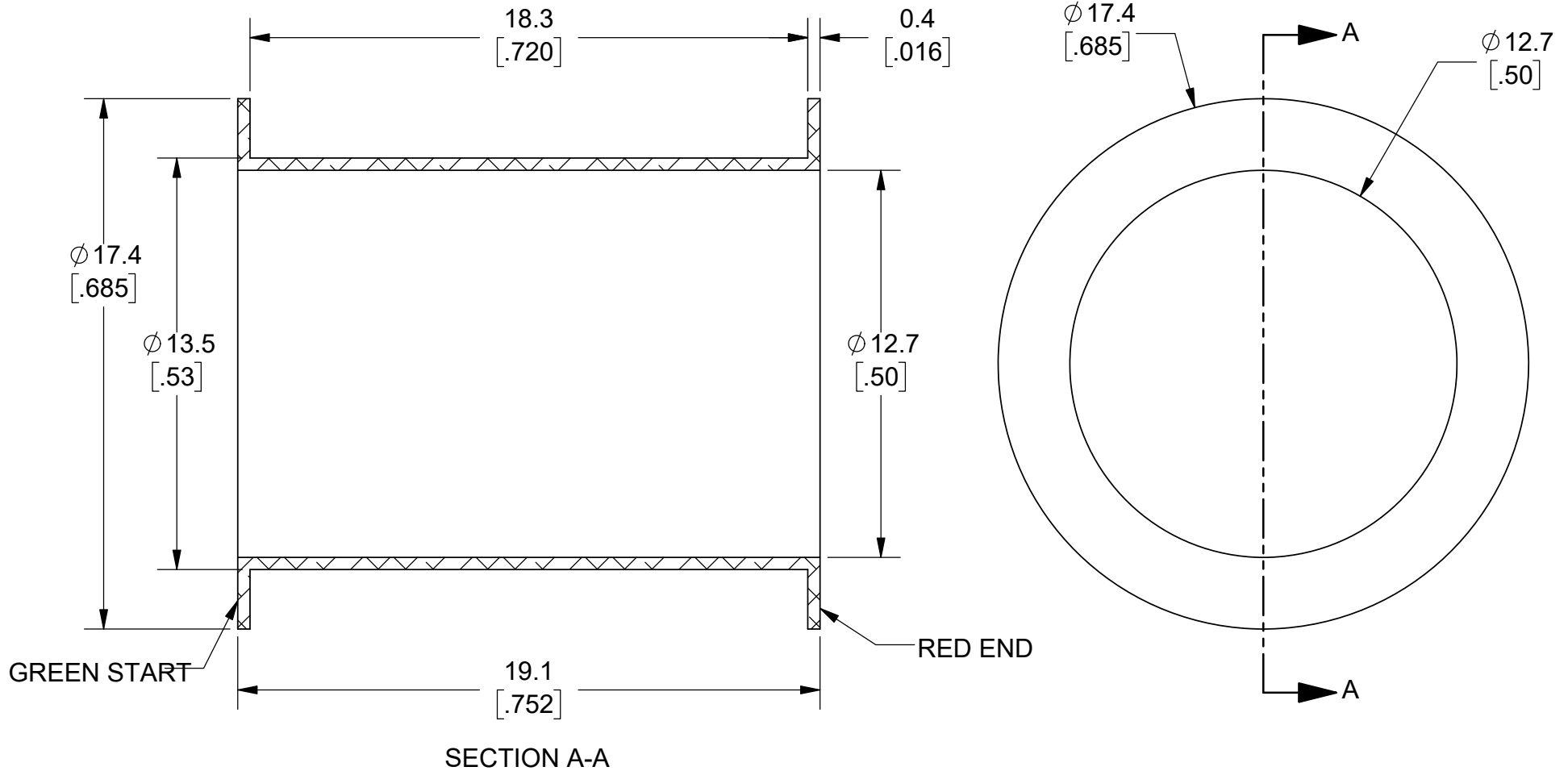

NOTES: (UNLESS OTHERWISE SPECIFIED).

- 1) DIMENSIONS: MM [INCH].
- 2) MATERIAL: ALUMINUM.
- 3) DEBURR (BREAK ALL EDGES).
- 4) FINISH: MATTE, ANODIZED.
- 5) SPOOL DIMENSIONS PER ASTM F72/B.

APPROVALS		DATE				
DRAWN	J. Hines	12/29/2016				
ENG	M. Hart	12/29/2016			AL-1/2	
MFG			SCALE	SIZE	DRAWING NO.	REV
QA			5:1	A	400106	A
CUST			DO NOT SCALE DRAWING			SHEET 1 OF 1
REVISED						